

SERVICE MANUAL



BENEFON SPICA TDP-60-HN

TDP-60-HN

1.0 GENERAL	1 - 1
1.1 TECHNICAL INFORMATION	1 - 1
1.1.1 Operational System	1 - 1
1.1.2 Dimensions	1 - 1
1.1.3 Power Consumption	1 - 1
1.1.4 Accessories	1 - 1
1.1.5 Alert Functions	1 - 2
1.1.6 Memory	1 - 2
1.1.7 Clock	1 - 2
1.1.8 Auto Answer; Pager/Hands Free	1 - 3
1.1.9 Other Functions	1 - 3
1.1.10 Additional Exchange-Based Features	1 - 4
1.1.11 Manufacturer	1 - 4
1.2 PRODUCT FAMILY	1 - 5
2.0 OWNER'S MANUAL	2 - 1
3.0 INSTALLATION INSTRUCTIONS	3 - 1
3.1 Phone Programming	3 - 1
3.1.1 To program Using the Phone Keys	3 - 1
3.1.2 To program Using the BeneLoc Program	3 - 3
3.2 CAR KIT	3 - 5
3.2.1 Antenna	3 - 5
3.2.2 Phone Holder KDS-60	3 - 5
3.2.3 Microphone	3 - 5
3.2.4 Cable	3 - 5
3.2.5 External Handset HDS-50	3 - 6
3.2.6 Car Box UDH-60	3 - 6
3.2.7 Hf Speaker	3 - 6
3.2.8 BENEBOOST KIT	3 - 8
3.3 HF-FUNCTION	3 - 10
3.3.1 CAR KIT TUNING (theory)	3 - 10
3.3.2 CAR KIT SWING (theory)	3 - 12

3.3.3 HF-function tuning in practice	3 - 13
4.0 SERVICE APPLICATIONS	4 - 1
4.1 BeneWin SCA-60	4 - 1
4.1.1 Installation of BeneWin program	4 - 1
4.1.2 To start the BeneWin program	4 - 4
4.2 BeneLoc	4 - 5
4.2.1 Installation of BeneLoc program	4 - 5
4.2.2 To start the BeneLoc program	4 - 6
4.2.3 Using the BeneLoc program	4 - 7
5.0 PHONE'S CONSTRUCTION	5 - 1
5.1 LOGIC / AUDIO	5 - 2
5.1.1 General	5 - 2
5.1.2 Connectors:	5 - 3
5.1.3 Functions	5 - 5
5.1.4 Function Description	5 - 9
5.1.5 TX-audio	5 - 9
5.1.6 RX-Audio	5 - 10
5.1.7 FII Signal	5 - 10
5.1.8 FFSK Modem	5 - 10
5.1.9 The DTMF Generator/Receiver	5 - 11
5.1.10 Signal level detectors	5 - 11
5.1.11 Compander/Expander	5 - 11
5.1.12 Alarm buzzer	5 - 11
5.1.13 The other in audio asic (I401)	5 - 12
5.1.14 Parts list OA1900	5 - 13
5.2 RF MODULE	5 - 28
5.2.1 General	5 - 28
5.2.2 Functional Description	5 - 28
5.2.3 Control- and Output-Signals	5 - 28
5.2.4 General	5 - 29
5.2.5 Function Description	5 - 29
5.2.6 Control- and Output-Signals	5 - 30
5.2.7 General	5 - 31
5.2.8 Input- and Output-Signals	5 - 32

5.2.9 General	5 - 33
5.2.10 Function Description	5 - 33
5.2.11 Control- and Output-Signals	5 - 33
5.2.12 Parts list OY1920	5 - 36
6.0 CAR ASSEMBLY KIT	6 - 1
6.1 CARBOX UDH-60	6 - 2
6.1.1 Including attached functions	6 - 2
6.1.2 Connector descriptions	6 - 2
6.1.3 Parts list OW1951	6 - 5
6.2 EXTERNAL HANDSET WITH CRADLE HDS-50 ...	6 - 19
6.2.1 External Handset (not serviceable)	6 - 19
6.2.2 General	6 - 20
6.2.3 Connector XIN Signals	6 - 21
6.2.4 Microphone	6 - 21
6.2.5 Speaker	6 - 21
6.2.6 Hook	6 - 21
6.2.7 Parts list OO0009	6 - 22
6.2.8 Cradle	6 - 26
7.0 BENEBOOST	7 - 1
7.0.1 TECHNICAL INFORMATION	7 - 2
7.1 Functional description	7 - 2
7.1.1 Transmitting section and power control	7 - 2
7.1.2 Front end amplifier	7 - 3
7.1.3 DC power and control logic	7 - 3
7.1.4 Testpoint levels	7 - 3
7.1.5 Part lists OC1910	7 - 4
8.0 OTHER ACCESSORIES	8 - 1
8.1 PORTABLE HANDS FREE KIT EHD-60	8 - 2
8.1.1 SPECIFICATION FOR HEADSET ADAPTER OO0313	8 - 2
8.1.2 Connector descriptions	8 - 2
8.1.3 Operation	8 - 3
8.1.4 Parts list OO0313	8 - 4

1.0 GENERAL

General

1.1 TECHNICAL INFORMATION

1.1.1 Operational System

NMT-450i

1.1.2 Dimensions

Size: 56 x 145 x 23 mm

Weight: 240 g

Volume: 159 cm³

1.1.3 Power Consumption

- Batteries: 4x 1.2 V NiMH
- Sleep current: 2 mA
- Standby current: 43 mA
- Conversation mode, high power: app. 0.9 A
- Conversation mode, low power: app. 0.4 A

Charger:

- automatic 1 h rapid charging for NiMH batteries

1.1.4 Accessories

- hands free car kit (carbox, holder, car-radio mute, microphone, loudspeaker, external alert)
- BeneBoost car amplifier
- light holder
- portable hands free
- line interface
- mains charger
- cigarette lighter charger
- desktop charger
- external handset with holder

- external antenna adapter
- BeneWin
- hand strap
- belt clip

1.1.5 Alert Functions

Adjustable ringing tones

- type, 9 fixed, one changeable with BeneWin
- volume
- progressive or fixed

Silent alert

- short tone and 'call is coming' text in the display

Vibrating alert

- vibrator in optional batteries

1.1.6 Memory

Alphanumeric

- 99 memory locations, 23 characters, 16 alphanumeric / memory location
- memory scroll and recall in alphabetical or numerical order
- writing in memory during a call

Repeat: last dialled number or one of 6 numbers from the quick-memory locations

1.1.7 Clock

- time and date display
- real time alarm setting
- real time power on setting
- real time power off setting
- elapsed conversation time counter (both incoming and outgoing)
- received call counter and time display

1.1.8 Auto Answer; Pager/Hands Free

- pre-set number of ring tones before answering (0...6)

Pager

- answers incoming calls and receives numeric messages
- 9 memory locations (23 characters / location)

Hands Free

- answers incoming calls when connected to HF

1.1.9 Other Functions

DTMF - receiver / transmitter

DTMF - key tones

Display and key illumination

Volume control

- 5 levels
- level indicator

Battery charge level indicator

- battery empty alarm tone and display
- used battery capacity display
- battery specific charge memory

Field strength indicator

Battery-saving function

Menu structure for user customisation

Prefix editor

Keys lockable to prevent accidental operation

Phone code to prevent unauthorised use

SIS protection function

CLIP, calling line identity presentation

'+' international prefix

1.1.10 Additional Exchange-Based Features

Call management

- New call
- Pick incoming call
- Select call

MFT-function (DTMF signal transmission)

1.1.11 Manufacturer

Benefon Oyj

P.O. Box 84

24101 Salo

Finland

Tel. +358 2 77400 Fax. +358 2 7332633

1.2 PRODUCT FAMILY

- **BENEFON SPICA HANDPORTABLE TDP-60-HN**
- **MAINS CHARGER CMA-60-230**
- **CIGARETTE LIGHTER CHARGER CCS 60-12**
- **DESKTOP CHARGER CTA-60**
- **LIGHT HOLDER KDC-60**
- **PORTABLE HANDS FREE EHD-60**
- **HANDS FREE CAR KIT**

This kit includes a charging holder KDS-60, carbox UDH-60, loudspeaker and microphone for hands free function, car radio mute and external alert facility.

- **EXTERNAL HANDSET WITH HOLDER HDS-50**

This is an optional accessory for the hands free car kit.

- **BENEBOOST CAR AMPLIFIER TDB-60-x**

This is an optional accessory for the hands free car kit.

- **LINE INTERFACE LIF-60**

To connect to the mobile phone any appliance using DTMF or MFT dialling such as the home telephone, wireless phone, answering machine, telefax or modem and microcomputer.

- **BENEWIN SCA-60**
- **ANTENNA ADAPTER RAC-60**
- **HAND STRAP**
- **BELT CLIP**

Benefon Spica And The Chargers

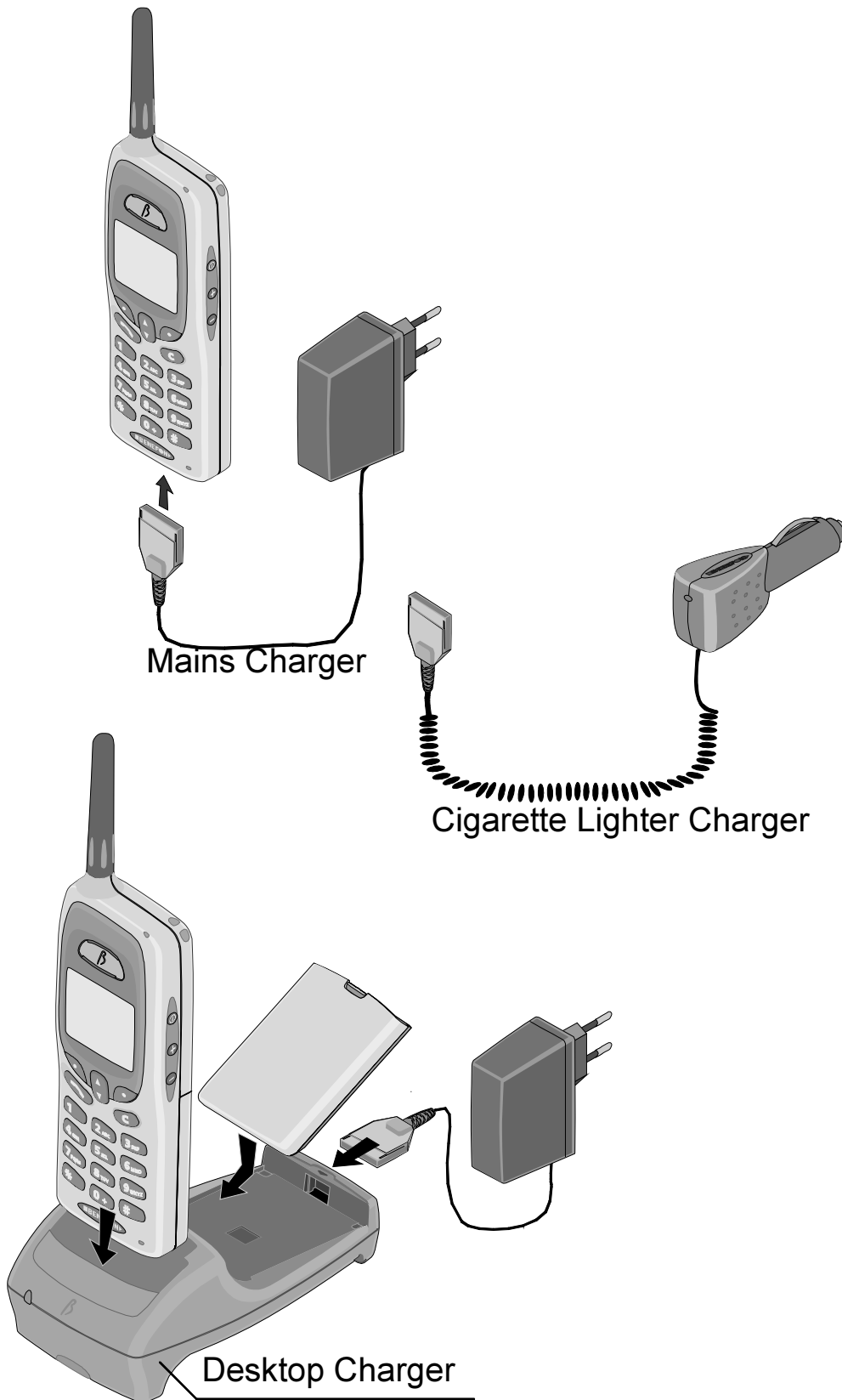

Light Car Installation

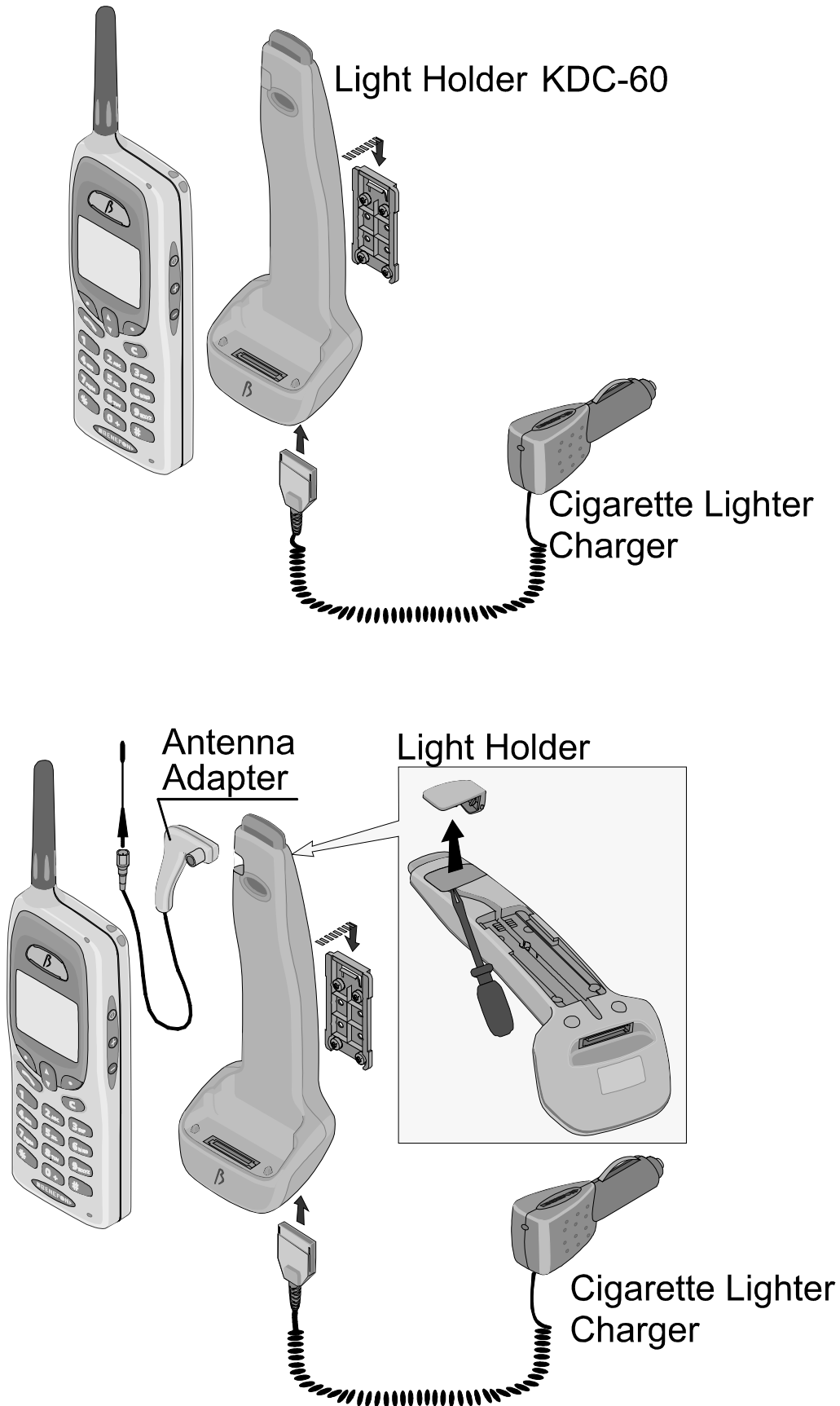

Car Installation

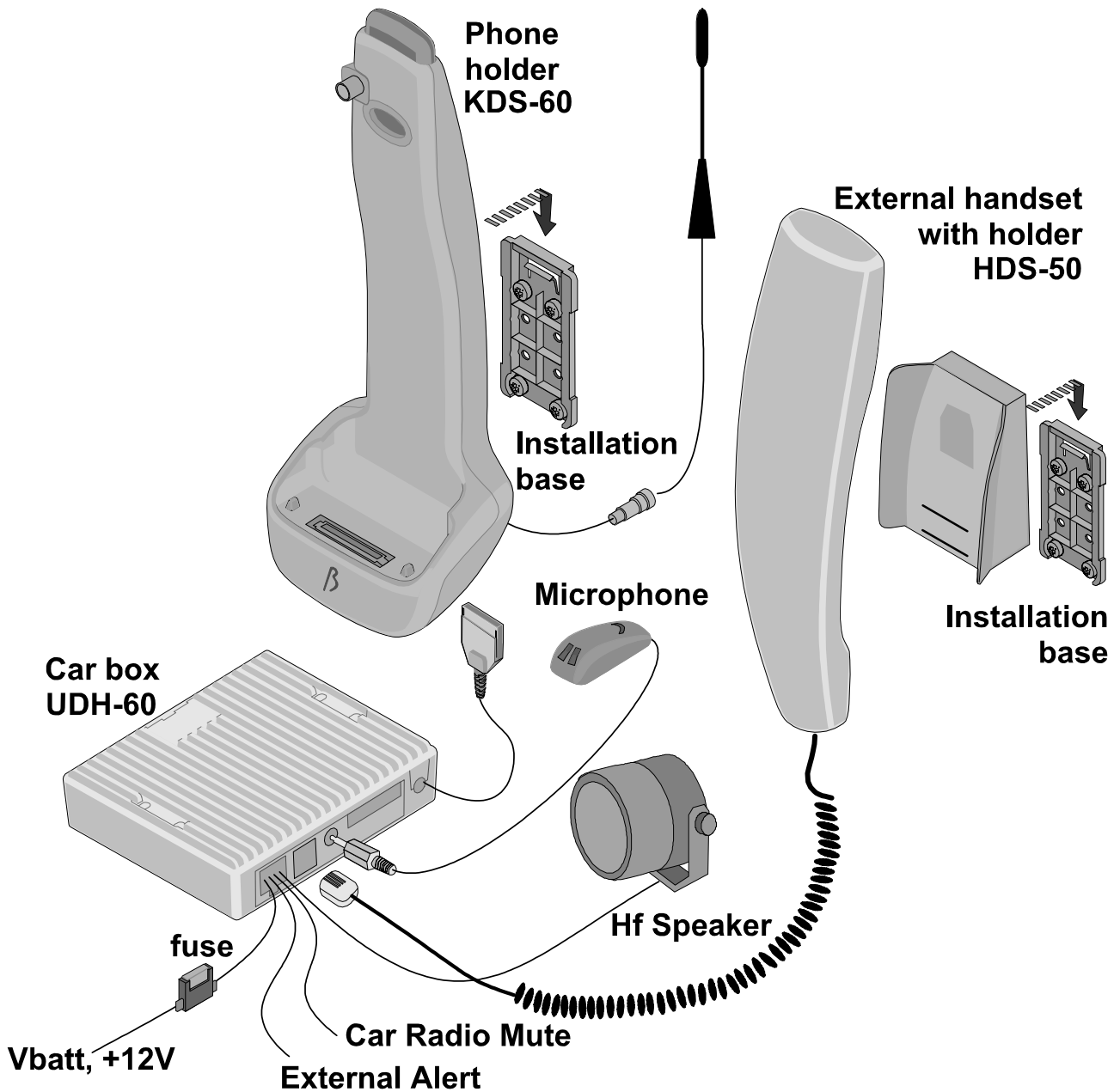

Car Installation with BeneBoost

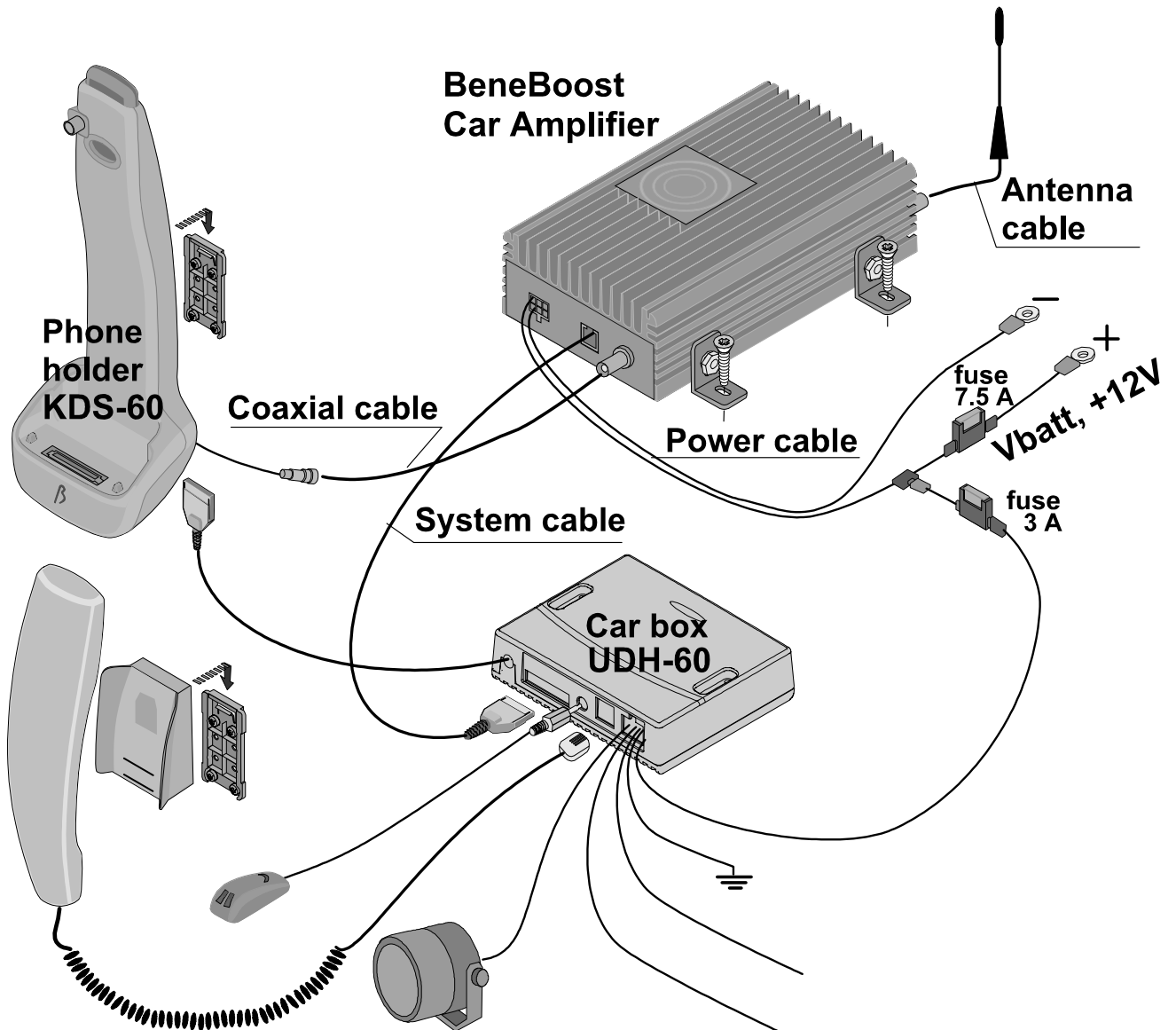

Other Accessories

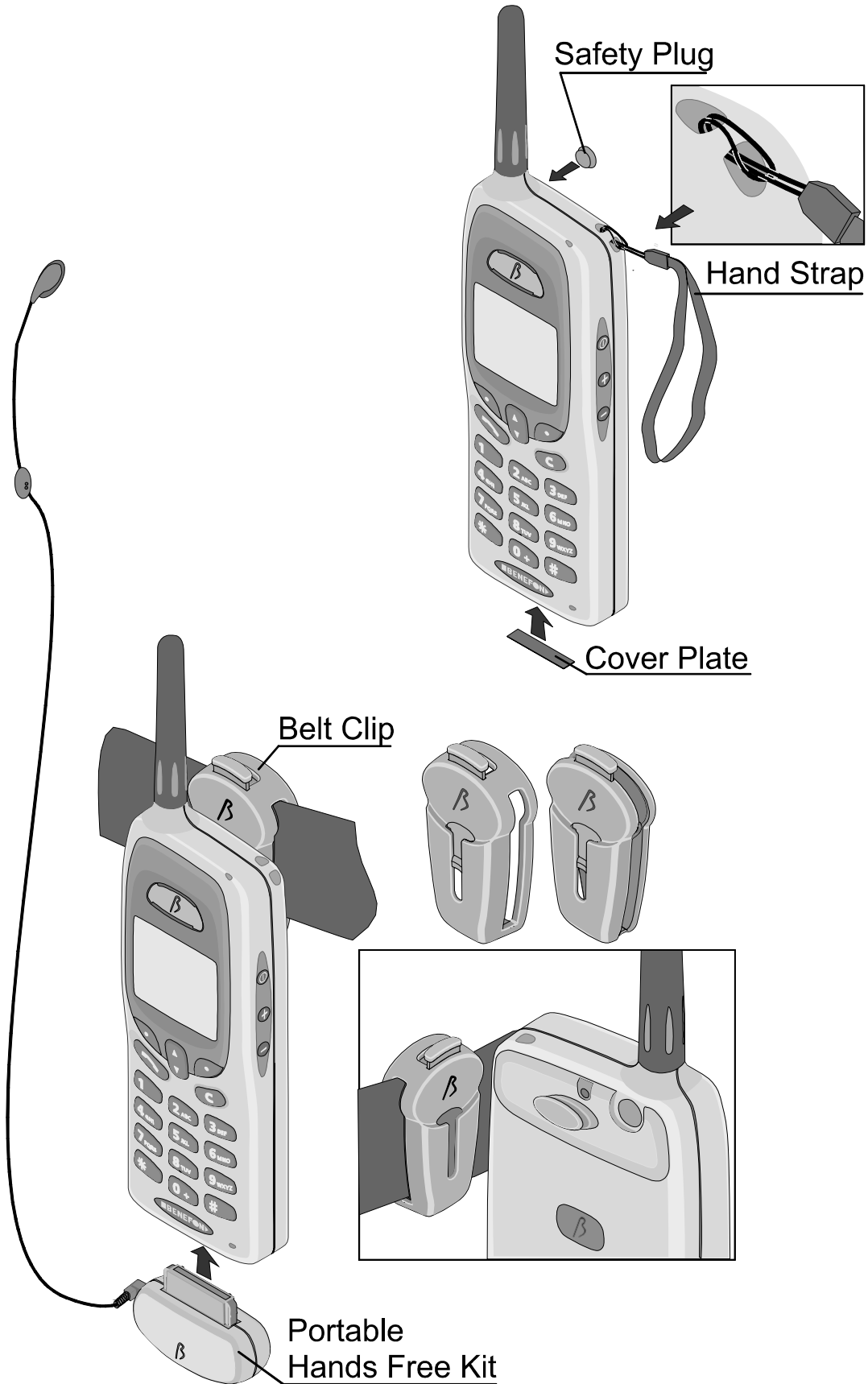

BeneWin

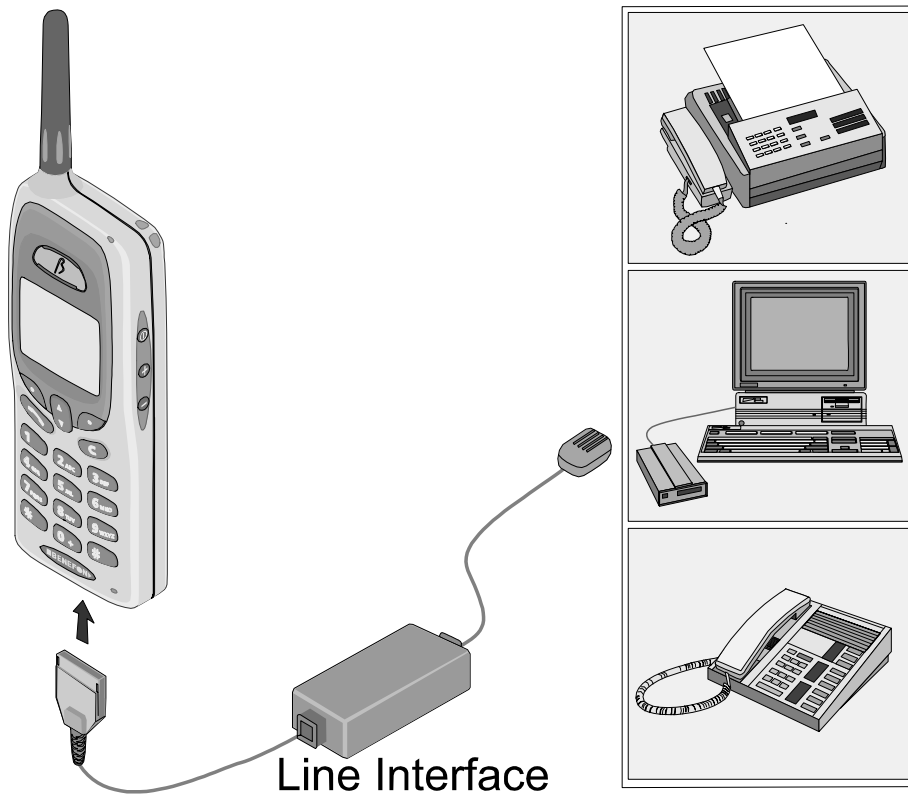
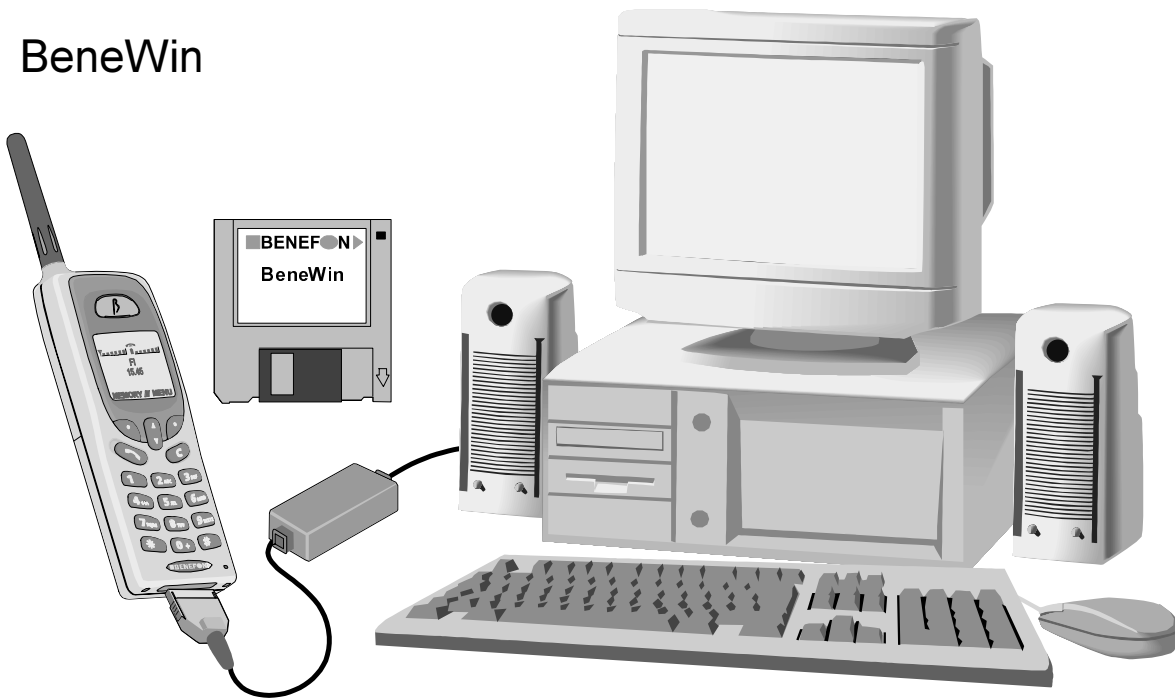



2.0 OWNER'S MANUAL

3.0 INSTALLATION INSTRUCTIONS

Installation Instructions



3.1 Phone Programming

You can program Benefon Spica by using either the keys on your phone, or the BeneLoc computer program. In either case, you will need a localbox.





Programming Menu Commands:

- SALES DATE
- RADIO PATH ID
- PHONE CODE
- HF-FUNCTION
 - CAR KIT TUNING (background noise tuning)
 - CAR KIT SWING (MIC-ERP contrast tuning)
- SW VERSION
- SAK
- PRODUCT CODE
- UPDATE LOCALBOX
- INTERLEAVING
- AUTOMATIC ROAMING
- RESET RAM

3.1.1 To program Using the Phone Keys

1. Connect the localbox to your phone, and turn the phone on.
2. Press  and the following text will appear in the display: *****BENEFON*****.  will be flashing in the display.

3.1.1.1 Sales Date

1. Choose  **SELECT**. The following text will appear in the display: **SALES DATE [XXXXXX]**.
2. Choose  **CHANGE**. [XXXXXX] will be replaced by the date **[daydaymonthmonthyearyear]**. Remember to check that the date is correct. If the date is correct, choose  **SAVE**. If the date is incorrect, delete it by choosing  and enter the correct date (six digits in the following form: daydaymonthmonthyearyear). To save the date, choose  **SAVE**.

It is possible to program the sales date **ONLY ONCE**, which means that you will not be able to change it again afterwards. If the sales date has not been programmed, your phone will not enter the normal stand-by mode.

3.1.1.2 Radio Path Identification

1. Press **▼**, and the following text will appear in the display:
RADIO PATH ID [XXXXXXXXXX].
2. Choose **▶ CHANGE**. Enter the radio path identification (ten digits), and save the identification by choosing **▶ SAVE**. Remember to check that the radio path identification is correct.

3.1.1.3 Phone Code

1. Press **▼** **▼**, and the following text will appear in the display:
PHONE CODE [XXXX].
2. Choose **▶ CHANGE**. Enter the phone code (four digits), and save the code by choosing **▶ SAVE**.

3.1.1.4 Automatic roaming and Interleaving

The Dealer activates or deactivates them according to the operator's or the customer's likings.

3.1.1.5 Closing Instructions

1. Having programmed the necessary information choose **▶ QUIT**, and the following text will appear in the display: *****BENEFON*****.
2. Turn off your phone, and disconnect the localbox.
3. Turn the phone on once more, and make a test call.

3.1.2 To program Using the BeneLoc Program

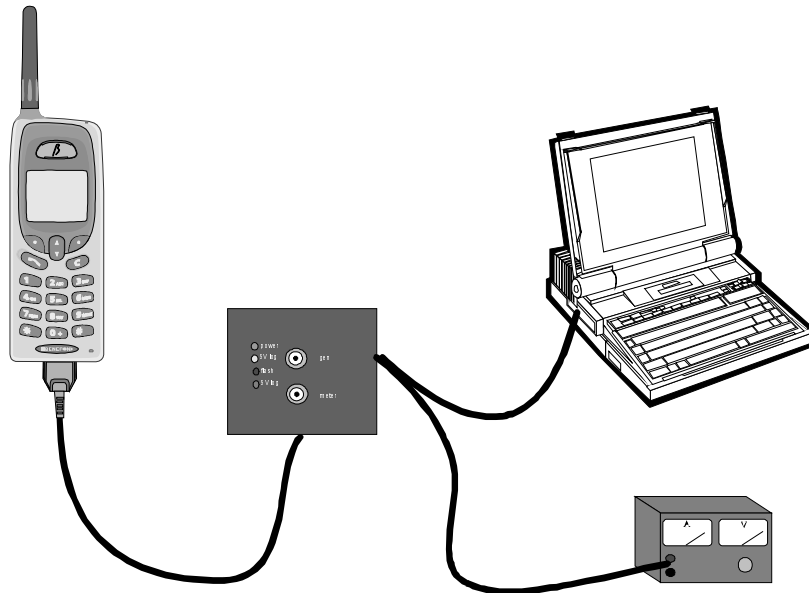

Start the installed program by clicking the icon. The phone must be connected to the system as described above.

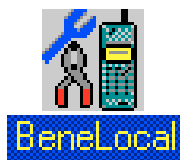

Main window

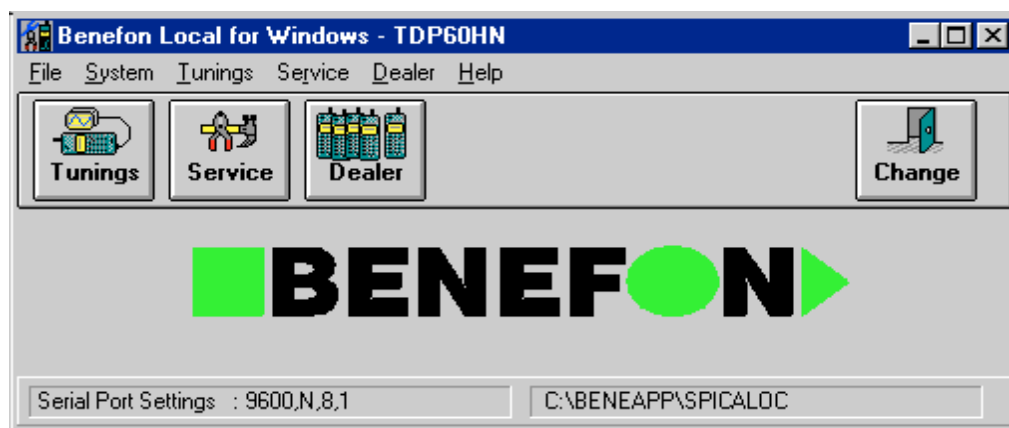

Press Dealer-key to enter the programming window.

The screenshot shows a window titled "NMT450" with a blue title bar. The main area is divided into two columns under the heading "Phone data:". The left column is titled "Miscellaneous:" and contains four input fields: "Identity" with the value "0123456789", "Sales date" with "010198", "Phone Code" with "1234", and "Interleaving" with a checked checkbox. Below these is "Autoroaming" with an unchecked checkbox. The right column is titled "Sis info" and contains four yellow-highlighted input fields: "MANUFACTURER:" with "31", "DATE (dd/mm/yy):" with "21/5/97", "SERIAL NUMBER:" with "13508", and "CHECKSUM:" with "225". Below the "Phone data:" section is a "Log info" label followed by a text input field. At the bottom of the window are four buttons: "Read phone", "Program phone", "Log", and "Exit".

You can read the phone data by pressing the **Read phone** -key. You can change the miscellaneous settings with the computer and transfer them to phone by pressing the **Program phone** -key.

BeneLoc includes **Help**-program for further information.

3.2 CAR KIT

The Car Kit includes a phone holder (KDS-60), a car box (UDH-60), an antenna, an installation base, a hf speaker, a microphone and a cable. The Car Kit sales package also includes an installation materials bag, which contains the necessary installation equipment. On the next page you will find a diagram of connections explaining how to install the Car Kit.

Caution:

The Car Kit should only be installed by Benefon authorized installer. The end user should never attempt to install the Car Kit without professional assistance. Professional installers have the required tools and knowledge for installing the Car Kit properly and safely. The terms of warranty also require that the Car Kit is installed by professionally trained personnel. Cable routing may cause interference with the components of the vehicle's electronic systems (such as ignition and braking systems). It is recommended that cables not be routed next to such electronic components.

3.2.1 Antenna

Choose a suitable place for the antenna. It is recommended that you place the antenna on the roof of the vehicle.

3.2.2 Phone Holder KDS-60

Choose such a place for the phone holder in the vehicle that will be both easy and safe when using the phone. Remember to leave enough space for the antenna plug behind the phone holder. First, fix the installation base to the place you have chosen, and then install the phone holder in the installation base.

3.2.3 Microphone

Install the microphone so that it is aimed directly at the user, and comes as close as possible to the user's mouth. A good place for the microphone is near the rearview mirror where the noise level is lower than, for example, beside a windshield pillar. It is also possible to install the microphone on a sun visor, but then it will be inconvenient to use the sun visor and microphone at the same time. One alternative would be a swan-neck microphone as it can be placed closest to the user's mouth.

3.2.4 Cable

Obtain the necessary (+)-electrical current from a suitable place, preferably directly from the battery of the vehicle. Connect the fuse chamber to the (+)-wire. You will find the fuse chamber in the installation materials bag. Connect

the ground lead to the frame of the car with a short wire.

3.2.5 External Handset HDS-50

Install the external handset the same way as you installed the phone holder.

3.2.6 Car Box UDH-60

Place the car box out of sight inside the dashboard of the car or to another suitable place. First, connect the wires to the car box. Install the car box so that the heat sink has some space for cooling. The car box has holes which enable you to fasten the car box with a cable tie. The installation materials bag also contains adhesive band fasteners.

3.2.7 Hf Speaker

Install the speaker in a suitable place near the floor of the car. To avoid echo remember to pay attention to the position of the microphone as well.

A Diagram of Connections

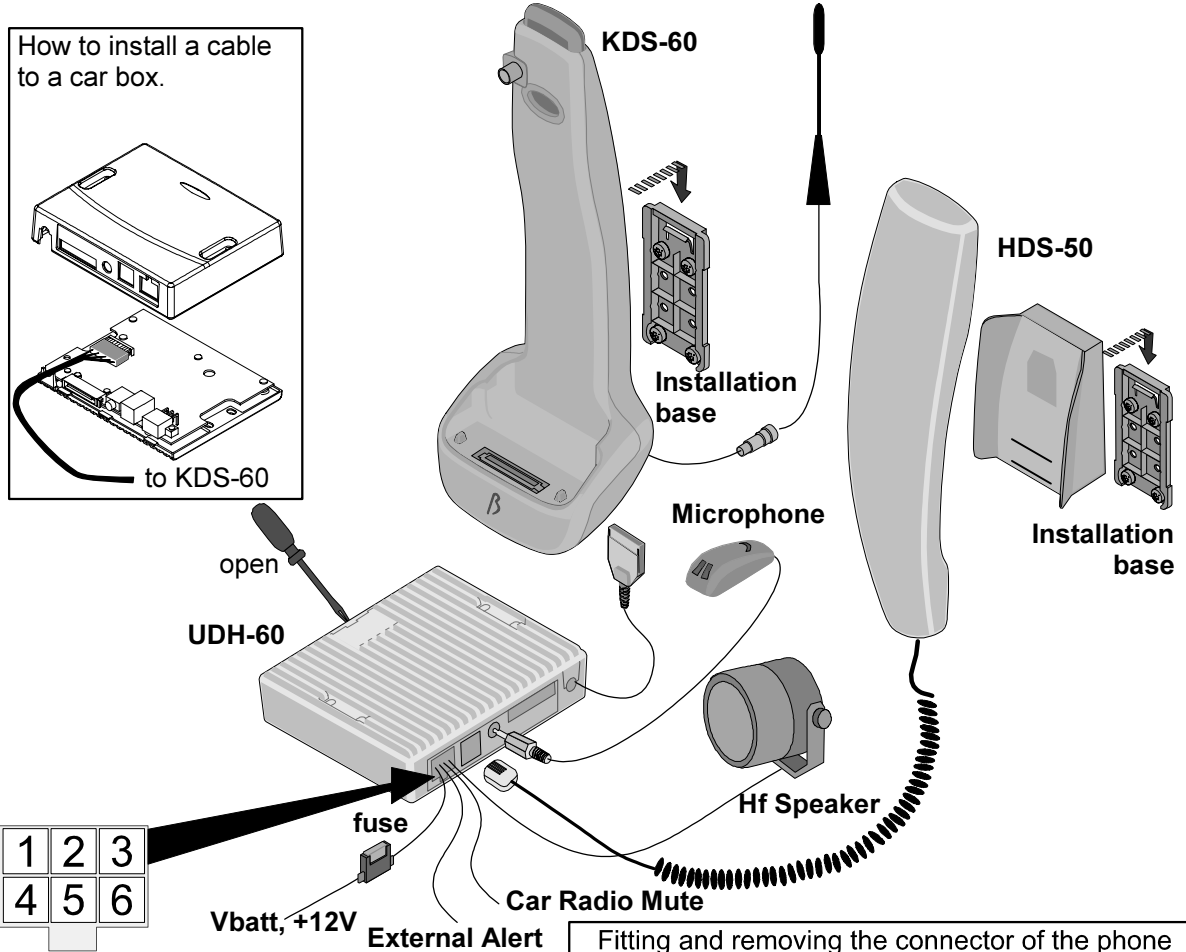

PIN	Name	Colour
1	Car Radio Mute (active low)	Blue
2	Hf Speaker	Grey
3	Ground	Black
4	External Alert (active low)	Brown
5	Hf Speaker	Grey
6	Vbatt, +12 V	Red

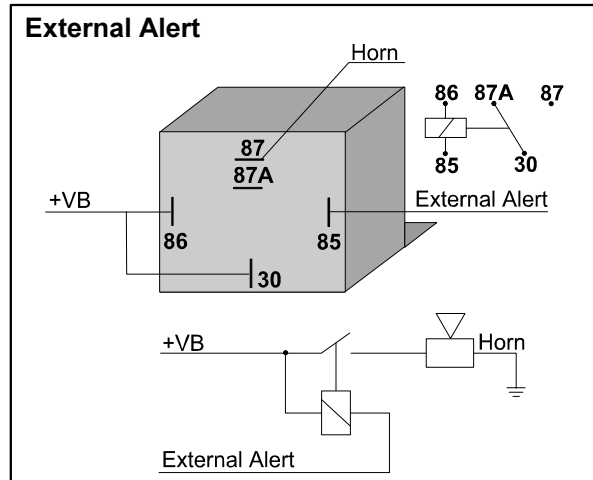
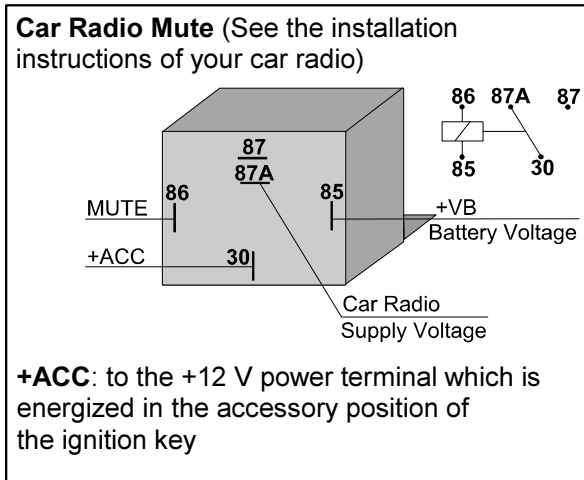
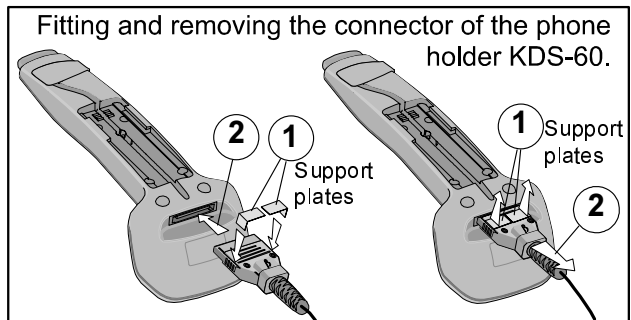

3.2.8 BENEBOOST KIT

The BeneBoost Kit is an extension for a car kit. It includes the BeneBoost car amplifier (TDB-60), a coaxial cable, a system cable and a power cable. The BeneBoost Kit sales package also includes an installation materials bag, which contains the necessary installation equipment. On the next page you will find a diagram of connections explaining how to install the BeneBoost Kit.

Caution:

The BeneBoost should only be installed by a Benefon authorized service centre. The end user should never attempt to install the BeneBoost without professional assistance. Professional installers have the required tools and knowledge for installing the BeneBoost properly and safely. The terms of warranty also require that the BeneBoost is installed by professionally trained personnel. Cable routing may cause interference with the components of the vehicle's electronic systems (such as ignition and braking systems). It is recommended that cables not be routed next to such electronic components.

3.2.8.1 BeneBoost

It is recommended that you place the BeneBoost in the trunk of the vehicle. There has to be enough dry, free space around and above the BeneBoost and there should not be any flammable materials nearby, because the BeneBoost can heat up to almost +80°C under extreme conditions. You should therefore place it at least 10 cm away from objects which might prevent its air circulation.

First slip the hex head screws into the slots of the BeneBoost and fasten the mounting plates with the nuts. Then fasten the BeneBoost car amplifier in the trunk with screws.

3.2.8.2 Coaxial Cable

Install the coaxial cable between the phone holder (KDS-60) and the PHONE plug on the BeneBoost.

Connect the antenna cable to the ANTENNA plug on the BeneBoost.

3.2.8.3 System Cable

Connect the system cable USB-connector to the BeneBoost and AMP-connector to the car box.

3.2.8.4 Power Cable

Obtain the necessary (+)-electrical current directly from the 12V battery of the vehicle. Connect the fuse chamber to the (+)-wire, near the cable end. If installation is made for a vehicle with a 24V electrical system, a 24V/12V DC converter must be used. In this case the (+)-wire should be connected to the +12V output of the converter.

The (+)-wire from the car kit, including its fuse chamber, will be connected to

(+)-wire of the power cable of the booster with a blade splice connector.

IMPORTANT: If you install the BeneBoost after the car kit, you must first remove the car kit (+)-wire of the power cable from the battery and attach it as mentioned above.

A Diagram of Connections

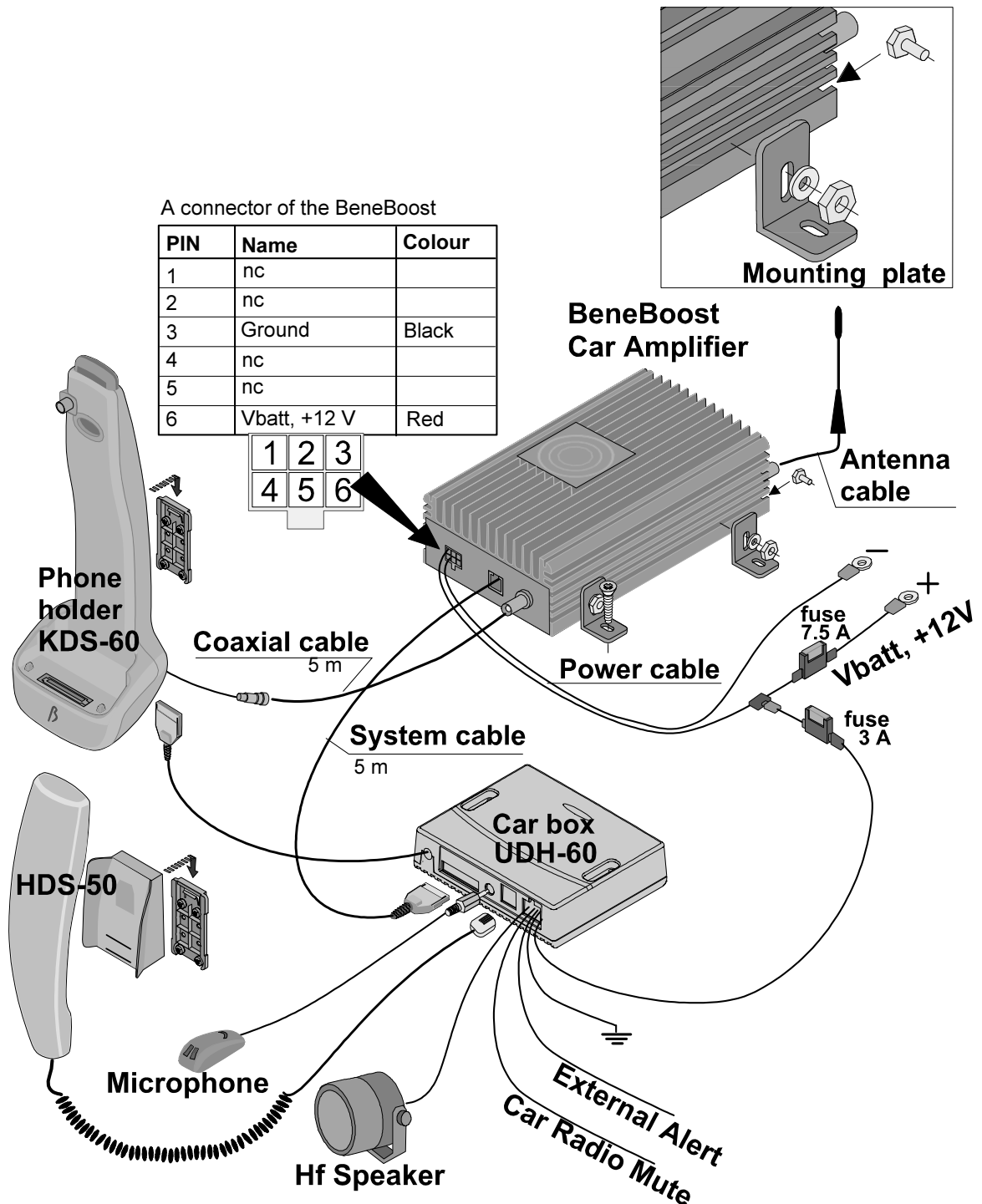

3.3 HF-FUNCTION

Benefon nSpica offers you hands free -setup for the Car Kit : the background noise tuning (CAR KIT TUNING) and MIC-ERP contrast tuning (CAR KIT SWING).

3.3.1 CAR KIT TUNING (theory)

You can set up the activation level of the microphone by using the CAR KIT TUNING option. The level is correct when the microphone path is activated by voice alone, and not, for example, by background noise in your car.

The following figure shows you the CAR KIT TUNING setup process.

a. If the CAR KIT TUNING is set too high, your voice (1) will not activate the microphone path properly, and the person at the other end will only hear interrupted transmission of speech.

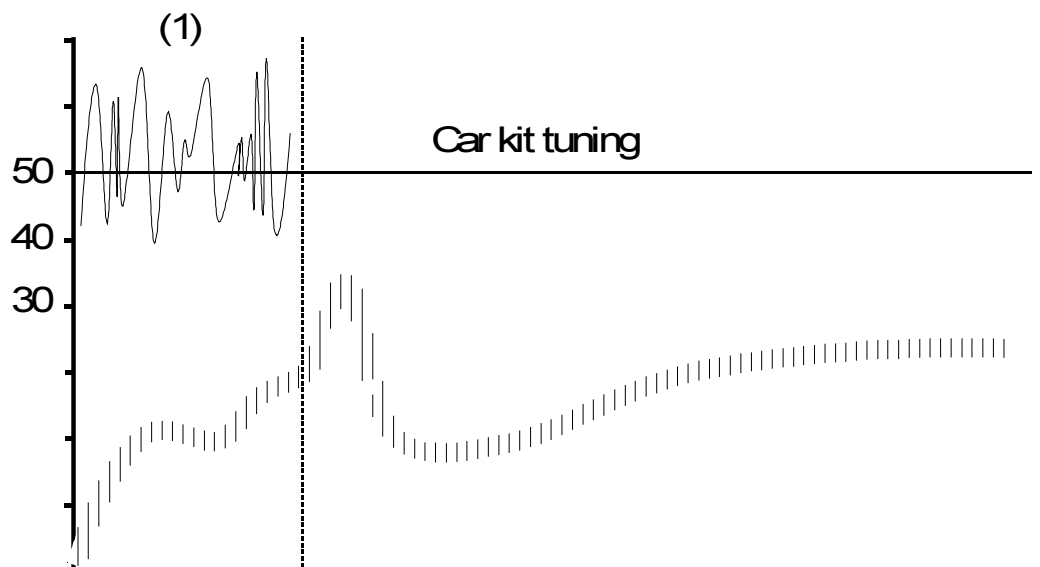

b. If the CAR KIT TUNING has been set up too low, the background noise in your car (2) will activate the microphone path, and the volume of the HF-speaker will be low.

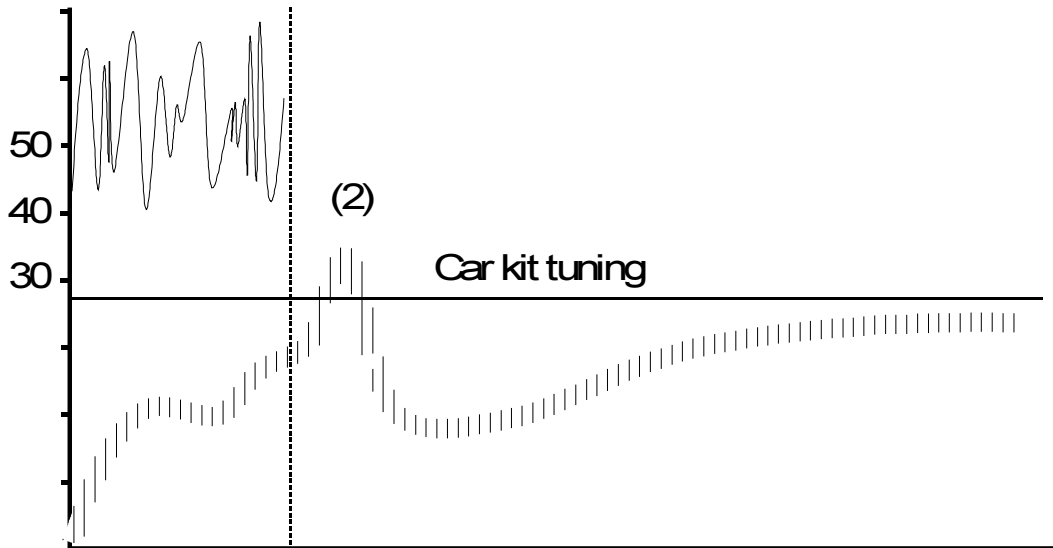

c. When the CAR KIT TUNING has been set correctly only your voice (1 & 3) will open the microphone path.

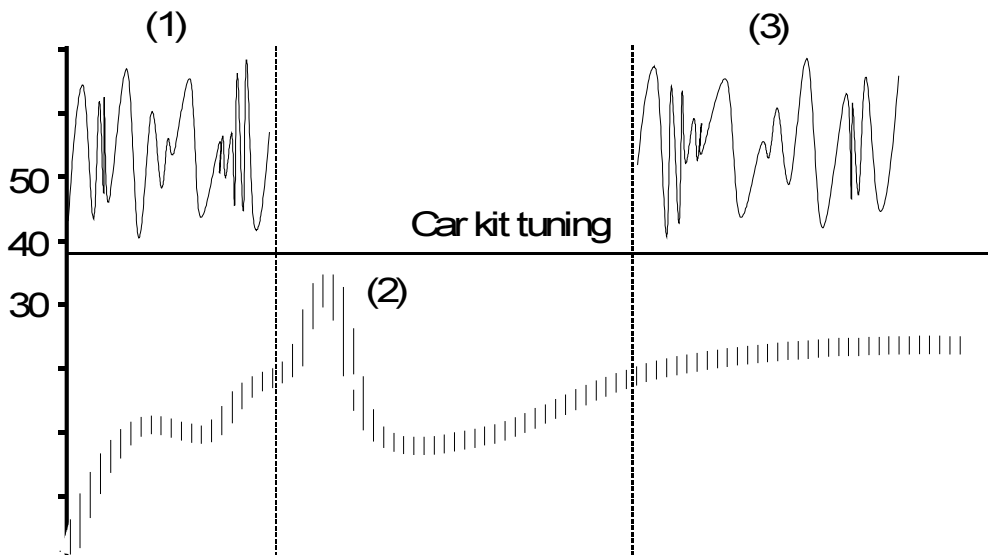

Benefon phones have been set in our factory so that they will function in most cars. The factory setting for the CAR KIT TUNING is 38. The recommended adjustment range is +/- 5 units from the factory setting.

3.3.2 CAR KIT SWING (theory)

The four-step CAR KIT SWING tuning is used to set the contrast of the microphone amplification/speaker attenuation swing. In the following figures the swing position while listening to the Car Kit is indicated by a solid line and the position while speaking into Car Kit the indicated by a dotted line.

a. With a tuning value of 4 it is possible to obtain the smallest difference between the amplification and attenuation of the microphone and speaker. This means that the connection is almost bidirectional. If the HF-function easily creates feedback, decrease the value of the CAR KIT SWING. By turning down the volume it is possible to reduce the occurrence of feedback.

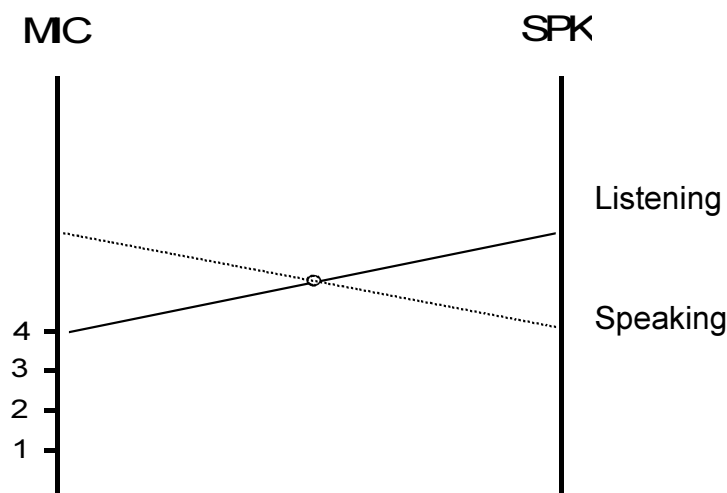

b. With a tuning value of 1 it is possible to obtain the greatest difference between the amplification and attenuation of the microphone and speaker. This means that the connection is almost unidirectional.

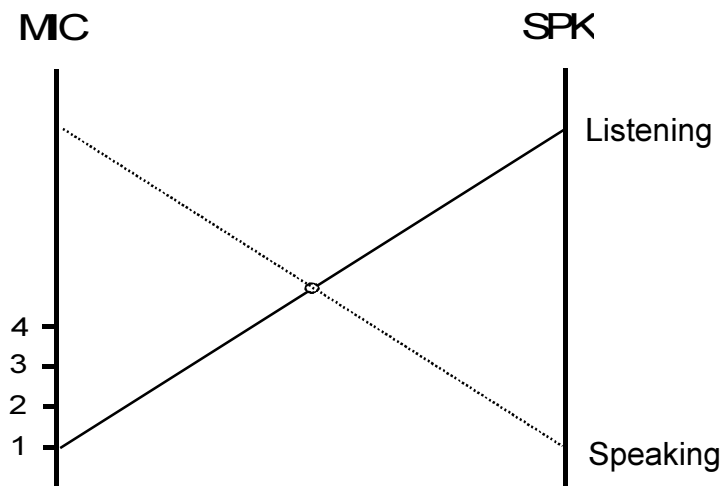











The factory setting for the CAR KIT SWING is 3.









3.3.3 HF-function tuning in practice

You can tune HF-functions two ways: manually or with car kit.

Manual tuning

1. Connect the localbox to your phone, and turn the phone on.
2. Press  and the following text will appear in the display: *****BENEFON*****.  will be flashing in the display.
3. Press   , and the following text will appear in the display:
HF-FUNCTION
4. Choose  SELECT, and the following text will appear in the display:
CAR KIT TUNING [038]. (The figure can be different).
5. Choose  CHANGE, and the following text will appear in the display:
CAR KIT TUNING [] (026). (The figure can be different).
6. Enter three digits and  SAVE. The recommended value is between 033 and 043.
7. Choose  SELECT, and the following text will appear in the display:
CAR KIT SWING (1...4): [3]. (The figure can be different).
8. Choose  SELECT, and the following text will appear in the display:
CAR KIT SWING (1...4): [3]. (3 is blinking)
9. Enter one digit and  OK.

Tuning in car kit

1. Connect the localbox to your phone, and turn the phone on.
2. Press  and the following text will appear in the display: *****BENEFON*****.  will be flashing in the display.
3. Connect the hand portable to the car kit
4. Press   , and the following text will appear in the display:
HF-FUNCTION
5. Choose  SELECT, and the following text will appear in the display:
CAR KIT TUNING [038]. (The figure can be different).
6. Choose  CHANGE, and the following text will appear in the display:
CAR KIT TUNING [] (026). (The figure can be different).
7. Drive the car so that you can get a normal back ground noise level. The figure (026) will be changed according the back ground noise level.
8. Enter three digits (back by pressing ) shown in the figure (xxx) and  SAVE. The level will be stored.

4.0 SERVICE APPLICATIONS

BeneWin

4.1 BeneWin SCA-60

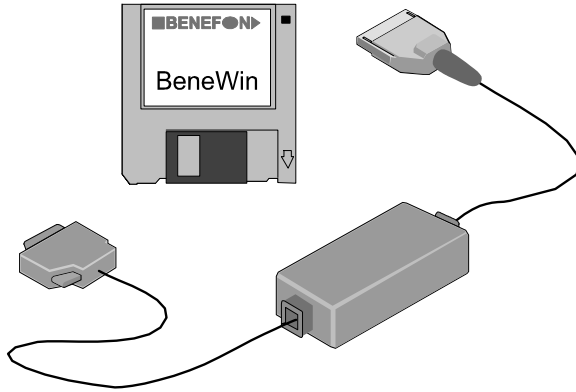

The BeneWin SCM Program for Windows is designed to facilitate maintenance of phone numbers and user settings on Benefon mobile phones. You can also use your phone to carry out the commands in the BeneWin Program, but it is handier to process data using your screen and keyboard - the advantage of the BeneWin Program. For example, all user settings are displayed in a single window, which enables you to check at a glance your current settings.

Your personal settings and phone numbers stored on the hard disk can be transferred to the mobile phone whenever necessary. When you travel or use a borrowed phone, your own settings make the phone feel like your own.

The main functions of the BeneWin Program are divided into four sections: THE BENEWIN MAIN WINDOW, in which you can modify the phone numbers, THE USER SETTINGS WINDOW, in which you can modify the phone's user settings, MAESTRO, in which you can compose or change last alert tone, SMS MANAGER, in which you can use SMS functions.

4.1.1 Installation of BeneWin program

Start Windows.

Insert the BeneWin installation disk in the floppy disk drive of your computer.

Using the Windows 3.1 choose **Run** from the **File** menu in the **Program Manager** and in the Windows 95 choose **Run** from the **Start** menu.

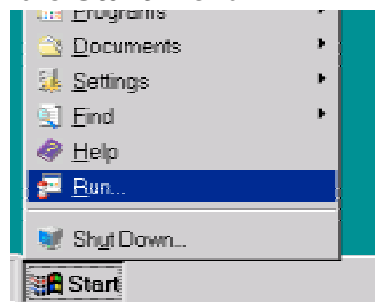
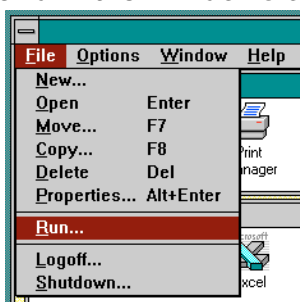

In the **Command Line** box, type the letter **A:** or **B:** to indicate your floppy disk drive, and then type **SETUP**. For example, **A:SETUP**.

Click the **OK** button, and follow the instructions displayed on your screen.

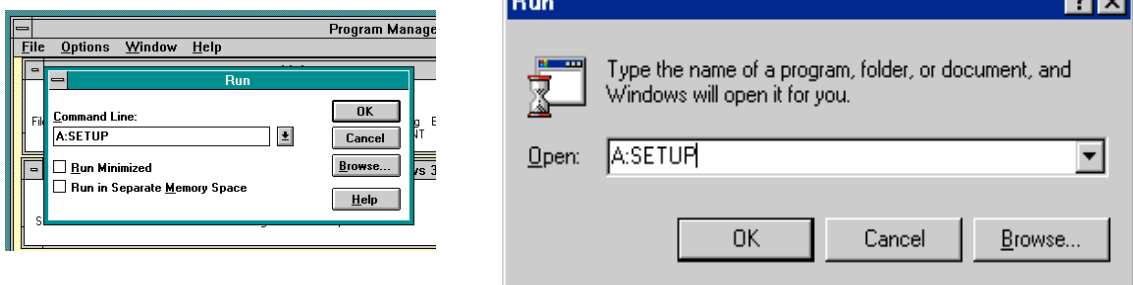

As normal it is recommended to close all other applications when installing new SW into hard disk. Only Windows should be running.

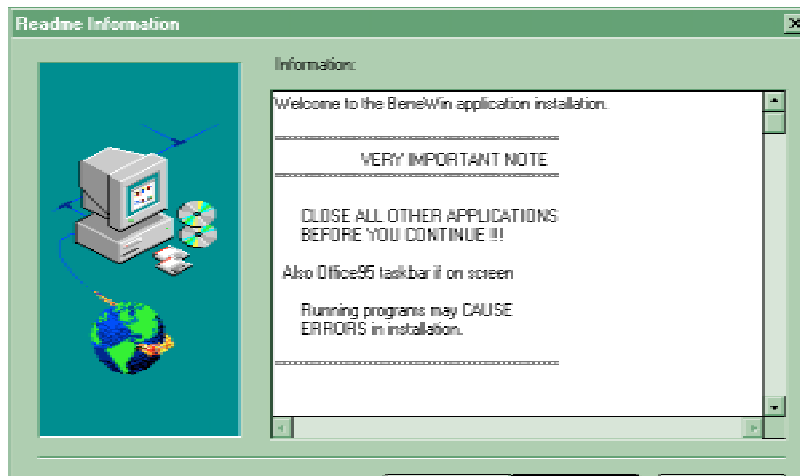

When you have confirmed that there is no other program running click **Next**.

On the second screen you will define the path where BeneWin will be installed. Default value is "**C:\Beneapp\Benewin**".

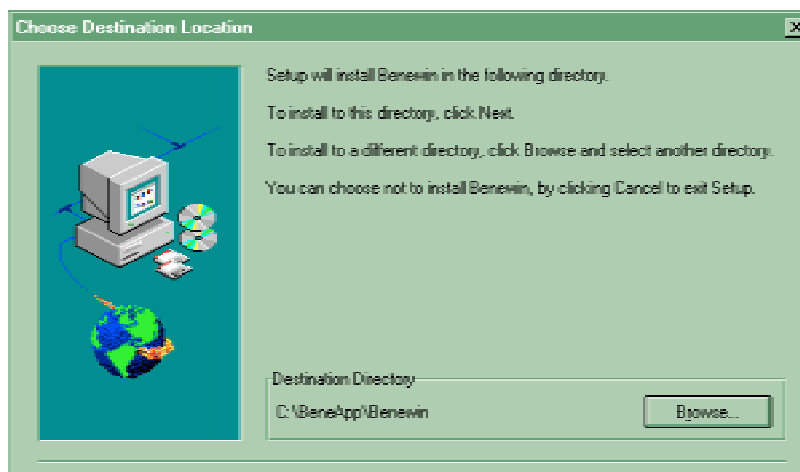

You may change the path if you wish. When ready click **Next**.

On the next phase you will determine Program Folder.

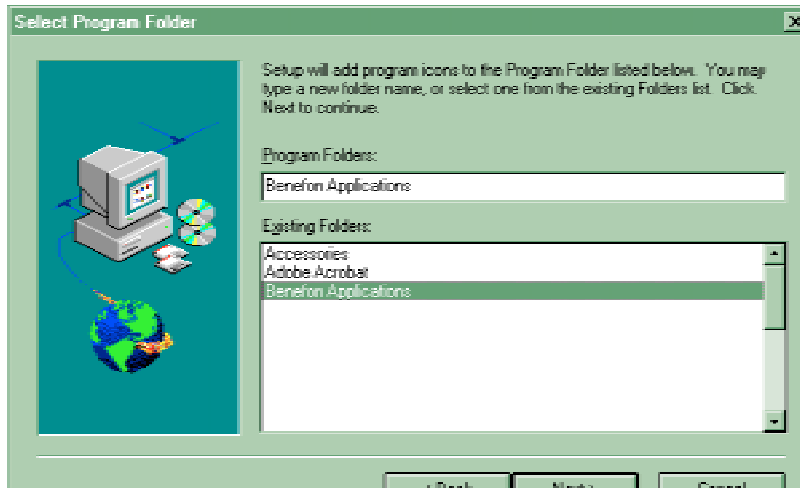

Default value is "**Benefon Applications**". You may choose some other Folder or even crate a new one. When done click **Next**.

Before the real installation starts you may accept or decline the settings.

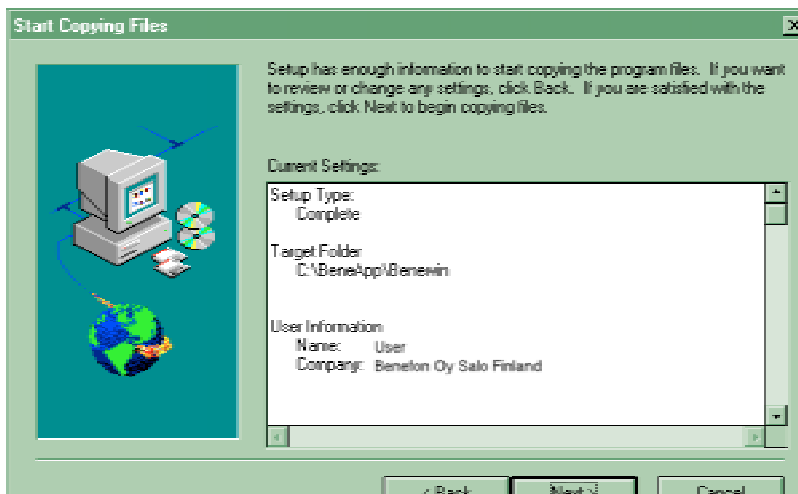

If you are satisfied click **Next** and the installation starts.

4.1.2 To start the BeneWin program

Connect your phone with a cable to the serial port of your computer, which is called COM1 or COM2. The serial ports are located in the back of your computer, and more precise instructions can be found in the manual accompanying the computer. Plug the flat end of the cable into the connector at the bottom of your phone. When the cable has been connected and the phone is functioning, you can start the BeneWin Program.

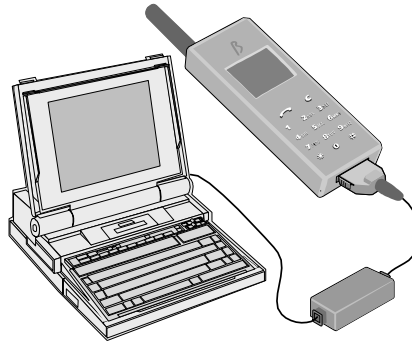

To start the BeneWin Program, double-click the BeneSCM icon.



If you use a laptop computer make sure that the computer is not in the energy saving mode. If so the energy saving mode may prevent the transfer of data from the phone to computer or vice versa.

After starting up the BeneWin program will guide you further with the help of an electric manual (**Online Help**).

4.2 BeneLoc

BeneLoc

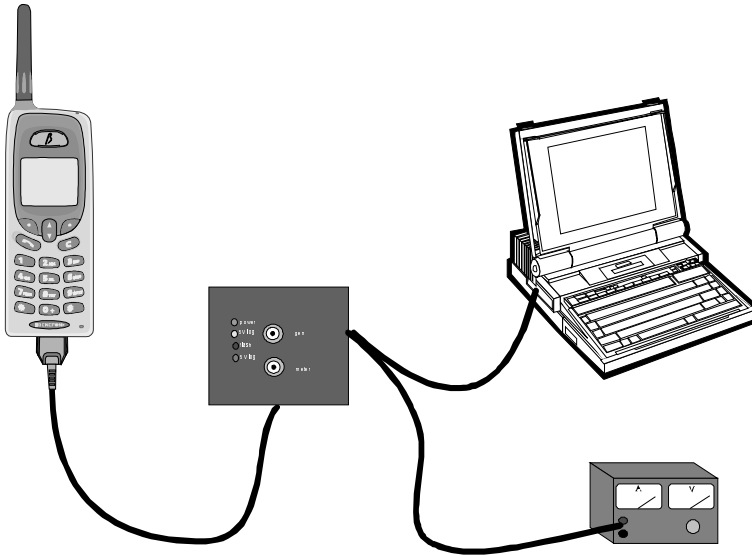

BeneLoc program is designed to help service person on tuning and service purpose. With Flasher Program you can change the software to Benefon phones.

Both, BeneLoc and Flasher program will need Local Box with service rights to work.

4.2.1 Installation of BeneLoc program

Start Windows. Close all other programs except **Program Manager**.

Insert BeneLoc Installation Disc 1 in the floppy disk drive of your computer. In the **Program Manager** window, choose **Run** from **File** menu.

Type the letter **A:** or **B:** to indicate your floppy disc drive, and then type **SETUP.EXE**. For example, **A:\SETUP.EXE**.

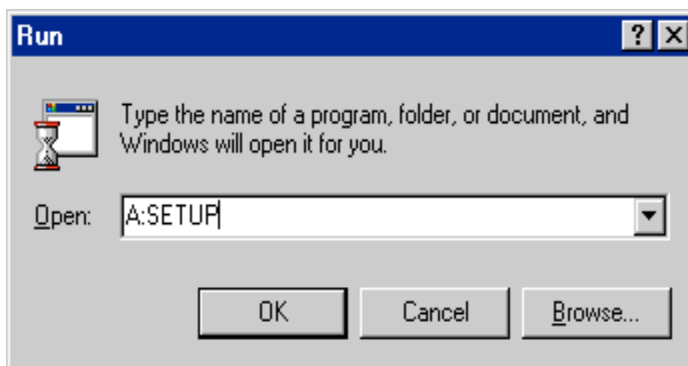

Click the **OK** button, and follow the instructions displayed on your screen.

The Setup Program will ask you to specify the drive and directory in which you want to install the BeneLoc Program. The Program suggests the following: **C:\Bene-**

App\BeneLoc. Accept the drive and directory by clicking **Next** button. You can also type your own directory for BeneLoc Program.

The Setup Program creates all necessary directories and subdirectories to your computer. Setup Program also creates its own group window in Program Manager.

4.2.2 To start the BeneLoc program

Connect the Service LocalBox to serial port of your computer, which is called COM1 or COM2. The serial ports are usually located in the back of your computer, and more precise instructions can be found in the manual accompanying the computer.

Switch off the phone. Plug the cable with flat connector into the connector at the bottom of the phone. When the cable has been connected and the phone is switched on, the phone should be in LOCAL mode. You can test this by pressing arrow button. There should be *****BENEFON***** on the display, if not, clean connectors and try again. When phone is in LOCAL mode you can start the BeneLoc Program.

To start the BeneLoc Program, double click the **BeneLoc** icon.

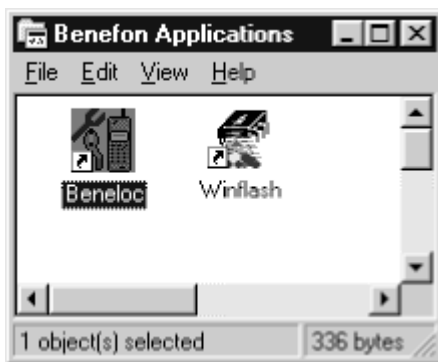

In the BeneLoc Startup window, first select the correct serial port. Then, you have to select type of the phone. You can also use the **Autodetect** option. After selection click OK to start BeneLoc Program. When operating without external power supply the phone may be on sleep mode and registration fails. You can wake up the phone by pressing some buttons on the phone.

4.2.3 Using the BeneLoc program

In the main window of the BeneLoc, you will find submenus and buttons. Clicking the buttons you can go to the submenus.

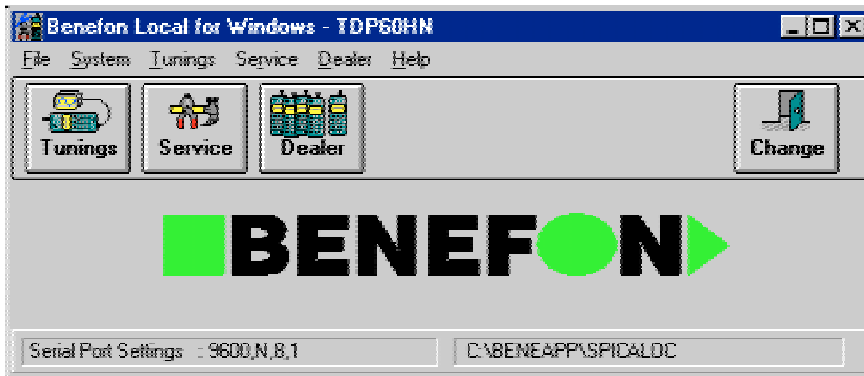

Change

For changing phone to another similar you do not need to do more than enter into main menu. It means that this button is not needed. If you are going to change the tested phone to one having different software in, clicking Change will start the registration protocol again.

Help

About BeneLoc submenu will tell you version of the BeneLoc Program and also the state of memory.

About Cellular submenu will show you information of the phone. Type of phones software, sales date, date of the software, serial number and present tuning values of the phone. You can not change the tuning values from Help menu.

Dealer

From Dealer submenu you can make or check programming of the phone. You will also find the SIS information from Dealer submenu.

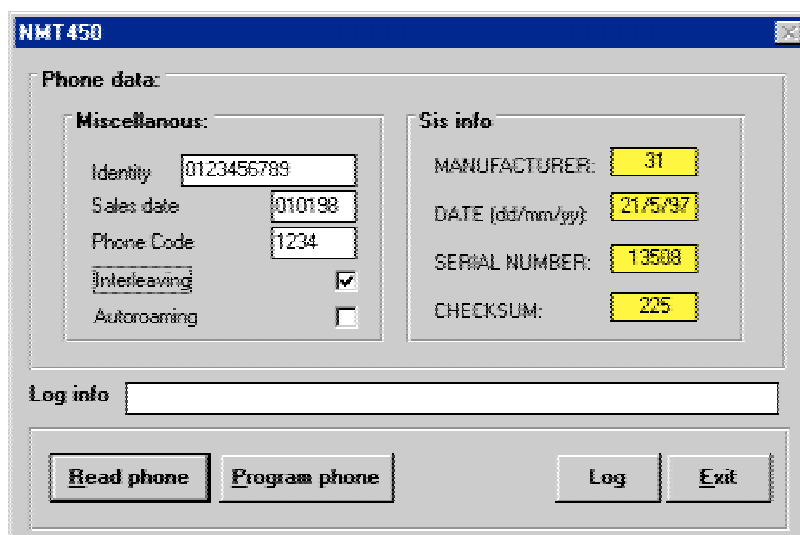

Service

You can control the audio lines (for example, switch Rx audio and compander on/off) in the Service main menu. It is also possible to control the phone to desired channel. There is also possible to change the power of transmitter.

In the **Ports** submenu is you can see the status of different digital ports. There is also possible to control some of the output ports.

You can read the status of the A/D converters from the **A/D** submenu. Select 8 different topics to view. By clicking **SCAN AD** button The Beneloc will scan A/D the state of converters continuously. Scanning can stopped by clicking **STOP AD**.

Memory submenu allows you to make **Ram** reset.

By clicking **Initialize** You can clear all LOCAL settings in service menu.

Home button will return you back to main menu.

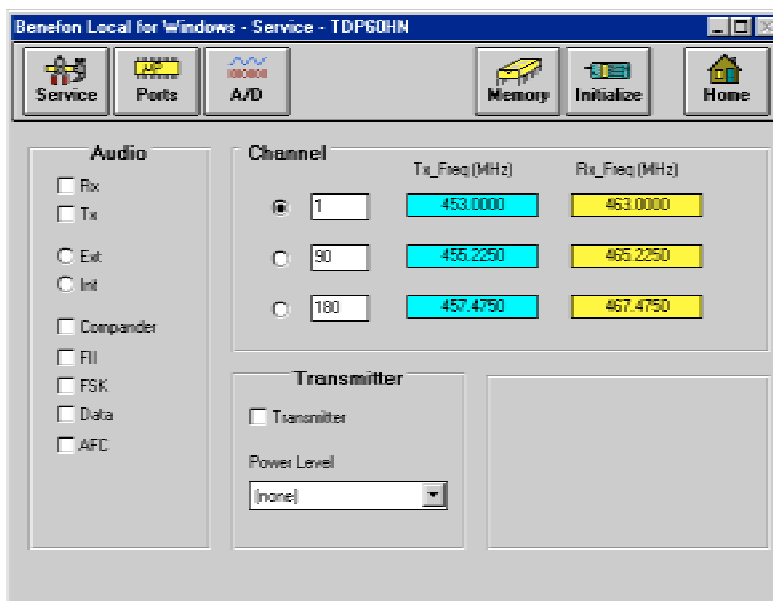

Tunings

From Tunings main menu you can select different tunings to do. Every tuning have they own instruction window. Follow given instructions to do tunings. Clicking **START** will start tuning. The value will be stored only by clicking **SAVE**. Some of the tunings are chained and you can enter to next phase by clicking **NEXT**.

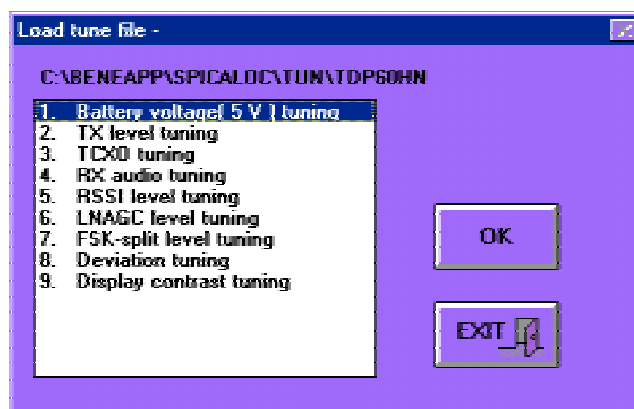

System

You select used mobile phone system from this submenu.

File

From **settings** submenu you can manually change settings of the communication port.

5.0 PHONE'S CONSTRUCTION

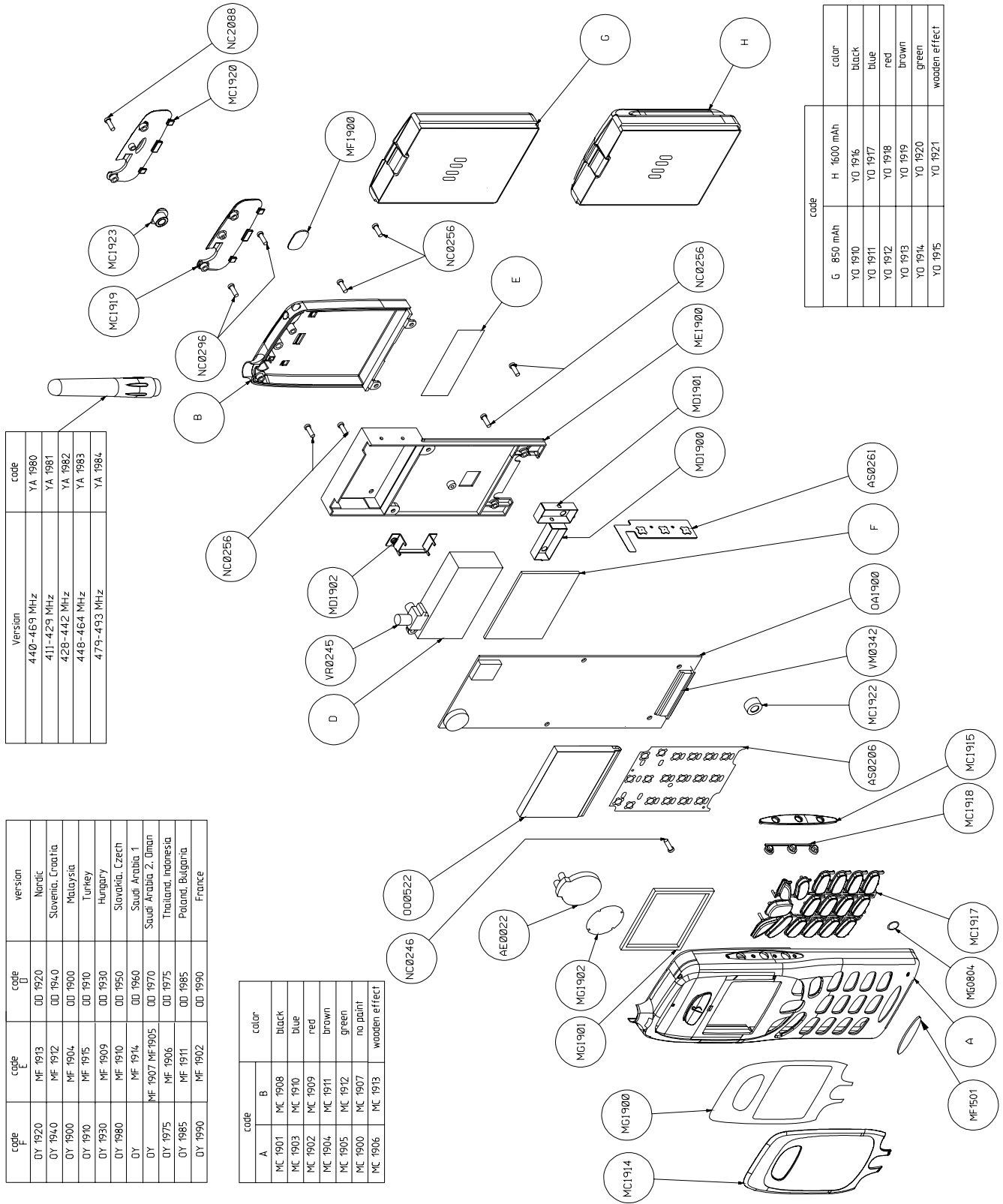

code		H	1600 mAh	color
G	850 mAh	YD 1910	YD 1916	black
		YD 1911	YD 1917	blue
		YD 1912	YD 1918	red
		YD 1913	YD 1919	brown
		YD 1914	YD 1920	green
		YD 1915	YD 1921	wooden effect

Version	code
440-469 MHz	YA 1980
411-429 MHz	YA 1981
428-442 MHz	YA 1982
448-464 MHz	YA 1983
479-493 MHz	YA 1984

code E	code U	version
MF 1913	00 1920	Nordic
MF 1912	00 1940	Slovenia, Croatia
MF 1904	00 1900	Malaysia
MF 1915	00 1910	Turkey
MF 1909	00 1930	Hungary
MF 1910	00 1950	Slovakia, Czech
MF 1914	00 1960	Saudi Arabia 1
MF 1907 MF 1905	00 1970	Saudi Arabia 2, Oman
MF 1906	00 1975	Thailand, Indonesia
MF 1911	00 1985	Poland, Bulgaria
MF 1902	00 1990	France

code		color
A	B	
MC 1901	MC 1908	black
MC 1903	MC 1910	blue
MC 1902	MC 1909	red
MC 1904	MC 1911	brown
MC 1905	MC 1912	green
MC 1900	MC 1907	no paint
MC 1906	MC 1913	wooden effect

5.1 LOGIC / AUDIO

OA1900 Processor/Audio

PROCESSOR

5.1.1 General

The entire radio audio and processor functions are found within a single PA1900 board, through which all other modules are connected. Only the RF signals have a different unit.

The processor controls the audio and radio (RF) modules, internal devices and external accessories.

The μ CBIC (processor-asic) includes:

μ CBIC	IG3010	H8/300H-cpu, 10k*8 CMOS RAM, 8 A/D, 4 D/A, 48 pcs I/O lines, 3 series-interfaces, 2 modem-interfaces, i2c-interface, frequency counter, realtime clock
PROM	29LV004	512k*8 EEPROM, program memory
SIS	IG2048	Asic for SIS-function, 256k*8 EEPROM + Universal EEPROM for tuning values

5.1.2 Connectors:

5.1.2.1 Radio Base Connector, V101

1	SV_SHG	charge voltage for battery	6 - 8V / max 1,1A
2	SV_SHG	charge voltage for battery	6 - 8V / max 1,1A
3	SVB	battery voltage to accessory	4 7,5V / max 0,3A
4	SV-PROG	flash programming voltage	0.5/12 -14 Vdc
5	SEXTMIC + PWR	external audio signal from the accessory + power on/off control (3V = pwr on)	200 mVrms
6	GND	ground	
7	GND	ground	
8	EXTERP + HOOK	external audio signal to the accessory	100mVrms
9	SCADET	accessory identify (carkit, table charger, booster)	0/VCC digital
10	SI2CINT	i2c interrupt	0/VCC digital
11	SSCL	i2c clock	0/VCC digital
12	SSDA	i2c data	0/VCC digital
13	STXD	rs232 output	0/VCC digital
14	SRXD	rs232 input	0/VCC digital
15	SEXTIO	headset identify IO	0/VCC digital
16	SCHGCONT	charger control	0 - VCC

The Ext-hook switch is connected to the erp-line so that the erp-line dc level drops when the handset is in its holder.

5.1.2.2 Accu module, V102

1	A_VB	power supply voltage from the battery	5V
2	A_BATD	battery pack data	0/VCC
3	A_MC	Extra control-line	0/VCC
4	GND		

5.1.2.3 RF-module, V103

1	S_SDATA	synthesizer control data	0/VCC
2	S_SCLK	clock signal for synthesizer control data	0/VCC
3	S_SLE	enable pulse to the synthesizer	0/VCC
4	S_RX_REG	control line for VRX-regulator	0/VCC
5	S_TX_REG	control line for VTXS-regulator	0/VCC
6	S_AFC	frequency compensation control voltage	approx 1.5V
7	S_SNTC	temperature data, analog	0-VCC
8	S_RXAUDIO	received audio signal	230 mVrms
9	S_RSSI	received signal strength indicator, analog	0-2V
10	GND	v	
11	s450K	450kHz for AFC detector	approx 1Vpp
12	GND	ground	
13	BCNTL_A	booster power level setting	approx 1V / 0.1V
14			
15	VB	power supply voltage from the battery	5V
16	VB		
17	VB		
18	S_TXBIAS	power on/off control, (0V = TX OFF)	0/VCC
19	S_TXPWR	TX power level control, analog	0-VCC
20	S_TXAUDIO	transmitter audio signal	200 mVrms

5.1.2.4 Side switch module, V104

1	KEYOUT3	key matrix output (volume key +)	0/VCC
2	PWRKEY	powerkey	
3	GND		
4	KEYINP0	key matrix input (volume keys +/-)	0/VCC
5	KEYOUT2	key matrix output (volume key -)	0/VCC

5.1.2.5 Display module, A200

1...7	nc	not connected	
8	VCC	power supply voltage	3.3V
9	RESET	reset-line (low active)	0/VCC
10	GND	ground	
11	DCSI	chip select (low active)	0/VCC
12	VCC	power supply voltage	3.3V

13	VCC	power supply voltage	3.3V
14	DAO	L:control data H:display data	0/VCC
15...17	VCC	power supply voltage	3.3V
18...23	nc	not connected	
24	DSCL	serial clock line for data	0/VCC
25	DSI	serial data input	
26	GND	ground	
27...34		connected to the voltage components	
35	VCC	power supply voltage	3.3V
36...40		connected to the voltage components	
41	nc	not connected	

5.1.2.6 Circuit Diagram

The processor and audio circuits diagram is split into four parts. Signals in the circuit diagrams have been given names, and signals with the same name are connected between diagrams (<x> = page).

Page	1 of 5	module connector pins
	2 of 5	power supply + display
	3 of 5	μ CBIC, EPROM, SIS-function
	4 of 5	audio parts

5.1.3 Functions

5.1.3.1 μ CBIC

I302 is itself a processor-asic circuit. It is comprised H8/300H-cpu, 10k*8 CMOS RAM, 8 A/D, 4 D/A, 48 pcs I/O lines, 3 series-interfaces, 2 modem-interfaces, i2c-interface, frequency counter, realtime clock, timers and 4, 8 MHz clock oscillator. The μ CBIC divides this by 4 to get timing signal E.

When the processor is operating, RESET = VCC, VCC = 3.3V, E = 1,2MHz.

5.1.3.2 Memories

Memory and external I/O-circuit address coding is done with the μ CBIC circuit I302. The circuit options CE, OE and WE are 0-active.

The program memory is in 512k*8 EPROM. The program uses the addresses 2100H 3E8000H.

RAM-memory is 10k*8 CMOS RAM and included to the μ CBIC. μ CBIC use own power supply voltage which is VRAM and that is always operating, even when the radio is in the OFF state.

5.1.3.3 The Modem

The FFSK modem is located in the audio circuit. The modem is connected to the μ CBIC by a series line, input to synchronised port, and transmission is

controlled by an μ CBIC series output. The modem gives a 1200 Hz signal RXCLK and TXCLK to the μ CBIC. There is a data detector within the modem, the speed of which is controlled by C413. The μ CBIC A/D converter measures the level of acceptance from ERPDET line. The same detector also serves to control HF function.

5.1.3.4 AFC

The AFC function is performed by an internal μ CBIC frequency counter. A 450 kHz intermediate frequency is amplified to a square-wave form by Q303. The frequency is adjusted by μ CBIC D/A 1 signal. This approx. 1,5 Vdc voltage is fed to the synthesiser AFC pin.

5.1.3.5 Sleep Timer

The phone puts the central functions to sleep for a time. Although everything seems normal to the user, most of the functions are closed down. The radio and audio units are closed down completely. The processor still has a power supply, but the processor is halted and has minimal power consumption. Only the μ CBIC circuit sleep timer and its 32 kHz crystal oscillator remain in active mode. The phone is "woken up" by interrupting the sleep timer or by changing the keyboard state. The sleep timer 32 kHz clock frequency is produced by the oscillator made by crystal X302.

5.1.3.6 Warm start

C330 and R329 measure the length of a voltage break. The voltage drops during a break, after which it is measured by the A/D (AN2) converter. The time constant is approx. 10 s. Thus a "warm start" is detected.

5.1.3.7 Reset

The main voltage (VCC) regulator I202 PG output resets (stops) the processor and zeroes the controls when the battery voltage drops below 3.3V. When the voltage rises again, the processor restarts.

5.1.3.8 Power Switch

The power switch (PWRKEY) is grounded, and directs the regulator I202 to conduct when pressed. The program commences and checks the PWRSW line to ensure that the switch is being pressed, and sets hold on the regulator for the PWRON line. When the switch is depressed for a longer time, the program directs power to the PWROFF line. During a short voltage break, C221 and R221 remember the previous control, i.e. fet Q204 conducts again when the voltage is restored within 10 seconds. The switch-fet also serves as a watch-dog should the voltage drop or processor error-state continue; after 10 seconds, the radio will shut down completely.

Note! The μ CBIC circuits have their own power supply voltage connected to the battery to ensure an uninterrupted power supply. The μ CBIC power supply

is ensured during a battery-back change by the battery B200.

5.1.3.9 Battery Voltage Measurement

The battery voltage is measured by an A/D converter (AN7). The converter 256 step conversion scale is not sufficient as it stands, so the measured range is restricted to 4.8V by the operational amplifier I301. The reference voltage for the measurement is provided by the main regulator 3.3V supply. Calibration is done by the program against a precisely known battery voltage.

5.1.3.10 I/O ports

The μ CBIC I/O ports PA PF are 8-bit hold circuits. Data is fed to the addressed output. When the RESET line is down (0V) all the μ CBIC ports are zeroed (0V). As RESET rises again, all of the two-way I/O ports are inputs until the program sets them to the desired state. With the radio in OFF state, RESET is down so all of the controls are also down although μ CBIC is still provided with operational voltage VRAM.

5.1.3.11 SIS

SIM is performed by a BENEFON ASIC IG2048 manufactured by Atmel. Integrated circuit IG2048 is E2 logic array. This type of array incorporates both an electrically erasable and programmable read only memory (EEPROM) and a gate array for SIM function.

SIM has 256 bytes internal EEPROM divided to two parts: 224 bytes EEPROM for universal use and 32 bytes EEPROM for SIS calculations are secured by programmable fuse function.

User specific information is stored in EEPROM which CANNOT be read from outside the chip. All external attempts to read the information clear both. EEPROM and RAM (fill with FF).

5.1.3.12 Power Adjustment

The transmitter control logic switches TX power and also adjusts it to the correct level. The S_TXREG signal sets the transmitter to ready mode. Power is controlled by the μ CBIC analog output A/D 0. 0V corresponds to "no power" and 3.3V to maximum transmitter power. The power levels are calibrated by the program at the source of measurement.

5.1.3.13 Charging Control

The charger is controlled by the program. The charger is detected by a voltage at the SV-CHG pin. The charging current (0.1, 1A) is controlled by an analog output (0.4, 2.0V) CHGCONT signal which comes from μ CBIC DA3 pulse frequency output. Charging is governed by the battery and radio temperatures, battery voltage and time measurement. Every time when charger is connected to the radio base connector this charger give approx. 3 second maximum current (that help if battery is empty).

5.1.3.14 Temperature Measurement

The radio has two separate temperature sensors, one within the battery pack, and the other within the radio module. Inside the radio the NTC resistor R323 voltage is measured by the μ CBIC A/D converter (AN6). This value is converted by a programmed table to a temperature reading.

5.1.3.15 Real-time Clock

A real-time clock is provided within μ CBIC to give the time and date. The alarm function can also be programmed to the ALARM pin. This will initiate the main regulator and thus also the radio although it is in OFF state.

The μ CBIC circuit has a continuous power supply and the 32 kHz clock crystal runs constantly. Not even the RESET line stops the clock. If the power supply has dropped too low, the clock will need to be reset with the radio buttons (from the menu).

Audio

5.1.4 Function Description

OA1900 Audio

The audio module is comprised of the following functions:

1. TX-audio signal handling
2. RX-audio signal handling
3. Fii signal handling
4. FFSK modem
5. DTMF generator/receiver
6. Signal level detectors
7. Compander
8. Expander
9. Buzzer

The audio functions are mainly located in a single circuit AK2339. This chip from AKM is controlled by a serialbus. It is possible to shut down parts of the circuit, one block at a time to minimise power consumption.

5.1.5 TX-audio

The input from the microphone is fed to the audio circuit I401 pin 61, which is an operational amplifier (AMP1) inverting input. The operational amplifier gain is set by resistors R403 and R404. The amplifier is connected as a low pass filter. After the amplifier is the microphone switch and then summing junction of MIC input signal, EXTMIC input signal and transmit DTMF signal. VR1 is a programmable amplifier, which sets the microphone signal (sensitivity) to the correct level. After VR1 comes band-pass filter for transmitting the voice signal. TXDET is the transmit voice signal detection circuit which works as a full wave rectifier. Next comes ATT1 which is an attenuate circuit to set the transmit signal level in the HF-mode. COMP is the compressor circuit. Compress the transmitting signal amplitude with square root law. It can be hypassed. The linearity is adjustable by the control register CVR. Next is VR2, normal deviation gain control circuit to set the signal level. The P/E & LIMIT pre-emphasis circuit and limiting circuit, emphasize the higher frequency component of the signal in order to improve the signal-to-noise ratio of modulated signal. This block includes a limiting circuit for signal amplitude in order to confine the maximum deviation of the transmit modulated signal. Before TXLPF is the FFSKTX switch. TXLPF is the low pass filter to reject the higher frequency component on the transmit signal. VR3 is a maximum

deviation gain control circuit to set the transmit signal level. After the VR3 comes switch TXAUDON, which mutes the tx-audio signal using the TXMUTE control. From the switch, the signal is fed to the summing junction (ADD3) of the tx-audio signal and Fii-signal. Next comes VR4 gain control circuit to set. SMF1 is smoothing filter for tx-audio signal. The tx-audio signal is then fed to the V102 connector pin 20.

5.1.6 RX-Audio

The rx-audio signal coming from the receiver through the V103 pin 8 is fed to the audio circuit I401 pin 23. Inside the circuit, the signal is fed to the operational amplifier (AMP2) inverting input. The amplifier gain is set by resistors R431 and R432. The signal is next passed through an anti-aliasing filter. VR5 is a gain control circuit to set the rx-audio signal to the correct level. Next comes de-emphasis (D/E) circuit. Equalize the pre-emphasized rx-audio signal. The signal passes from the D/E through the switch RXAUDON. RXBPF is the band-pass filter for the rx-audio signal. RXDET is the rx-audio signal detection circuit. This circuit works as a full wave rectifier. After the RXBPF comes I402 which is the split-switch of audiosignal and then expander circuit (EXP). Expand the rx-audio signal amplitude. It can be bypassed. The linearity is adjustable by the control register EVR. VR6 is a gain control circuit to set the rx-audio signal to the correct level. After VR6 comes the RXMUTE switch, which is operated by the RXMUTE control. ADD4 is the summing junction of the rx-audio signal, external signal (not used), DTMF signal and transmit signal. VR10 is the volume control circuit to set the level of earphone and external earphones. The rx-audio signal is connected through the receiver driver (RECAMP) to the earphone.

5.1.7 FII Signal

The NMT system uses the FII signal to check the radio path quality. This approx. 4kHz signal is split from the rx-audio signal after the VR5 and is filtered through the band-pass filter (FBPF). VR7 sets the FII signal to the correct level. Switch FILOOPON can be operated by the FIION control, to be summed with the tx-audio signal before the VR4.

5.1.8 FFSK Modem

The FFSK data signal from FFSK modulator to be transmitted is passed through the FFSK low-pass filter and pre-emphasis (FFSKP-EM) to the VR9, which adjusts its level. The data signal is switched using switch FFSKTXON.

The received data signal is split from the rx-audio signal after the de-emphasis circuit. The data signal is fed through the FFSK band-pass filter to the FFSK demodulator and FFSK data detector.

FFSK DET block. The block works to judge the FFSK signal existence by comparing the amplitude of the noise reduced FFSK signal and the provided

detection level standard. Once the detector judges a valid FFSK signal, 'H' signal is put out on the FFSKDET pin (pin43). The data detector speed is determined by the external condensator C413.

FFSK DEMOD. To recover 1200bps receive data and clock from the FFSK signal.

The modem is connected to the CPU by series lines, the receiver to a synchronised gate, and transmission is directed to an ASIC series output. The modem provides a 1200 Hz clock signal RXCLK to the processor and TXCLK to ASIC.

5.1.9 The DTMF Generator/Receiver

The DTMF generator provides all sixteen standard DTMF tones, and each individual frequency separately. The generator is used to produce both key and alarm tones and enable numeric message transmission during a call.

Key and alarm tones are taken from the generator to switch DTMFRXON and is summed with the rx-audio signal. Key tones are connected to earphone and external earphones.

When transmitting a numeric message, the DTMF tones produced by the generator are fed through the VR8, which set the DTMF signal level to the switch DTMFTXON, and then the signal is summed with the tx-audio signal.

The DTMF receiver takes in numeric messages sent to the phone. The route to the DTMF receiver splits from the rx-audio signal after the summing junction ADD4.

5.1.10 Signal level detectors

Audio signal level detectors are required for the HF-function to measure the transmitted and received audio signal level, and to study the data signal level. Measurement is done by rectifying the signal, and the resultant DC voltage is read by a phone's processor A/D converter. TXDET is at the transmission side detector and RXDET is at the receiver side detector.

5.1.11 Compander/Expander

Compander and expander units are included in audio asic I405 and can be controlled by registers.

5.1.12 Alarm buzzer

Tones for the internal alarm tones are provided by the DTMF generator. The internal alarm tones path way is DTMF generator, VR8, switch DTMFRXON, summing junction ADD4, VR11, AMP5 and buzzer. The buzzer volume is controlled by the DA3.

5.1.13 The other in audio asic (I401)

OSC is the main oscillator and clock divider for the processor.

CLKBUF is clock buffer generate clock out from main clock.

INTERFACE & DATA REGISTER is a 16 bit address/data serial interface circuit.

BIAS is bias current generator for amplifiers.

TIMER is an 8 bit timer (not used).

DA1, DA2, DA3 are 8 bit linear DA converters.

5.1.14 Parts list OA1900

OA1900 Proc./Audio

CODE	PART	DESCRIPT.	VALUE	MANUF.	TYPE
OO0522	A200	Matrix display module	Vcc 3.3V	Alps	??????
AE0017	A401	Buzzer	13x11x3mm 1.5V/80mA	Primo	MB-11A-K
AM0063	A405	Microphone	Electret condenser-+65-+3dB	Primo	EM134K
AE0022	A406	Dynamic transducer	20*3.2mm DC=150ê	AKG	IMXR 2601A0001
AB0036	B200	Lithium battery	3V 39mAh	Rayovac	BR 1225SR2-B
CG0101	C100	SMD capasitor X7R	100pF ñ5%	Murata	
CG0471	C101	SMD capasitor X7R	470pF ñ10%	Murata	
CG0471	C102	SMD capasitor X7R	470pF ñ10%	Murata	
CG0471	C103	SMD capasitor X7R	470pF ñ10%	Murata	
CG0471	C104	SMD capasitor X7R	470pF ñ10%	Murata	
CG0471	C105	SMD capasitor X7R	470pF ñ10%	Murata	
CG0471	C106	SMD capasitor X7R	470pF ñ10%	Murata	
CG0471	C107	SMD capasitor X7R	470pF ñ10%	Murata	
CG0471	C108	SMD capasitor X7R	470pF ñ10%	Murata	
DT1840	C109	Transient voltage suures	sor 18V/30A	AVX	VC060318A400
DT1840	C110	Transient voltage suures	sor 18V/30A	AVX	VC060318A400
DT1840	C111	Transient voltage suures	sor 18V/30A	AVX	VC060318A400
DT1840	C112	Transient voltage suures	sor 18V/30A	AVX	VC060318A400
CG0471	C113	SMD capasitor X7R	470pF ñ10%	Murata	
CG0471	C114	SMD capasitor X7R	470pF ñ10%	Murata	
CG0102	C115	SMD capasitor X7R	1nF ñ10%	Murata	
CG0121	C140	SMD capasitor X7R	120pF ñ5%	Murata	
CG0101	C142	SMD capasitor X7R	100pF ñ5%	Murata	
CG0151	C143	SMD capasitor X7R	150pF ñ5%	Murata	
CG0102	C144	SMD capasitor X7R	1nF ñ10%	Murata	
CG0101	C145	SMD capasitor X7R	100pF ñ5%	Murata	
CG0223	C200	SMD capasitor X7R	22nF 20%	Murata	
CD0104	C201	SMD capasitor	100 nF 10% 50 V X7R	Philips	
CH0105	C202	SMD capasitor	1uF/-20/+80%/16V	TaiyoYuden	EMK212 F105Z00T
CH0105	C203	SMD capasitor	1uF/-20/+80%/16V	TaiyoYuden	EMK212 F105Z00T
CH0105	C204	SMD capasitor	1uF/-20/+80%/16V	TaiyoYuden	EMK212 F105Z00T
CD0104	C205	SMD capasitor	100 nF 10% 50 V X7R	Philips	
CD0104	C206	SMD capasitor	100 nF 10% 50 V X7R	Philips	
CD0104	C207	SMD capasitor	100 nF 10% 50 V X7R	Philips	
CD0104	C208	SMD capasitor	100 nF 10% 50 V X7R	Philips	
CU3106	C211	SMD tantal	10uF / 6V +-20%	AVX	TAJA106M006R
CG0223	C212	SMD capasitor X7R	22nF 20%	Murata	
CG0223	C218	SMD capasitor X7R	22nF 20%	Murata	
CU3106	C221	SMD tantal	10uF / 6V +-20%	AVX	TAJA106M006R
CH0105	C223	SMD capasitor	1uF/-20/+80%/16V	TaiyoYuden	EMK212 F105Z00T
CU3106	C225	SMD tantal	10uF / 6V +-20%	AVX	TAJA106M006R
CG0223	C226	SMD capasitor X7R	22nF 20%	Murata	
CG0223	C301	SMD capasitor X7R	22nF 20%	Murata	
CG0223	C302	SMD capasitor X7R	22nF 20%	Murata	
CG0223	C303	SMD capasitor X7R	22nF 20%	Murata	
CG0223	C311	SMD capasitor X7R	22nF 20%	Murata	
CG0220	C314	SMD capasitor NPO	22pF ñ5%	Murata	
CG0220	C315	SMD capasitor NPO	22pF ñ5%	Murata	
CG0220	C316	SMD capasitor NPO	22pF ñ5%	Murata	
CG0220	C317	SMD capasitor NPO	22pF ñ5%	Murata	
CU3106	C321	SMD tantal	10uF / 6V +-20%	AVX	TAJA106M006R
CG0223	C322	SMD capasitor X7R	22nF 20%	Murata	
CG0102	C323	SMD capasitor X7R	1nF ñ10%	Murata	
CG0223	C324	SMD capasitor X7R	22nF 20%	Murata	
CG0223	C325	SMD capasitor X7R	22nF 20%	Murata	

CODE	PART	DESCRIPT.	VALUE	MANUF.	TYPE
CG0223	C326	SMD capasitor X7R	22nF 20%	Murata	
CG0103	C328	SMD capasitor X7R	10nF ñ10%	Murata	'
CU3106	C330	SMD tantal	10uF / 6V +20%	AVX	TAJA106M006R
CG0103	C341	SMD capasitor X7R	10nF ñ10%	Murata	'
CH0105	C342	SMD capasitor	1uF/-20/+80%/16V	TaiyoYuden	EMK212 F105Z00T
CH0105	C343	SMD capasitor	1uF/-20/+80%/16V	TaiyoYuden	EMK212 F105Z00T
CG0103	C344	SMD capasitor X7R	10nF ñ10%	Murata	'
CG0103	C352	SMD capasitor X7R	10nF ñ10%	Murata	'
CG0223	C361	SMD capasitor X7R	22nF 20%	Murata	'
CG0103	C372	SMD capasitor X7R	10nF ñ10%	Murata	'
CG0103	C374	SMD capasitor X7R	10nF ñ10%	Murata	'
CG0103	C376	SMD capasitor X7R	10nF ñ10%	Murata	'
CH0105	C401	SMD capasitor	1uF/-20/+80%/16V	TaiyoYuden	EMK212 F105Z00T
CG0101	C402	SMD capasitor X7R	100pF ñ5%	Murata	
CG0223	C403	SMD capasitor X7R	22nF 20%	Murata	
CG0222	C404	SMD capasitor X7R	2.2nF ñ10%	Murata	
CG0100	C405	SMD capasitor NPO	10pF-+0.25pF	Murata	
CG0223	C406	SMD capasitor X7R	22nF 20%	Murata	
CG0223	C408	SMD capasitor X7R	22nF 20%	Murata	
CH0105	C409	SMD capasitor	1uF/-20/+80%/16V	TaiyoYuden	EMK212 F105Z00T
CH0105	C410	SMD capasitor	1uF/-20/+80%/16V	TaiyoYuden	EMK212 F105Z00T
CH0105	C411	SMD capasitor	1uF/-20/+80%/16V	TaiyoYuden	EMK212 F105Z00T
CF0473	C413	SMD capasitor	47 nF 10% 50 V X7R	Philips	
CG0223	C414	SMD capasitor X7R	22nF 20%	Murata	
CG0223	C415	SMD capasitor X7R	22nF 20%	Murata	
CG0223	C416	SMD capasitor X7R	22nF 20%	Murata	
CF0473	C417	SMD capasitor	47 nF 10% 50 V X7R	Philips	
CF0473	C418	SMD capasitor	47 nF 10% 50 V X7R	Philips	
CG0223	C419	SMD capasitor X7R	22nF 20%	Murata	
CG0223	C420	SMD capasitor X7R	22nF 20%	Murata	
CH0105	C421	SMD capasitor	1uF/-20/+80%/16V	TaiyoYuden	EMK212 F105Z00T
CD0104	C422	SMD capasitor	100 nF 10% 50 V X7R	Philips	
CD0104	C423	SMD capasitor	100 nF 10% 50 V X7R	Philips	
CH0105	C431	SMD capasitor	1uF/-20/+80%/16V	TaiyoYuden	EMK212 F105Z00T
CF0473	C432	SMD capasitor	47 nF 10% 50 V X7R	Philips	
CG0223	C433	SMD capasitor X7R	22nF 20%	Murata	
CG0471	C436	SMD capasitor X7R	470pF ñ10%	Murata	
CH0105	C437	SMD capasitor	1uF/-20/+80%/16V	TaiyoYuden	EMK212 F105Z00T
CG0101	C438	SMD capasitor X7R	100pF ñ5%	Murata	
CG0103	C439	SMD capasitor X7R	10nF ñ10%	Murata	'
DY0014	D101	SMD diode	1,5A/40V	Shindengen	D1FS4A
DS1056	D102	SMD diode pair	70V/100mA common anode	Philips	BAW 56W
DZ3339	D103	SMD zener	3V3 5% 500mW	Temic	BZM55C3V3 TR3
DY0054	D211	Shottky diode		Philips	BAT 54
DS1070	D213	SMD diode pair	70V/100mA common cathode	Philips	BAV 70W
DS1070	D214	SMD diode pair	70V/100mA common cathode	Philips	BAV 70W
DS1070	D215	SMD diode pair	70V/100mA common cathode	Philips	BAV 70W
DS1070	D216	SMD diode pair	70V/100mA common cathode	Philips	BAV 70W
DLG190	D221	SMD led green	20mcd/20mA	Citizen	CL-190G
DLG190	D222	SMD led green	20mcd/20mA	Citizen	CL-190G
DLG190	D225	SMD led green	20mcd/20mA	Citizen	CL-190G
DLG190	D226	SMD led green	20mcd/20mA	Citizen	CL-190G
DLG190	D227	SMD led green	20mcd/20mA	Citizen	CL-190G
DLG190	D228	SMD led green	20mcd/20mA	Citizen	CL-190G
DLG190	D229	SMD led green	20mcd/20mA	Citizen	CL-190G
DLG190	D230	SMD led green	20mcd/20mA	Citizen	CL-190G
DLG190	D231	SMD led green	20mcd/20mA	Citizen	CL-190G
DLG190	D233	SMD led green	20mcd/20mA	Citizen	CL-190G
DLG190	D234	SMD led green	20mcd/20mA	Citizen	CL-190G
DLG190	D235	SMD led green	20mcd/20mA	Citizen	CL-190G

CODE	PART	DESCRIPT.	VALUE	MANUF.	TYPE
DLG190	D236	SMD led green	20mcd/20mA	Citizen	CL-190G
DLG190	D237	SMD led green	20mcd/20mA	Citizen	CL-190G
DLG190	D238	SMD led green	20mcd/20mA	Citizen	CL-190G
DLG190	D239	SMD led green	20mcd/20mA	Citizen	CL-190G
DLG190	D240	SMD led green	20mcd/20mA	Citizen	CL-190G
DLG190	D241	SMD led green	20mcd/20mA	Citizen	CL-190G
DLG190	D242	SMD led green	20mcd/20mA	Citizen	CL-190G
DLG190	D243	SMD led green	20mcd/20mA	Citizen	CL-190G
DLG190	D244	SMD led green	20mcd/20mA	Citizen	CL-190G
DLG190	D245	SMD led green	20mcd/20mA	Citizen	CL-190G
DLG190	D246	SMD led green	20mcd/20mA	Citizen	CL-190G
DLG190	D247	SMD led green	20mcd/20mA	Citizen	CL-190G
DLG190	D248	SMD led green	20mcd/20mA	Citizen	CL-190G
DS1070	D301	SMD diode pair	70V/100mA common cathode	Philips	BAV 70W
DY0062	D401	SMD shcottky diode	40V 20mA	Siemens	BAT 62
DS1070	D403	SMD diode pair	70V/100mA common cathode	Philips	BAV 70W
AF1005	F101	SMD PTC Fuse	0.5A	Raychem	miniSMD050-2
AF4300	F102	SMD fuse	3A	Littlefuse	0430003.WR
IA0471	I101	Current sense ampl.		MAXIM	MAX471ESA-T
IR5205	I201	Voltage regulator	3.3V/1%/50mA	Micrel	LP2982IM5-3.3
IR7333	I202	Regulator with delay	3,3V/1.2A	Texas Inst	TPS7333QDR
IA7550	I301	Single op.amp.		Toshiba	TA 75S01F-TE85L
IG3010	I302	Digital-Asic		Hitachi	HG71C
IM4013	I303	Flash memory	4Mb/150ns/3.3V	AMD	AM29LV004B-150I
IG2048	I305	SIS ASIC		Atmel	
IX2339	I401	Audio processor	CMOS base band pros	AsahiKasei	AK2339
IC0454	I402	SMD 2x multip./demultip.		Toshiba	TC4W53FU-TE 12L
LF0062	L101	SMD EMI filter	10nF/2A	Panasonic	ELKE103FA
LF0062	L102	SMD EMI filter	10nF/2A	Panasonic	ELKE103FA
LC3334	L103	SMD inductor	330nH +-10%	TDK	MLF1608DR33K
QS1857	Q101	piensignaali yleistransi	PNP 100mA/45V hfe=220...470	Philips	BC857BW
QS1847	Q102	piensignaali yleistransi	NPN 100mA/45V hfe=200...450	Philips	BC847BW
QS1847	Q203	piensignaali yleistransi	NPN 100mA/45V hfe=200...450	Philips	BC847BW
QF0138	Q204	N-channel fet	50V/0,2A	Motorola	BSS138LT1
QS1857	Q205	piensignaali yleistransi	PNP 100mA/45V hfe=220...470	Philips	BC857BW
QS1847	Q206	piensignaali yleistransi	NPN 100mA/45V hfe=200...450	Philips	BC847BW
QS1857	Q301	piensignaali yleistransi	PNP 100mA/45V hfe=220...470	Philips	BC857BW
QS1847	Q302	piensignaali yleistransi	NPN 100mA/45V hfe=200...450	Philips	BC847BW
QS1847	Q303	piensignaali yleistransi	NPN 100mA/45V hfe=200...450	Philips	BC847BW
QS1847	Q304	piensignaali yleistransi	NPN 100mA/45V hfe=200...450	Philips	BC847BW
QF0138	Q403	N-channel fet	50V/0,2A	Motorola	BSS138LT1
RG0101	R101	SMD resistor	100R 5% 0.063W	Kamaya	RMC1/16S
RG0102	R102	SMD resistor	1k0 5% 0.063W	Kamaya	RMC1/16S
RG0101	R103	SMD resistor	100R 5% 0.063W	Kamaya	RMC1/16S
RG0101	R104	SMD resistor	100R 5% 0.063W	Kamaya	RMC1/16S
RG0470	R105	SMD resistor	47R 5% 0.063W	Kamaya	RMC1/16S
RG0101	R106	SMD resistor	100R 5% 0.063W	Kamaya	RMC1/16S
RG0101	R107	SMD resistor	100R 5% 0.063W	Kamaya	RMC1/16S
RG0101	R108	SMD resistor	100R 5% 0.063W	Kamaya	RMC1/16S
RG0102	R109	SMD resistor	1k0 5% 0.063W	Kamaya	RMC1/16S
RG0470	R110	SMD resistor	47R 5% 0.063W	Kamaya	RMC1/16S
RG0470	R111	SMD resistor	47R 5% 0.063W	Kamaya	RMC1/16S
RG0470	R112	SMD resistor	47R 5% 0.063W	Kamaya	RMC1/16S
RG0470	R113	SMD resistor	47R 5% 0.063W	Kamaya	RMC1/16S
RG0470	R114	SMD resistor	47R 5% 0.063W	Kamaya	RMC1/16S
RG0470	R115	SMD resistor	47R 5% 0.063W	Kamaya	RMC1/16S
RG0101	R116	SMD resistor	100R 5% 0.063W	Kamaya	RMC1/16S
RG0101	R117	SMD resistor	100R 5% 0.063W	Kamaya	RMC1/16S
RG0101	R118	SMD resistor	100R 5% 0.063W	Kamaya	RMC1/16S
RG0101	R119	SMD resistor	100R 5% 0.063W	Kamaya	RMC1/16S

CODE	PART	DESCRIPT.	VALUE	MANUF.	TYPE
RG0101	R120	SMD resistor	100R 5% 0.063W	Kamaya	RMC1/16S
RG0103	R121	SMD resistor	10k 5% 0.063W	Kamaya	RMC1/16S
RG0101	R122	SMD resistor	100R 5% 0.063W	Kamaya	RMC1/16S
RG0101	R123	SMD resistor	100R 5% 0.063W	Kamaya	RMC1/16S
RG0103	R124	SMD resistor	10k 5% 0.063W	Kamaya	RMC1/16S
RG0103	R125	SMD resistor	10k 5% 0.063W	Kamaya	RMC1/16S
RG0472	R126	SMD resistor	4k7 5% 0.063W	Kamaya	RMC1/16S
RG0472	R127	SMD resistor	4k7 5% 0.063W	Kamaya	RMC1/16S
RG0103	R128	SMD resistor	10k 5% 0.063W	Kamaya	RMC1/16S
RG0104	R129	SMD resistor	100k 5% 0.063W	Kamaya	RMC1/16S
RG0104	R130	SMD resistor	100k 5% 0.063W	Kamaya	RMC1/16S
RG0104	R131	SMD resistor	100k 5% 0.063W	Kamaya	RMC1/16S
RG0103	R132	SMD resistor	10k 5% 0.063W	Kamaya	RMC1/16S
RG0101	R133	SMD resistor	100R 5% 0.063W	Kamaya	RMC1/16S
RG0105	R134	SMD resistor	1M0 5% 0.063W	Kamaya	RMC1/16S
RG0103	R135	SMD resistor	10k 5% 0.063W	Kamaya	RMC1/16S
RG0222	R140	SMD resistor	2k2 5% 0.063W	Kamaya	RMC1/16S
RG0392	R141	SMD resistor	3k9 5% 0.063W	Kamaya	RMC1/16S
RG0104	R142	SMD resistor	100k 5% 0.063W	Kamaya	RMC1/16S
RG0471	R143	SMD resistor	470R 5% 0.063W	Kamaya	RMC1/16S
RG0471	R144	SMD resistor	470R 5% 0.063W	Kamaya	RMC1/16S
RG0102	R145	SMD resistor	1k0 5% 0.063W	Kamaya	RMC1/16S
RG0102	R146	SMD resistor	1k0 5% 0.063W	Kamaya	RMC1/16S
RG0102	R147	SMD resistor	1k0 5% 0.063W	Kamaya	RMC1/16S
RG0102	R151	SMD resistor	1k0 5% 0.063W	Kamaya	RMC1/16S
RG0102	R152	SMD resistor	1k0 5% 0.063W	Kamaya	RMC1/16S
RG0102	R153	SMD resistor	1k0 5% 0.063W	Kamaya	RMC1/16S
RG0102	R154	SMD resistor	1k0 5% 0.063W	Kamaya	RMC1/16S
RG0102	R155	SMD resistor	1k0 5% 0.063W	Kamaya	RMC1/16S
RG0102	R156	SMD resistor	1k0 5% 0.063W	Kamaya	RMC1/16S
RG0101	R158	SMD resistor	100R 5% 0.063W	Kamaya	RMC1/16S
RG0102	R159	SMD resistor	1k0 5% 0.063W	Kamaya	RMC1/16S
RG0102	R160	SMD resistor	1k0 5% 0.063W	Kamaya	RMC1/16S
RG0102	R161	SMD resistor	1k0 5% 0.063W	Kamaya	RMC1/16S
RG0102	R162	SMD resistor	1k0 5% 0.063W	Kamaya	RMC1/16S
RG0101	R163	SMD resistor	100R 5% 0.063W	Kamaya	RMC1/16S
RG0101	R164	SMD resistor	100R 5% 0.063W	Kamaya	RMC1/16S
RG0101	R165	SMD resistor	100R 5% 0.063W	Kamaya	RMC1/16S
RG0101	R166	SMD resistor	100R 5% 0.063W	Kamaya	RMC1/16S
RG0101	R167	SMD resistor	100R 5% 0.063W	Kamaya	RMC1/16S
RG0103	R171	SMD resistor	10k 5% 0.063W	Kamaya	RMC1/16S
RG0103	R172	SMD resistor	10k 5% 0.063W	Kamaya	RMC1/16S
RG0100	R201	SMD resistor	10 R 5% 0.063W	Kamaya	RMC1/16S
RG0101	R202	SMD resistor	100R 5% 0.063W	Kamaya	RMC1/16S
RG0102	R203	SMD resistor	1k0 5% 0.063W	Kamaya	RMC1/16S
RG0102	R204	SMD resistor	1k0 5% 0.063W	Kamaya	RMC1/16S
RG0100	R207	SMD resistor	10 R 5% 0.063W	Kamaya	RMC1/16S
RG0102	R208	SMD resistor	1k0 5% 0.063W	Kamaya	RMC1/16S
RG0274	R209	SMD resistor	270k 5% 0.063W	Kamaya	RMC1/16S
RG0334	R210	SMD resistor	330k 5% 0.063W	Kamaya	RMC1/16S
RG0101	R212	SMD resistor	100R 5% 0.063W	Kamaya	RMC1/16S
RG0274	R214	SMD resistor	270k 5% 0.063W	Kamaya	RMC1/16S
RG0274	R215	SMD resistor	270k 5% 0.063W	Kamaya	RMC1/16S
RG0473	R216	SMD resistor	47k 5% 0.063W	Kamaya	RMC1/16S
RG0103	R217	SMD resistor	10k 5% 0.063W	Kamaya	RMC1/16S
RG0392	R218	SMD resistor	3k9 5% 0.063W	Kamaya	RMC1/16S
RG0473	R219	SMD resistor	47k 5% 0.063W	Kamaya	RMC1/16S
RG0104	R220	SMD resistor	100k 5% 0.063W	Kamaya	RMC1/16S
RG0223	R221	SMD resistor	22k 5% 0.063W	Kamaya	RMC1/16S
RG0105	R222	SMD resistor	1M0 5% 0.063W	Kamaya	RMC1/16S

CODE	PART	DESCRIPT.	VALUE	MANUF.	TYPE
RG0224	R223	SMD resistor	220k 5% 0.063W	Kamaya	RMC1/16S
RG0103	R225	SMD resistor	10k 5% 0.063W	Kamaya	RMC1/16S
RG0105	R226	SMD resistor	1M0 5% 0.063W	Kamaya	RMC1/16S
RG0222	R232	SMD resistor	2k2 5% 0.063W	Kamaya	RMC1/16S
RG0222	R233	SMD resistor	2k2 5% 0.063W	Kamaya	RMC1/16S
RG0222	R234	SMD resistor	2k2 5% 0.063W	Kamaya	RMC1/16S
RG0222	R235	SMD resistor	2k2 5% 0.063W	Kamaya	RMC1/16S
RG0222	R236	SMD resistor	2k2 5% 0.063W	Kamaya	RMC1/16S
RG0102	R237	SMD resistor	1k0 5% 0.063W	Kamaya	RMC1/16S
RG0222	R238	SMD resistor	2k2 5% 0.063W	Kamaya	RMC1/16S
RG0222	R239	SMD resistor	2k2 5% 0.063W	Kamaya	RMC1/16S
RG0222	R240	SMD resistor	2k2 5% 0.063W	Kamaya	RMC1/16S
RG0103	R241	SMD resistor	10k 5% 0.063W	Kamaya	RMC1/16S
RG0103	R242	SMD resistor	10k 5% 0.063W	Kamaya	RMC1/16S
RG0221	R244	SMD resistor	220R 5% 0.063W	Kamaya	RMC1/16S
RG0221	R245	SMD resistor	220R 5% 0.063W	Kamaya	RMC1/16S
RG0221	R246	SMD resistor	220R 5% 0.063W	Kamaya	RMC1/16S
RG0221	R247	SMD resistor	220R 5% 0.063W	Kamaya	RMC1/16S
RG0104	R301	SMD resistor	100k 5% 0.063W	Kamaya	RMC1/16S
RG0104	R302	SMD resistor	100k 5% 0.063W	Kamaya	RMC1/16S
RG0274	R303	SMD resistor	270k 5% 0.063W	Kamaya	RMC1/16S
RG0104	R304	SMD resistor	100k 5% 0.063W	Kamaya	RMC1/16S
RG0683	R305	SMD resistor	68k 5% 0.063W	Kamaya	RMC1/16S
RG0103	R306	SMD resistor	10k 5% 0.063W	Kamaya	RMC1/16S
RG0104	R307	SMD resistor	100k 5% 0.063W	Kamaya	RMC1/16S
RG0104	R308	SMD resistor	100k 5% 0.063W	Kamaya	RMC1/16S
RG0104	R309	SMD resistor	100k 5% 0.063W	Kamaya	RMC1/16S
RG0102	R310	SMD resistor	1k0 5% 0.063W	Kamaya	RMC1/16S
RG0103	R311	SMD resistor	10k 5% 0.063W	Kamaya	RMC1/16S
RG0103	R312	SMD resistor	10k 5% 0.063W	Kamaya	RMC1/16S
RG0105	R315	SMD resistor	1M0 5% 0.063W	Kamaya	RMC1/16S
RF0106	R316	SMD resistor	10 M 5% 0.125 W	Kamaya	RMC1/16S
RG0101	R321	SMD resistor	100R 5% 0.063W	Kamaya	RMC1/16S
RG0224	R322	SMD resistor	220k 5% 0.063W	Kamaya	RMC1/16S
RTN154	R323	SMD NTC-resistor	150k 5% B=4100	Hokuriku	157-154-45001TP
RG0392	R324	SMD resistor	3k9 5% 0.063W	Kamaya	RMC1/16S
RG0224	R325	SMD resistor	220k 5% 0.063W	Kamaya	RMC1/16S
RG0104	R326	SMD resistor	100k 5% 0.063W	Kamaya	RMC1/16S
RG0104	R327	SMD resistor	100k 5% 0.063W	Kamaya	RMC1/16S
RG0105	R328	SMD resistor	1M0 5% 0.063W	Kamaya	RMC1/16S
RG0105	R329	SMD resistor	1M0 5% 0.063W	Kamaya	RMC1/16S
RG0473	R330	SMD resistor	47k 5% 0.063W	Kamaya	RMC1/16S
RG0000	R331	SMD resistor	0 ohm		
RG0103	R341	SMD resistor	10k 5% 0.063W	Kamaya	RMC1/16S
RG0103	R342	SMD resistor	10k 5% 0.063W	Kamaya	RMC1/16S
RG0103	R343	SMD resistor	10k 5% 0.063W	Kamaya	RMC1/16S
RG0103	R344	SMD resistor	10k 5% 0.063W	Kamaya	RMC1/16S
RG0104	R351	SMD resistor	100k 5% 0.063W	Kamaya	RMC1/16S
RG0104	R352	SMD resistor	100k 5% 0.063W	Kamaya	RMC1/16S
RG0104	R353	SMD resistor	100k 5% 0.063W	Kamaya	RMC1/16S
RG0104	R354	SMD resistor	100k 5% 0.063W	Kamaya	RMC1/16S
RG0104	R355	SMD resistor	100k 5% 0.063W	Kamaya	RMC1/16S
RG0104	R356	SMD resistor	100k 5% 0.063W	Kamaya	RMC1/16S
RG0104	R357	SMD resistor	100k 5% 0.063W	Kamaya	RMC1/16S
RG0100	R361	SMD resistor	10 R 5% 0.063W	Kamaya	RMC1/16S
RG0100	R362	SMD resistor	10 R 5% 0.063W	Kamaya	RMC1/16S
RG0102	R363	SMD resistor	1k0 5% 0.063W	Kamaya	RMC1/16S
RG0102	R364	SMD resistor	1k0 5% 0.063W	Kamaya	RMC1/16S
RG0102	R365	SMD resistor	1k0 5% 0.063W	Kamaya	RMC1/16S
RG0102	R366	SMD resistor	1k0 5% 0.063W	Kamaya	RMC1/16S

CODE	PART	DESCRIPT.	VALUE	MANUF.	TYPE
RG0102	R367	SMD resistor	1k0 5% 0.063W	Kamaya	RMC1/16S
RG0102	R368	SMD resistor	1k0 5% 0.063W	Kamaya	RMC1/16S
RG0102	R369	SMD resistor	1k0 5% 0.063W	Kamaya	RMC1/16S
RG0392	R371	SMD resistor	3k9 5% 0.063W	Kamaya	RMC1/16S
RG0104	R372	SMD resistor	100k 5% 0.063W	Kamaya	RMC1/16S
RG0122	R373	SMD resistor	1k2 5% 0.063W	Kamaya	RMC1/16S
RG0183	R374	SMD resistor	18k 5% 0.063W	Kamaya	RMC1/16S
RG0471	R375	SMD resistor	470R 5% 0.063W	Kamaya	RMC1/16S
RG0103	R376	SMD resistor	10k 5% 0.063W	Kamaya	RMC1/16S
RG0102	R401	SMD resistor	1k0 5% 0.063W	Kamaya	RMC1/16S
RG0222	R402	SMD resistor	2k2 5% 0.063W	Kamaya	RMC1/16S
RG0153	R403	SMD resistor	15k 5% 0.063W	Kamaya	RMC1/16S
RG0105	R404	SMD resistor	1M0 5% 0.063W	Kamaya	RMC1/16S
RG0153	R405	SMD resistor	15k 5% 0.063W	Kamaya	RMC1/16S
RG0000	R406	SMD resistor	0 ohm		
RG0683	R408	SMD resistor	68k 5% 0.063W	Kamaya	RMC1/16S
RG0563	R415	SMD resistor	56k 5% 0.063W	Kamaya	RMC1/16S
RG0104	R417	SMD resistor	100k 5% 0.063W	Kamaya	RMC1/16S
RG0104	R418	SMD resistor	100k 5% 0.063W	Kamaya	RMC1/16S
RG0103	R430	SMD resistor	10k 5% 0.063W	Kamaya	RMC1/16S
RG0563	R431	SMD resistor	56k 5% 0.063W	Kamaya	RMC1/16S
RG0563	R432	SMD resistor	56k 5% 0.063W	Kamaya	RMC1/16S
RG0563	R433	SMD resistor	56k 5% 0.063W	Kamaya	RMC1/16S
RG0000	R440	SMD resistor	0 ohm		
RG0103	R442	SMD resistor	10k 5% 0.063W	Kamaya	RMC1/16S
RG0563	R443	SMD resistor	56k 5% 0.063W	Kamaya	RMC1/16S
RG0223	R444	SMD resistor	22k 5% 0.063W	Kamaya	RMC1/16S
RG0393	R445	SMD resistor	39k 5% 0.063W	Kamaya	RMC1/16S
AS0260	S201	Keyboard module	PE-laminate	Screenotec	
VM0342	V101	SMD system connector	16 pin	AMP	338269-1
VW0107	V102	Power connector	male 4-pin	Elco	58-9155-004-000-
VN0019	V103	SMD B/B-connector 3mm	20 pin	Matsushita	AXN420330P
VM0005	V104	Terminal srtp	5 pin	Samtec	ASP-61841-02-M
X48007	X301	SMD crystal	4,8MHz CL=16pF 30ppm	Citezen	CS 20
X32766	X302	SMD crystal	32.768kHz +-30ppm	MicroCryst	MS1V-TK
PA1900	Y5	PCB for OA1900			

Last
update
11.10.99

The Top Side Layout PA1900 A3

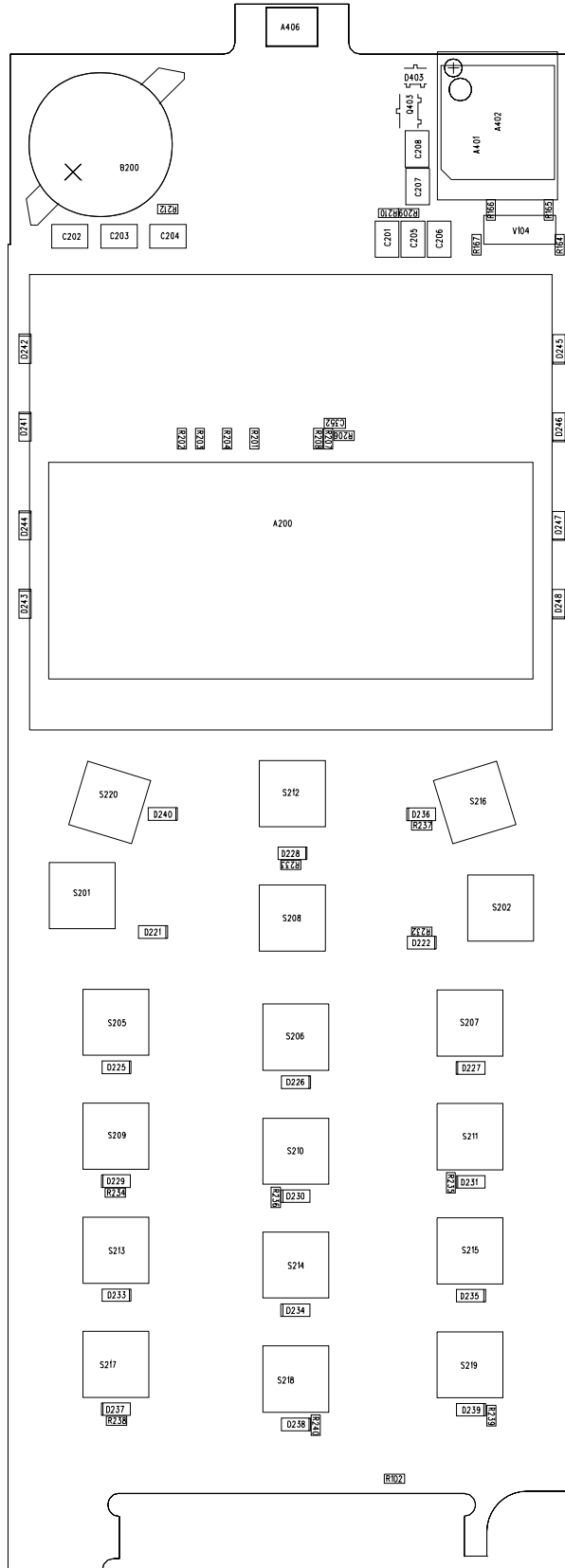

PA1900A3 913

The Bottom Side Layout PA1900 A3

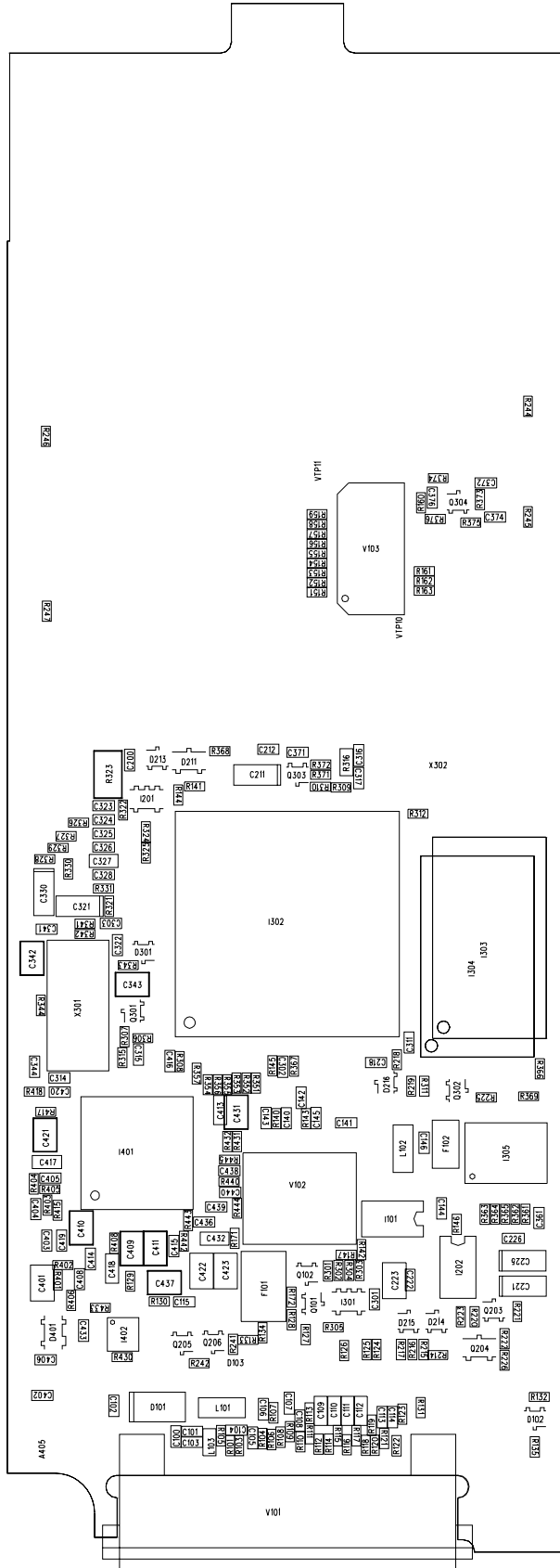

PA1900A3 013

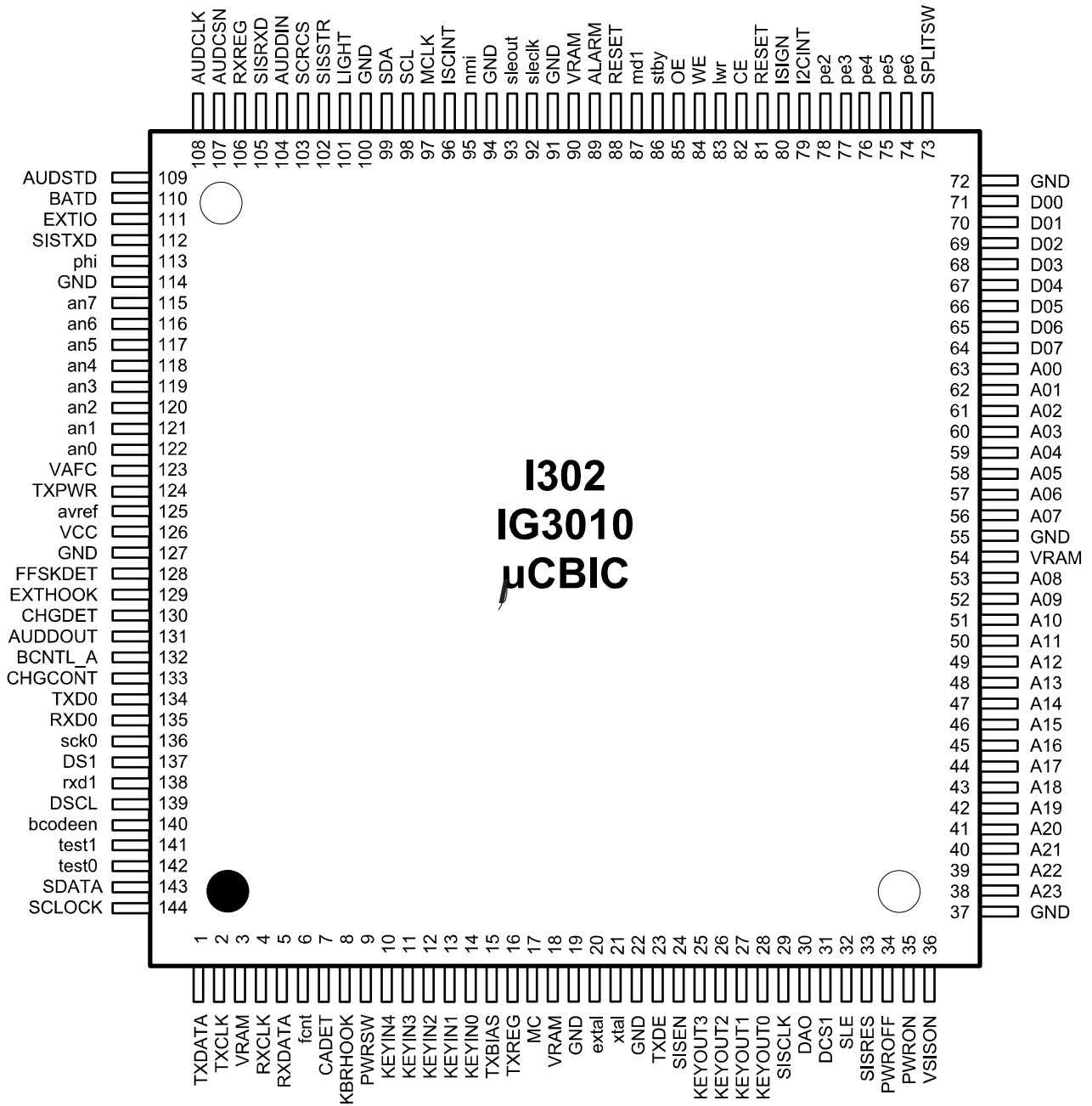

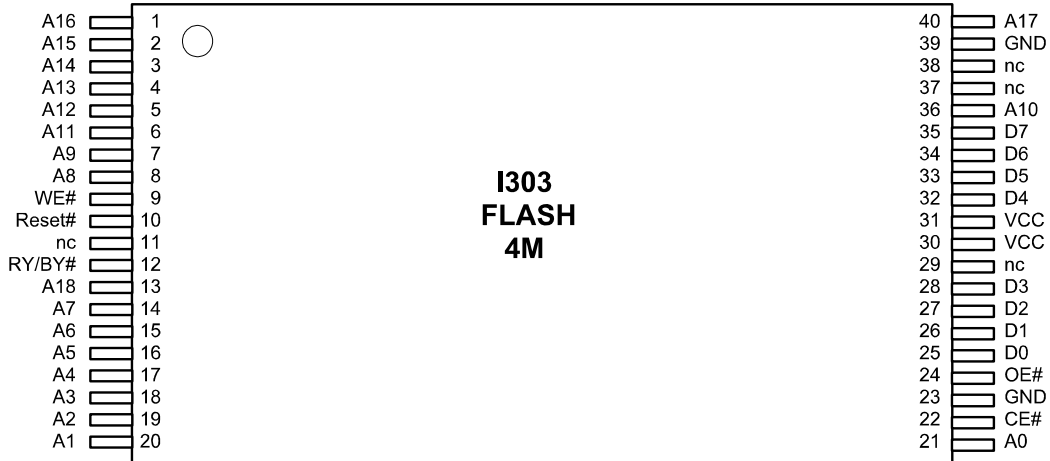

Standard 40-pin TSOP

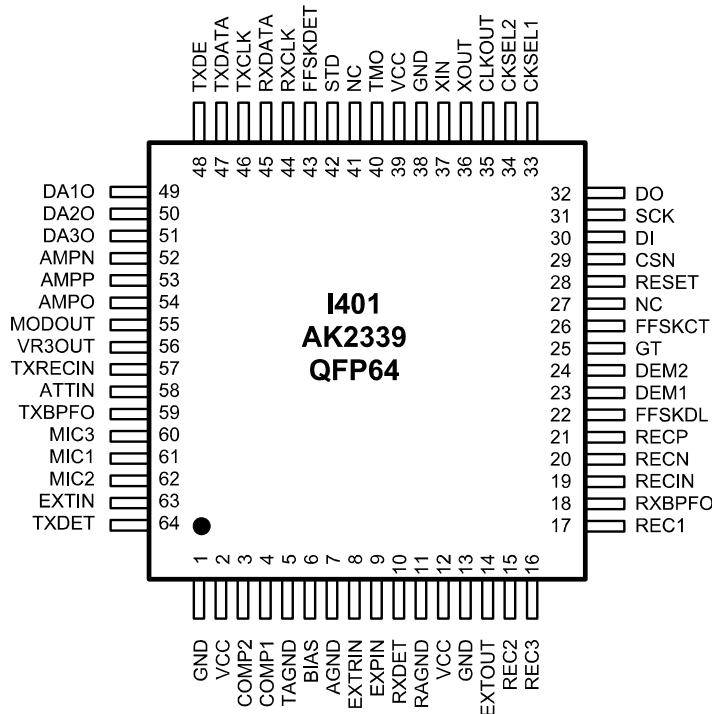
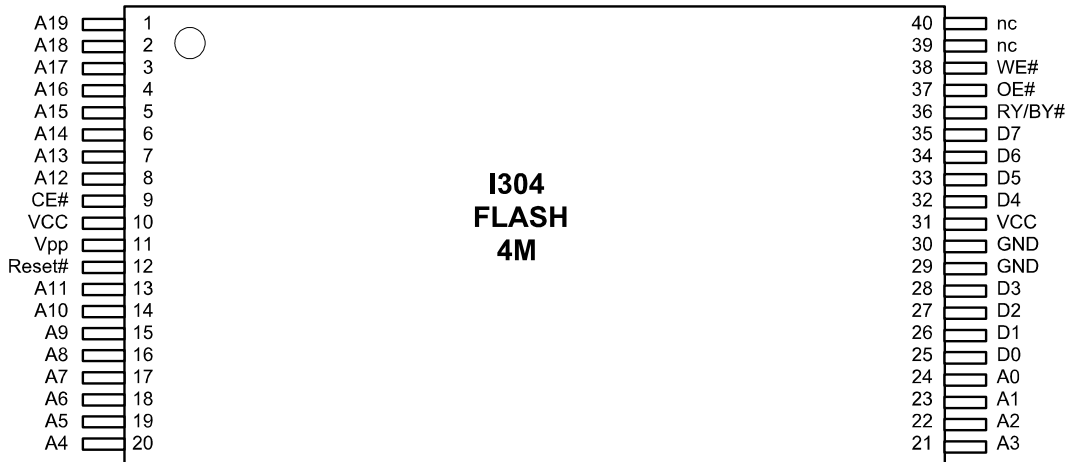

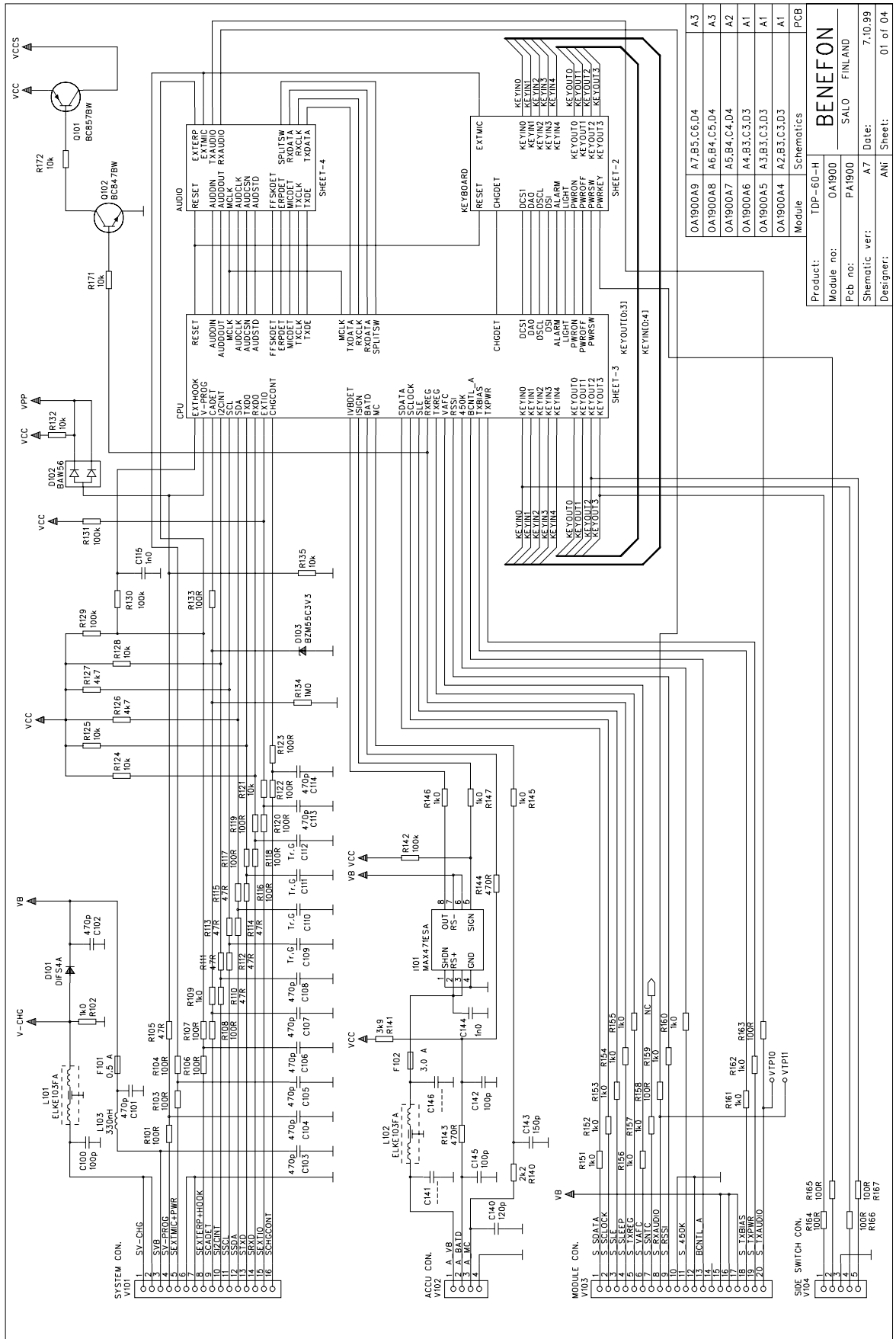

0A1900A9	A7.B5.C6.D4	A3
0A1900A8	A6.B4.C5.D4	A3
0A1900A7	A5.B4.C4.D4	A2
0A1900A6	A4.B3.C3.D3	A1
0A1900A5	A3.B3.C3.D3	A1
0A1900A4	A2.B3.C3.D3	A1
Module	Schematics	PCB

Product:	TDP-60-H
Module no:	OA1900
Pcb no:	PA1900
Schematic ver:	A7 Dcte: 7.10.99
Designer:	Ani Sheet: 01 of 04

BENEFON	
SALO	FINLAND

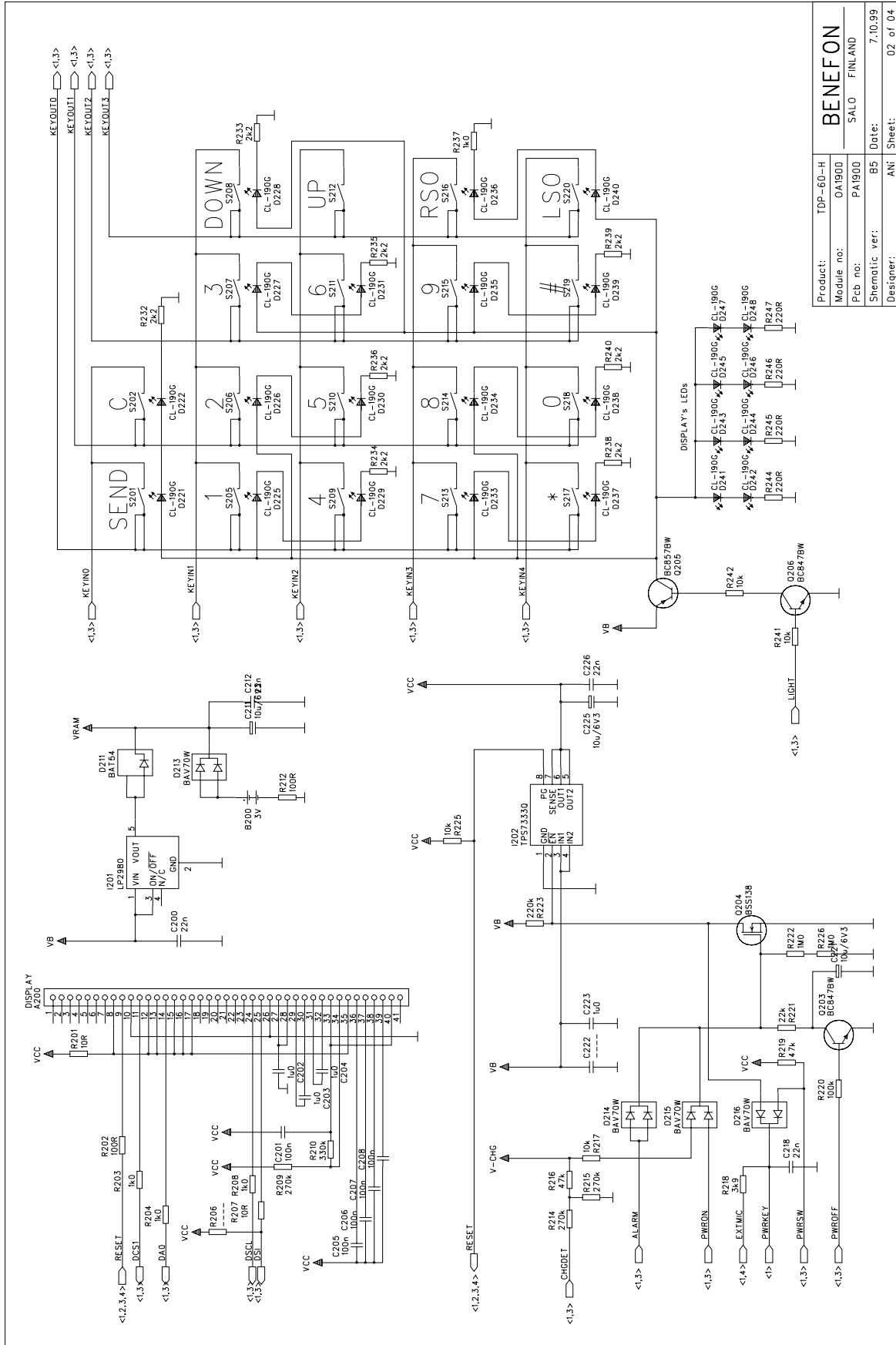

Product:	TDP-60-H	BENEFON
Module no:	OA1900	
Pcb no:	PA1900	SALO FINLAND
Schematic ver:	B5	Date: 7.10.99
Designer:	AN	Sheet: 02 of 04

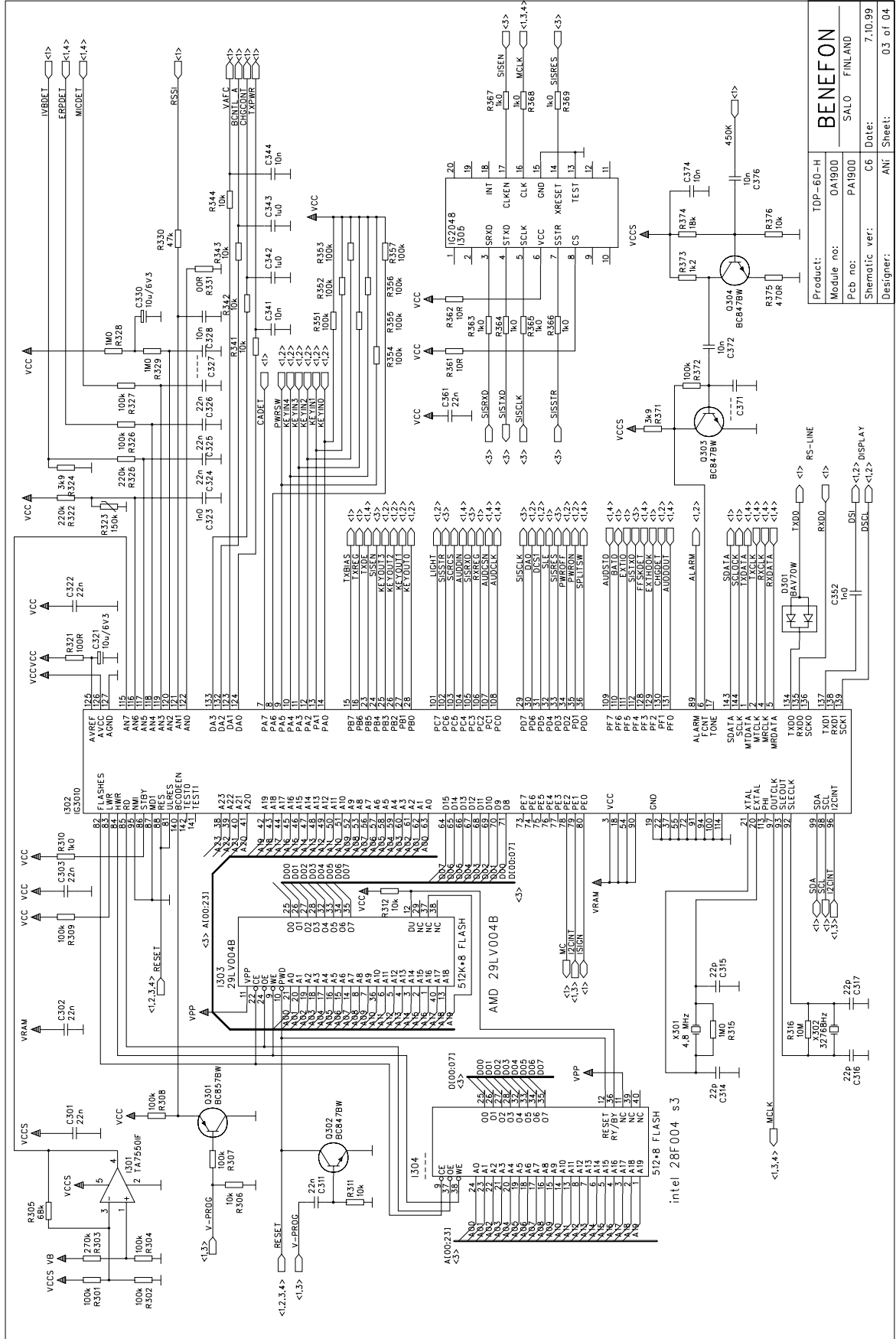

Product:	TDP-60-H
Module no:	OA1900
Pcb no:	PA1900
Shematic ver:	C6
Designer:	ANI
Date:	7.10.99
Sheet:	03 of 04

Product:	TDP-60-H
Module no:	OA1900
Pcb no:	PA1900
Shematic ver:	C6
Designer:	ANI
Date:	7.10.99
Sheet:	03 of 04

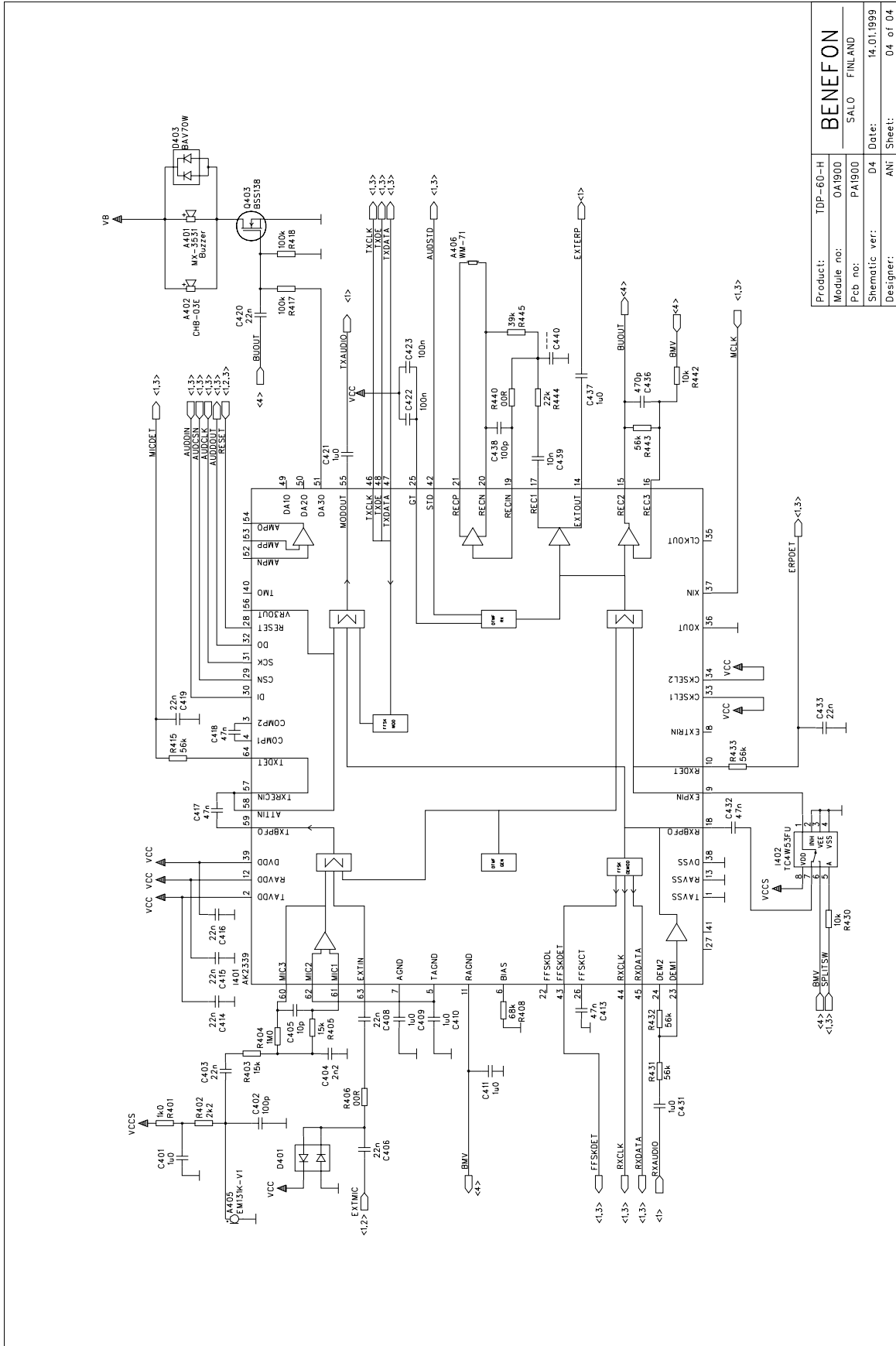

Product:	TDP-60-H
Module no:	OA1900
Pcb no:	PA1900
Schematic ver.:	D4
Designer:	ANI
Date:	14.01.1999
Sheet:	04 of 04

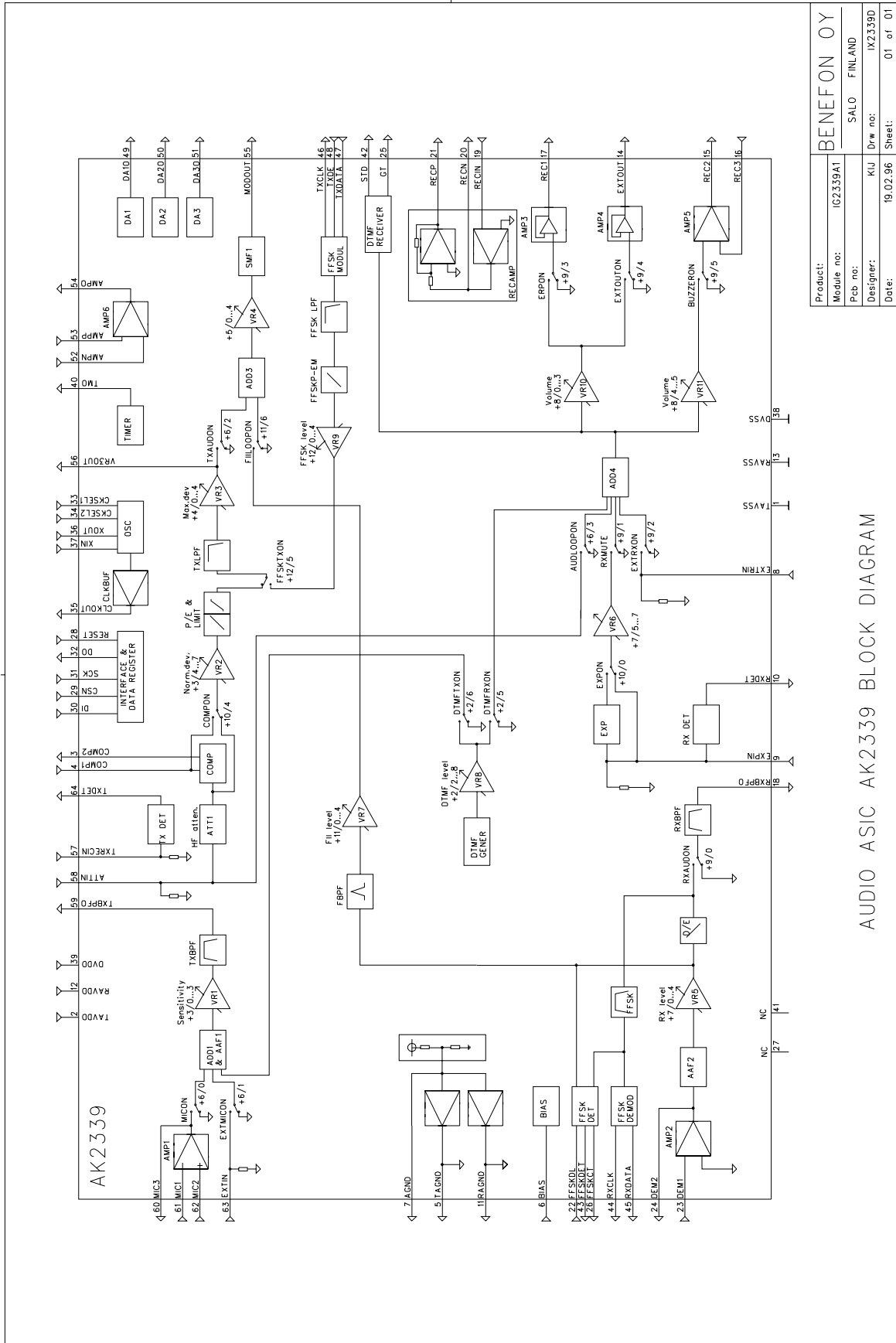

Product:	BENEFON OY
Module no.:	IG2339AT
Pcb no.:	SALO FINLAND
Designer:	KJJ
Date:	19.02.96
Sheet:	01 of 01

AUDIO ASIC AK2339 BLOCK DIAGRAM

5.2 RF MODULE

RX Synthesizer

OY1920 Synthesizer

5.2.1 General

The RX synthesizer generates an upper side injection frequency for the receiver. The injection frequency is fed to the receiver's first mixer.

Operating voltage	3.8 VDC
Current consumption	14 mA
Output level to the receiver	+1 dBm
Frequency range	540,550...545,025 MHz

5.2.2 Functional Description

The RX injection frequency is generated with a phase locked loop. The VCO produces the injection frequency determined by the control voltage. After the VCO stage comes the amplifier stage Q320. After the amplifier stage, part of the signal is fed to the synthesizer circuits I300 divider. The synthesizer circuit contains a pre-scaler, programmable divider, reference frequency divider, and a phase detector.

The synthesizer circuit produces current pulses at output DO1 as controlled by the phase detector. The current pulses either charge or discharge the loop filter. The VCO control voltage is derived from the loop filter output.

The synthesizer 12.5 kHz reference frequency is made by dividing the 12.85 MHz signal from the temperature compensated oscillator (TCXO). The series-form signal which controls the channel frequency comes from the audio/processor-module via connector V600. SDATA, SCLK and SLE signals are common to both TX- and RX-synthesizers. A positive pulse in the SLE line loads the division ratio (corresponding to the frequency of the channel) fed to the SDATA line, to the synthesizer circuit I300.

5.2.3 Control- and Output-Signals

VRX	RX synthesizer operating voltage	3.8 V
SCLK	Clock signal for the synthesizer control data	
SDATA	Synthesizer control data	
SLE	ENABLE pulse to the synthesizer	
RXINJ	RX synthesizer output to the receiver	+1 dBm
RX_REG	Control line for VRX-regulator	

TX-Synthesizer

5.2.4 General

The TX synthesizer generates the final modulated transmission frequency, which is fed to the transmitter.

Operating voltage	3.8 VDC
Current consumption	<30 mA
Output level to the transmitter	+6 dBm
Frequency range	453.000...457.475 MHz

5.2.5 Function Description

The TX frequency is generated with a phase locked loop (PLL). The VCO produces the injection frequency determined by the control voltage, and the VCO also has a modulation input. After the VCO stage come two amplifier stages Q420 and Q430. These ensure separation between the VCO and transmitter, and also boost the injection level sufficiently. Part of the signal is fed from between the amplifier stages to the synthesizer circuit I300 pre-scaler input Fin2. The synthesizer circuit contains a pre-scaler, programmable divider, reference frequency divider, and a phase detector.

The synthesizer circuit produces current pulses at output DO2 as a result of the phase detection. The current pulses either charge or discharge the loop filter condensators. The VCO control voltage is derived from the loop filter output.

The synthesizer 2.5 kHz reference frequency is made by dividing the 12.85 MHz signal from the temperature compensated oscillator (TCXO). The series-form signal which controls the channel frequency comes from the audio/processor-modules via the V600 connector. SDATA and SCLK signals are common to both TX- and RX-synthesizers. A positive pulse in the SLE-line loads the division ratio (corresponding to the TX frequency of the channel) fed to the SDATA line, to the synthesizer circuit I300.

Modulation is fed to the TX synthesizer TX-AUDIO line. The frequency response is corrected by the components R463 - R465, C461 and C462. Modulation sensitivity is set by the resistor R460.

5.2.6 Control- and Output-Signals

VTXS	TX synthesizer operating voltage (3.8 V)
TXAUDIO	Transmitter audio signal
12M85	12.85 MHz signal to the receiver circuit.
SCLK	Clock signal for synthesizer control data
SDATA	Synthesizer control data
SLE	ENABLE pulse to the synthesizer
TXINJ	TX synthesizer output to the transmitter (+6 dBm)
AFC	AFC control voltage from AF/LOGIC-board
TXS_REG	Control line for VTXS-regulator

Receiver

OY1920 Receiver

5.2.7 General

The module contains all FM-receiver functional blocks.

RF-amplifier	3SK284
1. mixer	double-balanced mixer
1. IF-amplifier	3SK284
FM IF system	SA 607 includes the following blocks: 2. mixer IF limiter quadrature detector RSSI (received signal strength indicator)

When the RF signal is received it is brought through the duplex filter to the amplifier stage Q101. The amplified signal is passed through the attenuator to the double-balanced mixer X 102.

The upper side injection frequency is brought from the synthesizer through a small resistive attenuator to the mixer LO pin 1 (LO = local oscillator). The 77.55 MHz intermediate frequency from the mixer output is fed through the IF- filter X102 to the FM IF-circuit I201.

RX injection frequency 540,550...545,025 MHz

Injection-level/impedance +1 dBm / 50 ohm

The second intermediate-frequency local-oscillator-frequency required by the FM IF-circuit is generated by multiplying the 12.85 MHz reference-oscillator frequency by six. The multiplier circuit is made with transistor Q201.

The second intermediate frequency is 450 kHz. The phase-shift required by the quadrature detector is made with the parallel-circuit L203 and C226. The detected AF-signal temperature correction is done in the buffer amplifier stage.

5.2.8 Input- and Output-Signals

RF input from the duplex filter	463,000...467,475 MHz
RXINJ	RX injection signal to the double balanced mixer
12M85	12.85 MHz signal to the multiplier for the 2. mixer
VRX	RX operating voltage 3.8V from the regulator
450 kHz	Output from 2. IF to the AFC detector
RXAUDIO	Receiver audio output 100mVrms
RSSI	Received signal strength indicator output 0,5...2V

SENSITIVITY CHECK

channel	RF input	SINAD psf.
001	-113 dBm	≥20 dB
180	-113 dBm	≥20 dB

Transmitter

OY1920 Transmitter

5.2.9 General

Operating voltage	4.7 ... 6 v
Current consumption	mid power max. 1.0 A low power max. 0.45 A
Input level from the synthesizer	+6 dBm
Output level to the duplex filter	mid power 33 dBm (2.0W) low power 24.7 dBm (0.3W)
Frequency range	453,000...457,475 MHz

5.2.10 Function Description

The transmitter unit is comprised of three amplifier stages and two attenuator stages. The pre-amplifier Q600/Q605 and power module I600 form the transmitter amplifier chain. The attenuators surrounding the pre-amplifier are included to enhance the electric separation between the TX synthesizer and the transmitter. C650 enhances power module efficiency.

The operational amplifier I610 and transistors Q610 and Q620 serve as a power regulator circuit, which adjusts the power level so that the voltage from the transmitter power detector (D610) and the control voltage TXPWR from the audio/processor unit are equal. The power-module power-control voltage must not exceed 8 V.

The negative bias voltage for the power amplifier is generated from the 12.85 MHz TCXO signal.

I620 amplifies the signal for the switched power supply Q650/D630 and is then regulated by the zenerdiode D600 to -3.5 V.

I601 serves as voltage regulator for pre-amplifier and for the negative voltage generator.

Q660 serves as the ON/OFF switch for the output power.

When the phone is connected to an external voltage supply, the audio/processor unit raises the transmitter power by approx 1.0 dB using the TXPWR control.

5.2.11 Control- and Output-Signals

VBAT	Transmitter operating voltage from the battery-pack (fused)	
TXBIAS	Power ON/OFF control	
TXPWR	Power level control signal from the D/A converter	0...3V
TXINJ	RF signal from the TX synthesizer	+6dBm
TXDUPLEX	Transmitter output to the duplex filter	

PY1900

The Top Side Layout PY1900A0

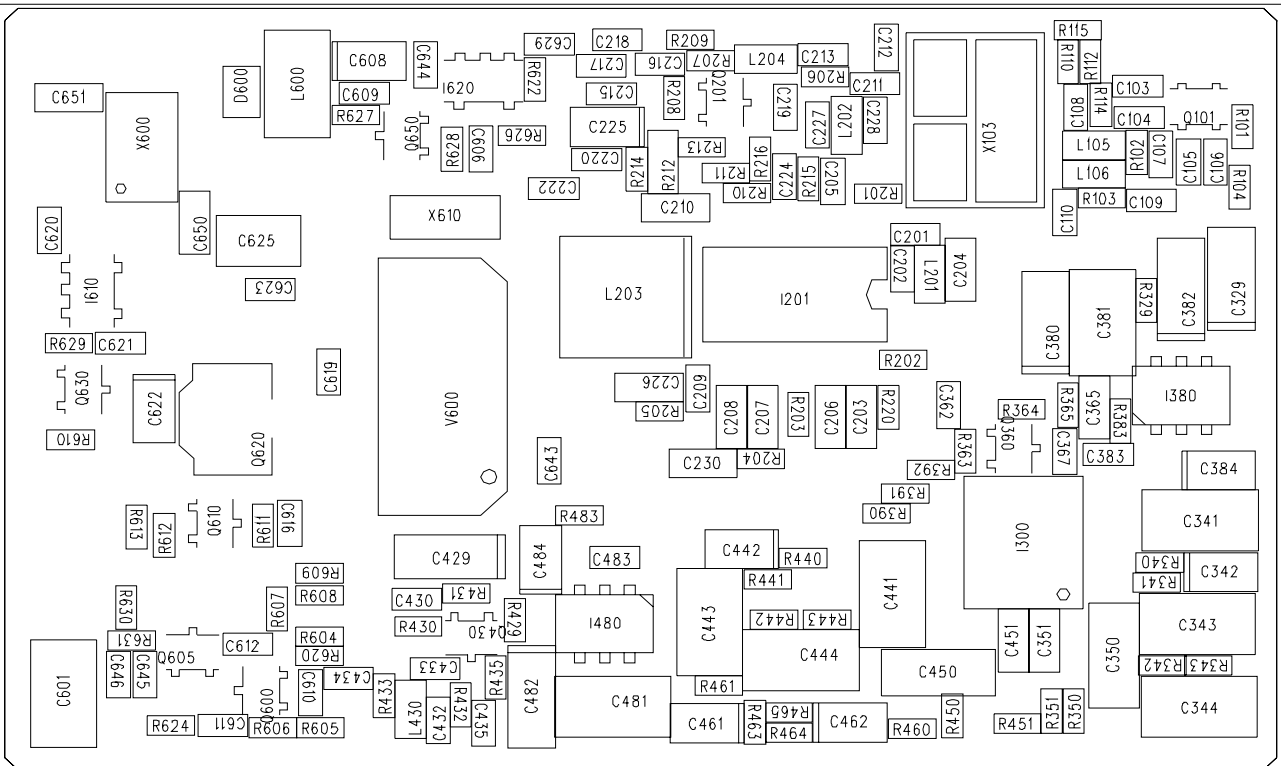
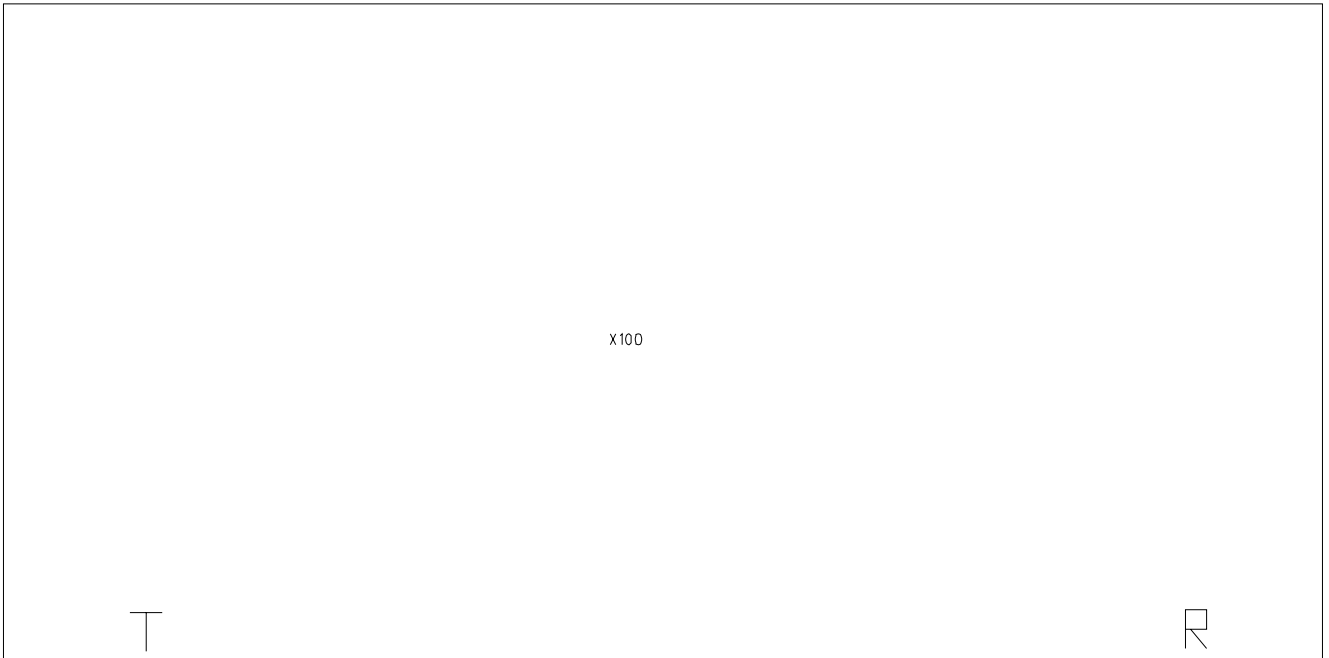

PY1900A0 810

The Bottom Side Layout PY1900A0

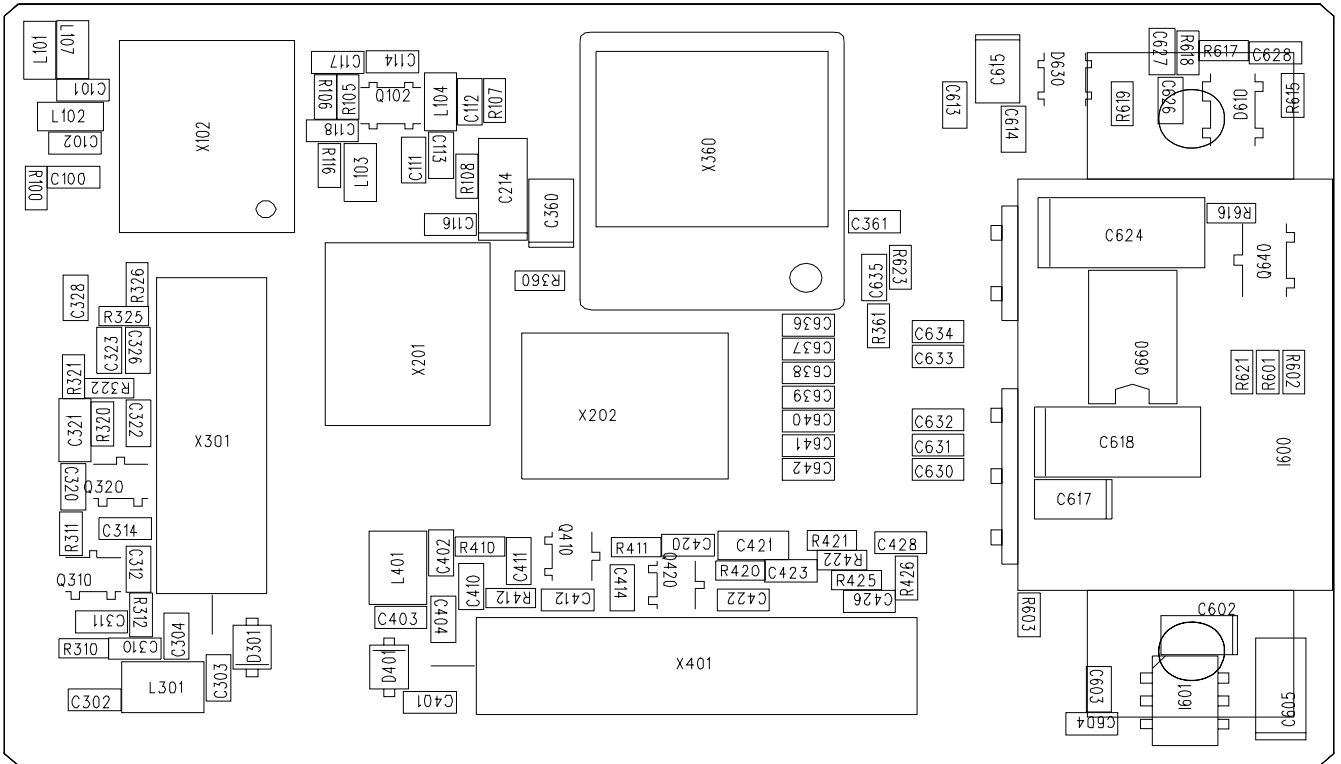

PY1900A0 810

5.2.12 Parts list OY1920

OY1920-RF

CODE	PART	DESCRIPT.	VALUE	MANUF.	TYPE
CG0102	C100	SMD capasitor X7R	1nF ñ10%	Murata	
CG0330	C101	SMD capasitor NPO	33pF ñ5%	Murata	
CG0569	C102	SMD capasitor NPO	5.6pF ñ0,25pF	Murata	
CG0101	C103	SMD capasitor X7R	100pF ñ5%	Murata	
CG0180	C104	SMD capasitor NPO	18pF ñ5%	Murata	
CG0101	C105	SMD capasitor X7R	100pF ñ5%	Murata	
CG0180	C106	SMD capasitor NPO	18pF ñ5%	Murata	
CG0339	C107	SMD capasitor NPO	3.3pF ñ0,25pF	Murata	
CG0101	C108	SMD capasitor X7R	100pF ñ5%	Murata	
CG0101	C109	SMD capasitor X7R	100pF ñ5%	Murata	
CG0101	C110	SMD capasitor X7R	100pF ñ5%	Murata	
CG0101	C111	SMD capasitor X7R	100pF ñ5%	Murata	
CG0829	C112	SMD capasitor NPO	8.2pF ñ0,25pF	Murata	
CG0102	C113	SMD capasitor X7R	1nF ñ10%	Murata	
CG0279	C114	SMD capasitor NPO	2.7pF ñ0,25pF	Murata	
CG0102	C116	SMD capasitor X7R	1nF ñ10%	Murata	
CG0103	C117	SMD capasitor X7R	10nF ñ10%	Murata	
CG0150	C118	SMD capasitor NPO	15pF ñ5%	Murata	
CG0339	C201	SMD capasitor NPO	3.3pF ñ0,25pF	Murata	
CG0569	C202	SMD capasitor NPO	5.6pF ñ0,25pF	Murata	
CF0223	C203	SMD capasitor	22 nF 10% 50 V X7R	Philips	
CF0223	C204	SMD capasitor	22 nF 10% 50 V X7R	Philips	
CG0399	C205	SMD capasitor NPO	3.9pF ñ0,25pF	Murata	
CF0223	C206	SMD capasitor	22 nF 10% 50 V X7R	Philips	
CF0223	C207	SMD capasitor	22 nF 10% 50 V X7R	Philips	
CF0223	C208	SMD capasitor	22 nF 10% 50 V X7R	Philips	
CG0100	C209	SMD capasitor NPO	10pF+0.25pF	Murata	
CF0223	C210	SMD capasitor	22 nF 10% 50 V X7R	Philips	
CG0103	C211	SMD capasitor X7R	10nF ñ10%	Murata	
CG0103	C212	SMD capasitor X7R	10nF ñ10%	Murata	
CG0102	C213	SMD capasitor X7R	1nF ñ10%	Murata	
CU3106	C214	SMD tantal	10uF / 6V +20%	AVX	TAJA106M006R
CG0102	C215	SMD capasitor X7R	1nF ñ10%	Murata	
CG0103	C216	SMD capasitor X7R	10nF ñ10%	Murata	
CG0150	C217	SMD capasitor NPO	15pF ñ5%	Murata	
CG0101	C218	SMD capasitor X7R	100pF ñ5%	Murata	
CG0150	C219	SMD capasitor NPO	15pF ñ5%	Murata	
CG0103	C220	SMD capasitor X7R	10nF ñ10%	Murata	
CG0103	C222	SMD capasitor X7R	10nF ñ10%	Murata	
CG0331	C224	SMD capasitor X7R	330pF ñ10%	Murata	
CU2105	C225	SMD tantal	1uF/10V	AVX	TAJR105M010R
CF3471	C226	SMD capasitor	470pF+-2% 50V NPO	AVX	CM105CG471G50AB
CG0399	C227	SMD capasitor NPO	3.9pF ñ0,25pF	Murata	
CG0390	C228	SMD capasitor NPO	39pF ñ5%	Murata	
CF0223	C230	SMD capasitor	22 nF 10% 50 V X7R	Philips	
CG0101	C302	SMD capasitor X7R	100pF ñ5%	Murata	
CG0150	C303	SMD capasitor NPO	15pF ñ5%	Murata	
CG0479	C310	SMD capasitor NPO	4.7pF ñ0,25pF	Murata	
CG0150	C311	SMD capasitor NPO	15pF ñ5%	Murata	
CG0120	C312	SMD capasitor NPO	12pF ñ5%	Murata	
CG0180	C314	SMD capasitor NPO	18pF ñ5%	Murata	
CG0101	C320	SMD capasitor X7R	100pF ñ5%	Murata	
CF0223	C321	SMD capasitor	22 nF 10% 50 V X7R	Philips	
CG0109	C322	SMD capasitor NPO	1.0pF ñ0,25pF	Murata	
CG0479	C323	SMD capasitor NPO	4.7pF ñ0,25pF	Murata	

CODE	PART	DESCRIPT.	VALUE	MANUF.	TYPE
CG0101	C326	SMD capasitor X7R	100pF ñ5%	Murata	
CG0101	C328	SMD capasitor X7R	100pF ñ5%	Murata	
CU3106	C329	SMD tantal	10uF / 6V +20%	AVX	TAJA106M006R
CC0223	C341	SMD capasitor	22 nF 10% 50 V X7R	Philips	
CU0334	C342	SMD tantalium capasitor	0.33uF/20V/20%	AVX/KYO-CER	TAJR334M020R
CC0103	C343	SMD capasitor	10 nF 10% 50V X7R	Philips	
CC0223	C344	SMD capasitor	22 nF 10% 50 V X7R	Philips	
CH0105	C350	SMD capasitor	1uF/-20/+80%/16V	TaiyoYuden	EMK212 F105Z00T
CF0223	C351	SMD capasitor	22 nF 10% 50 V X7R	Philips	
CU2105	C360	SMD tantal	1uF/10V	AVX	TAJR105M010R
CG0103	C361	SMD capasitor X7R	10nF ñ10%	Murata	
CG0330	C362	SMD capasitor NPO	33pF ñ5%	Murata	
CF0103	C365	SMD capasitor	10 nF 10% 50 V X7R	Philips	
CG0101	C367	SMD capasitor X7R	100pF ñ5%	Murata	
CU0105	C380	SMD tantal	1uF/16V 20% 3.2x1.6mm	Matsushita	ECST1CY 105R
CC0104	C381	SMD capasitor	100 nF 10% 50V X7R	Philips	
CU3106	C382	SMD tantal	10uF / 6V +20%	AVX	TAJA106M006R
CG0102	C383	SMD capasitor X7R	1nF ñ10%	Murata	
CU2105	C384	SMD tantal	1uF/10V	AVX	TAJR105M010R
CG0101	C401	SMD capasitor X7R	100pF ñ5%	Murata	
CG0101	C402	SMD capasitor X7R	100pF ñ5%	Murata	
CG0220	C403	SMD capasitor NPO	22pF ñ5%	Murata	
CG0189	C404	SMD capasitor NPO	1.8pF ñ0,25pF	Murata	
CG0479	C410	SMD capasitor NPO	4.7pF ñ0,25pF	Murata	
CG0150	C411	SMD capasitor NPO	15pF ñ5%	Murata	
CG0120	C412	SMD capasitor NPO	12pF ñ5%	Murata	
CG0390	C414	SMD capasitor NPO	39pF ñ5%	Murata	
CG0101	C420	SMD capasitor X7R	100pF ñ5%	Murata	
CF0223	C421	SMD capasitor	22 nF 10% 50 V X7R	Philips	
CG0109	C422	SMD capasitor NPO	1.0pF ñ0,25pF	Murata	
CG0390	C423	SMD capasitor NPO	39pF ñ5%	Murata	
CG0101	C426	SMD capasitor X7R	100pF ñ5%	Murata	
CG0101	C428	SMD capasitor X7R	100pF ñ5%	Murata	
CU3106	C429	SMD tantal	10uF / 6V +20%	AVX	TAJA106M006R
CG0101	C430	SMD capasitor X7R	100pF ñ5%	Murata	
CG0101	C432	SMD capasitor X7R	100pF ñ5%	Murata	
CG0109	C433	SMD capasitor NPO	1.0pF ñ0,25pF	Murata	
CG0569	C434	SMD capasitor NPO	5.6pF ñ0,25pF	Murata	
CG0101	C435	SMD capasitor X7R	100pF ñ5%	Murata	
CC0473	C441	SMD capasitor	47 nF 10% 50 V X7R	Philips	
CU2105	C442	SMD tantal	1uF/10V	AVX	TAJR105M010R
CC0103	C443	SMD capasitor	10 nF 10% 50V X7R	Philips	
CC0223	C444	SMD capasitor	22 nF 10% 50 V X7R	Philips	
CH0105	C450	SMD capasitor	1uF/-20/+80%/16V	TaiyoYuden	EMK212 F105Z00T
CF0223	C451	SMD capasitor	22 nF 10% 50 V X7R	Philips	
CU0334	C461	SMD tantalium capasitor	0.33uF/20V/20%	AVX/KYO-CER	TAJR334M020R
CU0334	C462	SMD tantalium capasitor	0.33uF/20V/20%	AVX/KYO-CER	TAJR334M020R
CC0104	C481	SMD capasitor	100 nF 10% 50V X7R	Philips	
CU3106	C482	SMD tantal	10uF / 6V +20%	AVX	TAJA106M006R
CG0102	C483	SMD capasitor X7R	1nF ñ10%	Murata	
CU0224	C484	SMD tanlat	0.22uF/20V/10%	AVX/KYO-CER	TAJR224K020R
CC0104	C601	SMD capasitor	100 nF 10% 50V X7R	Philips	
CU1105	C602	SMD tantal	1uF/16V	AVX	TAJR105M016R
CG0102	C603	SMD capasitor X7R	1nF ñ10%	Murata	
CG0103	C604	SMD capasitor X7R	10nF ñ10%	Murata	
CU3106	C605	SMD tantal	10uF / 6V +20%	AVX	TAJA106M006R

CODE	PART	DESCRIPT.	VALUE	MANUF.	TYPE
CG0390	C606	SMD capasitor NPO	39pF \bar{n} 5%	Murata	
CU2105	C608	SMD tantal	1uF/10V	AVX	TAJR105M010R
CG0103	C609	SMD capasitor X7R	10nF \bar{n} 10%	Murata	
CG0101	C610	SMD capasitor X7R	100pF \bar{n} 5%	Murata	
CG0101	C611	SMD capasitor X7R	100pF \bar{n} 5%	Murata	
CG0569	C612	SMD capasitor NPO	5.6pF \bar{n} 0,25pF	Murata	
CG0221	C613	SMD capasitor X7R	220pF \bar{n} 10%	Murata	
CG0103	C614	SMD capasitor X7R	10nF \bar{n} 10%	Murata	
CU2105	C615	SMD tantal	1uF/10V	AVX	TAJR105M010R
CG0103	C616	SMD capasitor X7R	10nF \bar{n} 10%	Murata	
CU2105	C617	SMD tantal	1uF/10V	AVX	TAJR105M010R
CU0225	C618	SMD tantal	2.2uF/16V 20% 4.7x2.6mm	Matsushita	ECST1CB 225R
CG0102	C619	SMD capasitor X7R	1nF \bar{n} 10%	Murata	
CG0222	C620	SMD capasitor X7R	2.2nF \bar{n} 10%	Murata	
CG0332	C621	SMD capasitor X7R	3.3nF \bar{n} 10%	Murata	
CU2105	C622	SMD tantal	1uF/10V	AVX	TAJR105M010R
CG0102	C623	SMD capasitor X7R	1nF \bar{n} 10%	Murata	
CU0225	C624	SMD tantal	2.2uF/16V 20% 4.7x2.6mm	Matsushita	ECST1CB 225R
CQ0330	C625	SMD MQ capasitor	33pF 25V 1%	AVX	06033K330FAWTR
CG0101	C626	SMD capasitor X7R	100pF \bar{n} 5%	Murata	
CG0101	C627	SMD capasitor X7R	100pF \bar{n} 5%	Murata	
CG0101	C628	SMD capasitor X7R	100pF \bar{n} 5%	Murata	
CG0101	C629	SMD capasitor X7R	100pF \bar{n} 5%	Murata	
CG0103	C630	SMD capasitor X7R	10nF \bar{n} 10%	Murata	
CG0102	C631	SMD capasitor X7R	1nF \bar{n} 10%	Murata	
CG0102	C632	SMD capasitor X7R	1nF \bar{n} 10%	Murata	
CG0102	C633	SMD capasitor X7R	1nF \bar{n} 10%	Murata	
CG0102	C634	SMD capasitor X7R	1nF \bar{n} 10%	Murata	
CG0103	C635	SMD capasitor X7R	10nF \bar{n} 10%	Murata	
CG0221	C636	SMD capasitor X7R	220pF \bar{n} 10%	Murata	
CG0102	C638	SMD capasitor X7R	1nF \bar{n} 10%	Murata	
CG0102	C639	SMD capasitor X7R	1nF \bar{n} 10%	Murata	
CG0102	C640	SMD capasitor X7R	1nF \bar{n} 10%	Murata	
CG0221	C641	SMD capasitor X7R	220pF \bar{n} 10%	Murata	
CG0221	C642	SMD capasitor X7R	220pF \bar{n} 10%	Murata	
CG0221	C643	SMD capasitor X7R	220pF \bar{n} 10%	Murata	
CG0103	C644	SMD capasitor X7R	10nF \bar{n} 10%	Murata	
CG0220	C645	SMD capasitor NPO	22pF \bar{n} 5%	Murata	
CG0103	C646	SMD capasitor X7R	10nF \bar{n} 10%	Murata	
DC0229	D301	SMD silicon tuning diode	1V/19pF...4V/11pF	Toshiba	1SV229
DC0229	D401	SMD silicon tuning diode	1V/19pF...4V/11pF	Toshiba	1SV229
DZ3399	D600	SMD zener	3V9 5% 500mW	Temic	BZM55C3V9 TR3
DY0062	D610	SMD shcottky diode	40V 20mA	Siemens	BAT 62
DY0384	D630	SMD shottky barrier diod	15V/200mA/VF=0.35V	Toshiba	1SS384-TE85L
IV6070	I201	FM IF-system		Philips	SA607DK
IS2335	I300	Dual freg.synthesizer	PLL+prescaler 1.2GHz	NationalSe	LMX23352TMX
IR1238	I380	Regulator	3.8V/240mA +-2,4%	Toko	TK11238AM
IR1238	I480	Regulator	3.8V/240mA +-2,4%	Toko	TK11238AM
IW2792	I600	RF-power amplifier	450MHz-485MHz	Iwatsu	HAB279B
IR1238	I601	Regulator	3.8V/240mA +-2,4%	Toko	TK11238AM
IA7550	I610	Single op.amp.		Toshiba	TA 75S01F-TE85L
IC7S00	I620	2-input NAND	SOT-23-5	NationalSe	NC7S00M5X
LC3392	L101	SMD inductor	3n9 +-2%	Panasonic	ELJRE3N9ZF2
LC3123	L102	SMD inductor	12n +-2%	Panasonic	ELJRE12NGF2
LC3334	L103	SMD inductor	330nH +-10%	TDK	MLF1608DR33K
LC3334	L104	SMD inductor	330nH +-10%	TDK	MLF1608DR33K
LC3223	L105	SMD inductor	22n +-2%	Panasonic	ELJRE22NGF2
LC3472	L106	SMD inductor	4n7 +-2%	Panasonic	ELJRE4N7ZF2
LC3273	L107	SMD inductor	27nH +-2%	Panasonic	ELJRE27NGF2
LC3334	L201	SMD inductor	330nH +-10%	TDK	MLF1608DR33K

CODE	PART	DESCRIPT.	VALUE	MANUF.	TYPE
LC3104	L202	SMD inductor	100nH+-10% magnet.shielded	TDK	MLF1608DR10KT
LI0450	L203	SMD Quad. coil	450kHz	Sagami	950997404
LC3224	L204	SMD inductor	220nH+-10% magnet.shielded	TDK	MLF1608DR22KT
LC1224	L301	SMD inductor	220 nH/+ -10%	Coilcraft	0805CS-221XKBC
LC1224	L401	SMD inductor	220 nH/+ -10%	Coilcraft	0805CS-221XKBC
LC3183	L430	SMD inductor	18n +-2%	Panasonic	ELJRE18NGF2
LC4106	L600	SMD inductor	10uH +-10%	TDK	MLF3216E100KT
QF0284	Q101	SMD GaAs dual N-channel		Toshiba	3SK284
QF0284	Q102	SMD GaAs dual N-channel		Toshiba	3SK284
QA4867	Q201	SMD RF-transistor	NPN G=13dB NF=1.2dB/1GHz	Sanyo	2SC4867-4
QA4867	Q310	SMD RF-transistor	NPN G=13dB NF=1.2dB/1GHz	Sanyo	2SC4867-4
QA4867	Q320	SMD RF-transistor	NPN G=13dB NF=1.2dB/1GHz	Sanyo	2SC4867-4
QS1847	Q360	piensignaali yleistransi	NPN 100mA/45V hfe=200...450	Philips	BC847BW
QA4867	Q410	SMD RF-transistor	NPN G=13dB NF=1.2dB/1GHz	Sanyo	2SC4867-4
QA4867	Q420	SMD RF-transistor	NPN G=13dB NF=1.2dB/1GHz	Sanyo	2SC4867-4
QA4867	Q430	SMD RF-transistor	NPN G=13dB NF=1.2dB/1GHz	Sanyo	2SC4867-4
QA4867	Q600	SMD RF-transistor	NPN G=13dB NF=1.2dB/1GHz	Sanyo	2SC4867-4
QA4867	Q605	SMD RF-transistor	NPN G=13dB NF=1.2dB/1GHz	Sanyo	2SC4867-4
QS1847	Q610	piensignaali yleistransi	NPN 100mA/45V hfe=200...450	Philips	BC847BW
QS0031	Q620	SMD transistor	PNP 1A/25V	Sanyo	2SB1119S-TD
QS1847	Q630	piensignaali yleistransi	NPN 100mA/45V hfe=200...450	Philips	BC847BW
QF7002	Q640	SMD n-channel FET	60V 0.115A Rds7.5	Siliconix	2N7002-T1
QAA193	Q650	SMD RF-transistor	6GHz/300mW F=1.9dB	Philips	BFR93AW
QF9430	Q660	SMD p-channel MOSFET	20V/4,8A/Rds=0.06	Siliconix	Si9430DY
RG0103	R100	SMD resistor	10k 5% 0.063W	Kamaya	RMC1/16S
RG0102	R101	SMD resistor	1k0 5% 0.063W	Kamaya	RMC1/16S
RG0102	R102	SMD resistor	1k0 5% 0.063W	Kamaya	RMC1/16S
RG0100	R103	SMD resistor	10 R 5% 0.063W	Kamaya	RMC1/16S
RG0101	R104	SMD resistor	100R 5% 0.063W	Kamaya	RMC1/16S
RG0102	R105	SMD resistor	1k0 5% 0.063W	Kamaya	RMC1/16S
RG0471	R106	SMD resistor	470R 5% 0.063W	Kamaya	RMC1/16S
RG0472	R107	SMD resistor	4k7 5% 0.063W	Kamaya	RMC1/16S
RG0220	R108	SMD resistor	22R 5% 0.063W	Kamaya	RMC1/16S
RG0100	R110	SMD resistor	10 R 5% 0.063W	Kamaya	RMC1/16S
RG0180	R112	SMD resistor	18R 5% 0.063W	Kamaya	RMC1/16S
RG0271	R114	SMD resistor	270R 5% 0.063W	Kamaya	RMC1/16S
RG0271	R115	SMD resistor	270R 5% 0.063W	Kamaya	RMC1/16S
RG0100	R116	SMD resistor	10 R 5% 0.063W	Kamaya	RMC1/16S
RG0472	R201	SMD resistor	4k7 5% 0.063W	Kamaya	RMC1/16S
RG0102	R202	SMD resistor	1k0 5% 0.063W	Kamaya	RMC1/16S
RG0222	R203	SMD resistor	2k2 5% 0.063W	Kamaya	RMC1/16S
RG0332	R204	SMD resistor	3k3 5% 0.063W	Kamaya	RMC1/16S
RG0273	R205	SMD resistor	27k 5% 0.063W	Kamaya	RMC1/16S
RG0100	R206	SMD resistor	10 R 5% 0.063W	Kamaya	RMC1/16S
RG0472	R207	SMD resistor	4k7 5% 0.063W	Kamaya	RMC1/16S
RG0220	R208	SMD resistor	22R 5% 0.063W	Kamaya	RMC1/16S
RG0473	R209	SMD resistor	47k 5% 0.063W	Kamaya	RMC1/16S
RG0393	R210	SMD resistor	39k 5% 0.063W	Kamaya	RMC1/16S
RG0683	R211	SMD resistor	68k 5% 0.063W	Kamaya	RMC1/16S
RTN157	R212	(RNT157)NTC resistor	22k 5% B=3750	Ohizumi	157-223-65001
RG0682	R213	SMD resistor	6k8 5% 0.063W	Kamaya	RMC1/16S
RG0102	R214	SMD resistor	1k0 5% 0.063W	Kamaya	RMC1/16S
RG0683	R215	SMD resistor	68k 5% 0.063W	Kamaya	RMC1/16S
RG0473	R216	SMD resistor	47k 5% 0.063W	Kamaya	RMC1/16S
RG0272	R220	SMD resistor	2k7 5% 0.063W	Kamaya	RMC1/16S
RG0822	R310	SMD resistor	8k2 5% 0.063W	Kamaya	RMC1/16S
RG0222	R311	SMD resistor	2k2 5% 0.063W	Kamaya	RMC1/16S
RG0101	R312	SMD resistor	100R 5% 0.063W	Kamaya	RMC1/16S
RG0220	R320	SMD resistor	22R 5% 0.063W	Kamaya	RMC1/16S
RG0472	R321	SMD resistor	4k7 5% 0.063W	Kamaya	RMC1/16S

CODE	PART	DESCRIPT.	VALUE	MANUF.	TYPE
RG0152	R322	SMD resistor	1k5 5% 0.063W	Kamaya	RMC1/16S
RG0151	R325	SMD resistor	150R 5% 0.063W	Kamaya	RMC1/16S
RG0151	R326	SMD resistor	150R 5% 0.063W	Kamaya	RMC1/16S
RG0150	R329	SMD resistor	15R 5% 0.063W	Kamaya	RMC1/16S
RG0272	R340	SMD resistor	2k7 5% 0.063W	Kamaya	RMC1/16S
RG0152	R341	SMD resistor	1k5 5% 0.063W	Kamaya	RMC1/16S
RG0152	R342	SMD resistor	1k5 5% 0.063W	Kamaya	RMC1/16S
RG0100	R343	SMD resistor	10 R 5% 0.063W	Kamaya	RMC1/16S
RG0470	R350	SMD resistor	47R 5% 0.063W	Kamaya	RMC1/16S
RG0470	R351	SMD resistor	47R 5% 0.063W	Kamaya	RMC1/16S
RG0150	R360	SMD resistor	15R 5% 0.063W	Kamaya	RMC1/16S
RG0103	R361	SMD resistor	10k 5% 0.063W	Kamaya	RMC1/16S
RG0473	R363	SMD resistor	47k 5% 0.063W	Kamaya	RMC1/16S
RG0104	R364	SMD resistor	100k 5% 0.063W	Kamaya	RMC1/16S
RG0103	R365	SMD resistor	10k 5% 0.063W	Kamaya	RMC1/16S
RG0473	R383	SMD resistor	47k 5% 0.063W	Kamaya	RMC1/16S
RG0472	R390	SMD resistor	4k7 5% 0.063W	Kamaya	RMC1/16S
RG0472	R391	SMD resistor	4k7 5% 0.063W	Kamaya	RMC1/16S
RG0472	R392	SMD resistor	4k7 5% 0.063W	Kamaya	RMC1/16S
RG0822	R410	SMD resistor	8k2 5% 0.063W	Kamaya	RMC1/16S
RG0222	R411	SMD resistor	2k2 5% 0.063W	Kamaya	RMC1/16S
RG0151	R412	SMD resistor	150R 5% 0.063W	Kamaya	RMC1/16S
RG0220	R420	SMD resistor	22R 5% 0.063W	Kamaya	RMC1/16S
RG0472	R421	SMD resistor	4k7 5% 0.063W	Kamaya	RMC1/16S
RG0152	R422	SMD resistor	1k5 5% 0.063W	Kamaya	RMC1/16S
RG0101	R425	SMD resistor	100R 5% 0.063W	Kamaya	RMC1/16S
RG0101	R426	SMD resistor	100R 5% 0.063W	Kamaya	RMC1/16S
RG0150	R429	SMD resistor	15R 5% 0.063W	Kamaya	RMC1/16S
RG0220	R430	SMD resistor	22R 5% 0.063W	Kamaya	RMC1/16S
RG0152	R431	SMD resistor	1k5 5% 0.063W	Kamaya	RMC1/16S
RG0150	R432	SMD resistor	15R 5% 0.063W	Kamaya	RMC1/16S
RG0221	R433	SMD resistor	220R 5% 0.063W	Kamaya	RMC1/16S
RG0472	R435	SMD resistor	4k7 5% 0.063W	Kamaya	RMC1/16S
RG0152	R440	SMD resistor	1k5 5% 0.063W	Kamaya	RMC1/16S
RG0472	R441	SMD resistor	4k7 5% 0.063W	Kamaya	RMC1/16S
RG0472	R442	SMD resistor	4k7 5% 0.063W	Kamaya	RMC1/16S
RG0100	R443	SMD resistor	10 R 5% 0.063W	Kamaya	RMC1/16S
RG0470	R450	SMD resistor	47R 5% 0.063W	Kamaya	RMC1/16S
RG0470	R451	SMD resistor	47R 5% 0.063W	Kamaya	RMC1/16S
RG0151	R460	SMD resistor	150R 5% 0.063W	Kamaya	RMC1/16S
RG0823	R461	SMD resistor	82k 5% 0.063W	Kamaya	RMC1/16S
RG0183	R463	SMD resistor	18k 5% 0.063W	Kamaya	RMC1/16S
RG0103	R464	SMD resistor	10k 5% 0.063W	Kamaya	RMC1/16S
RG0472	R465	SMD resistor	4k7 5% 0.063W	Kamaya	RMC1/16S
RG0473	R483	SMD resistor	47k 5% 0.063W	Kamaya	RMC1/16S
RG0103	R601	SMD resistor	10k 5% 0.063W	Kamaya	RMC1/16S
RG0224	R602	SMD resistor	220k 5% 0.063W	Kamaya	RMC1/16S
RG0473	R603	SMD resistor	47k 5% 0.063W	Kamaya	RMC1/16S
RG0101	R604	SMD resistor	100R 5% 0.063W	Kamaya	RMC1/16S
RG0821	R605	SMD resistor	820R 5% 0.063W	Kamaya	RMC1/16S
RG0272	R606	SMD resistor	2k7 5% 0.063W	Kamaya	RMC1/16S
RG0391	R607	SMD resistor	390R 5% 0.063W	Kamaya	RMC1/16S
RG0100	R608	SMD resistor	10 R 5% 0.063W	Kamaya	RMC1/16S
RG0391	R609	SMD resistor	390R 5% 0.063W	Kamaya	RMC1/16S
RG0224	R610	SMD resistor	220k 5% 0.063W	Kamaya	RMC1/16S
RG0102	R611	SMD resistor	1k0 5% 0.063W	Kamaya	RMC1/16S
RG0102	R612	SMD resistor	1k0 5% 0.063W	Kamaya	RMC1/16S
RG0271	R613	SMD resistor	270R 5% 0.063W	Kamaya	RMC1/16S
RG0103	R615	SMD resistor	10k 5% 0.063W	Kamaya	RMC1/16S
RG0184	R616	SMD resistor	180k 5% 0.063W	Kamaya	RMC1/16S

CODE	PART	DESCRIPT.	VALUE	MANUF.	TYPE
RG0104	R617	SMD resistor	100k 5% 0.063W	Kamaya	RMC1/16S
RG0103	R618	SMD resistor	10k 5% 0.063W	Kamaya	RMC1/16S
RG0151	R619	SMD resistor	150R 5% 0.063W	Kamaya	RMC1/16S
RG0220	R620	SMD resistor	22R 5% 0.063W	Kamaya	RMC1/16S
RG0224	R621	SMD resistor	220k 5% 0.063W	Kamaya	RMC1/16S
RG0105	R622	SMD resistor	1M0 5% 0.063W	Kamaya	RMC1/16S
RG0101	R623	SMD resistor	100R 5% 0.063W	Kamaya	RMC1/16S
RG0220	R624	SMD resistor	22R 5% 0.063W	Kamaya	RMC1/16S
RG0220	R626	SMD resistor	22R 5% 0.063W	Kamaya	RMC1/16S
RG0220	R627	SMD resistor	22R 5% 0.063W	Kamaya	RMC1/16S
RG0102	R628	SMD resistor	1k0 5% 0.063W	Kamaya	RMC1/16S
RG0332	R629	SMD resistor	3k3 5% 0.063W	Kamaya	RMC1/16S
RG0102	R630	SMD resistor	1k0 5% 0.063W	Kamaya	RMC1/16S
RG0102	R631	SMD resistor	1k0 5% 0.063W	Kamaya	RMC1/16S
VM0019	V600	SMD B/B-connector 3mm	20 pin	Matsushita	AXN320038P
OD1920	X100	Duplexer Nordic	Rx 465MHz Tx 455MHz	Solitra	NBS46106
XM0006	X102	Dual balanced mixer	450 MHz	MiniCircui	RMS-1LL
XF7755	X103	Crystal filter	77,55MHz	Toyocom	TN4-6516
XC3450	X201	Ceramic IF-filter	450Khz	Murata	CFUCG450E
XC4450	X202	Ceramic IF-filter	450kHz	Murata	CFUCG450F
XR1650	X301	Ceramic coaxial resonato	650MHz 4x4x13mm Q>250	Siemens	B69614-G0655-B42
XO4128	X360	VCTCXO Nord.	12.85 MHz / 3V	TEW	TTC01V
XR1550	X401	Ceramic coaxial resonato	550MHz 4x4x14,5mm Q>250	Siemens	B69614-G0550-BA4
XI0005	X600	Directional coupler	NMT450	MKT Taisei	DCS3120-09
LF0062	X610	SMD EMI filter	10nF/2A	Panasonic	ELKE103FA
PY1900	YPCB2	PCB for OY1900			
MD1900	YST40	Tx-VCO cover	9,3x22,1mm	SMC Ltd.	972388
MD1901	YST40	Rx-VCO cover	9,3x20,1mm	SMC Ltd	972389
MD1902	YTX1	Tx-hybrid spiral sheet m	etal	SMC Ltd	972412
MD1902	YTX2	Tx-hybrid spiral sheet m	etal	SMC Ltd	972412

Last
update
11.10.99

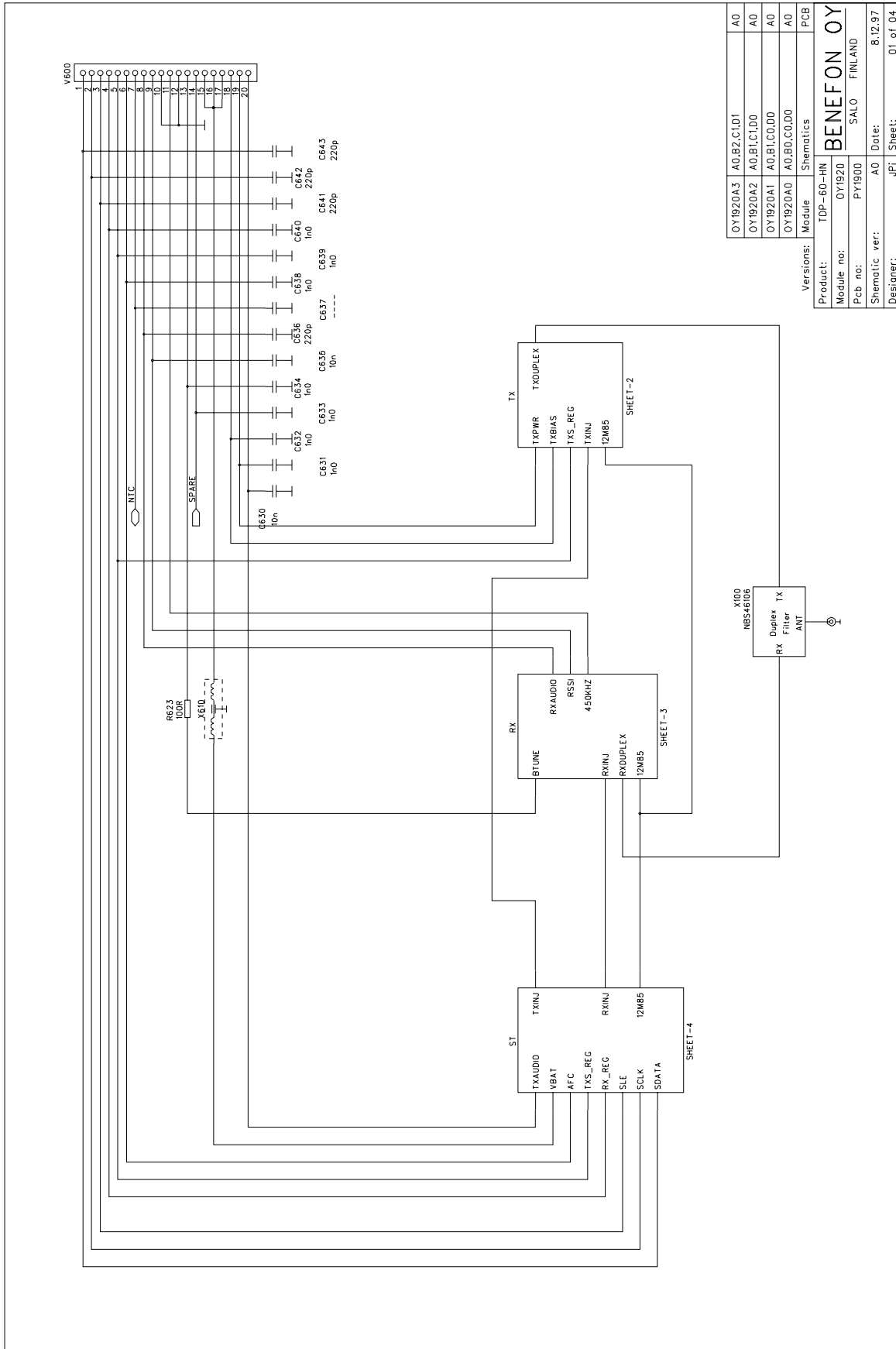

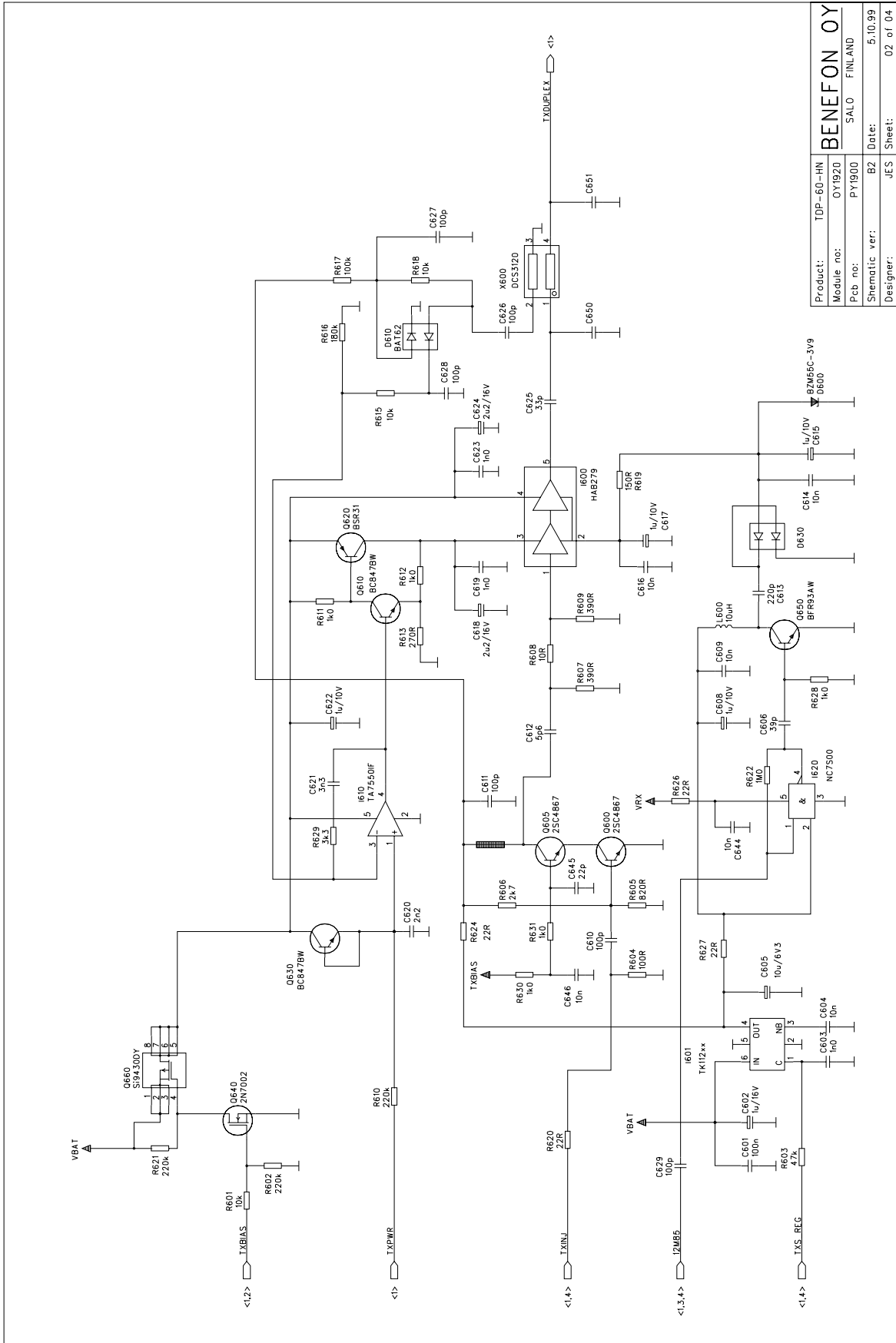

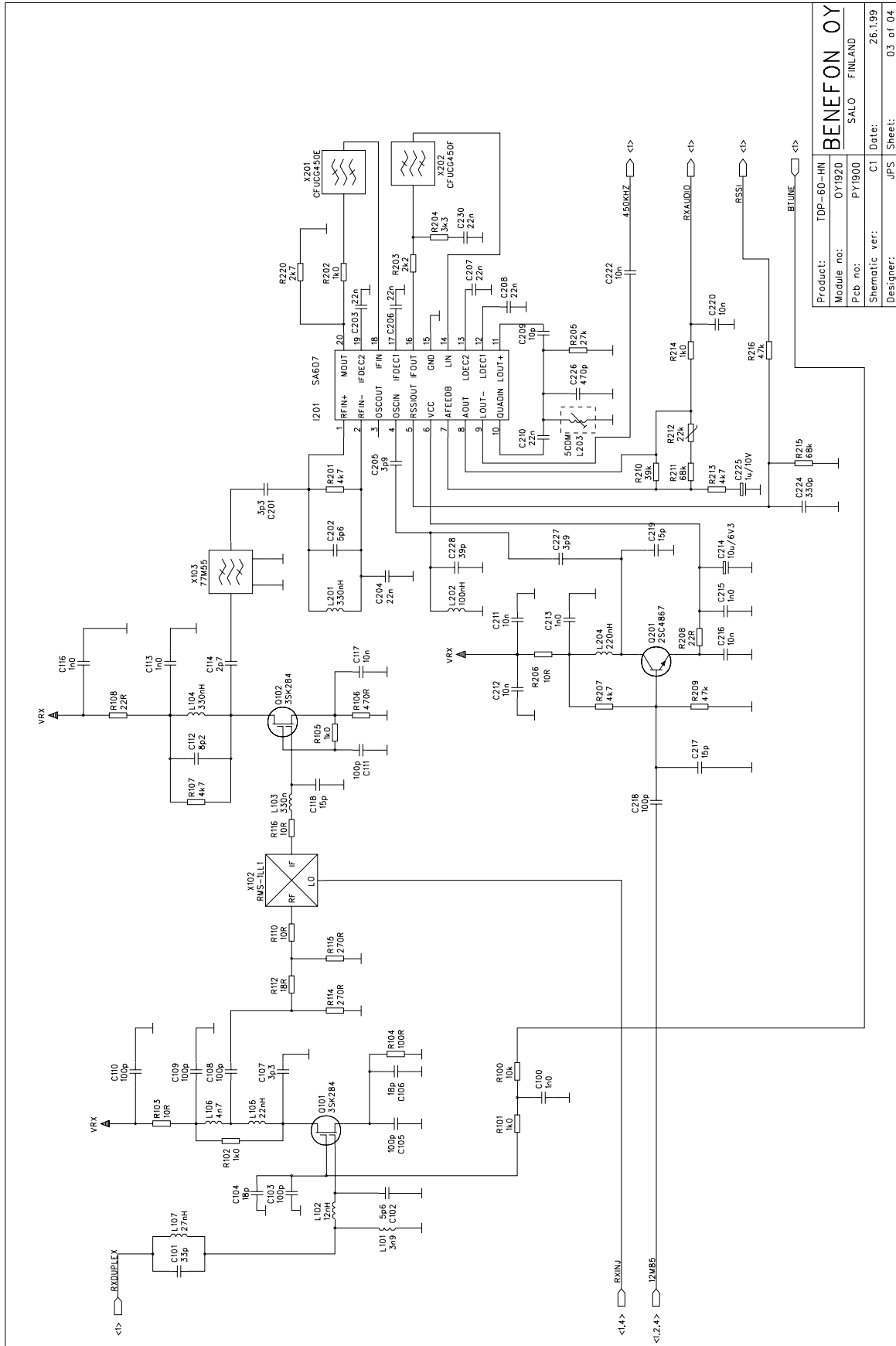

Product:	TDP-60-HN	BENEFON OY
Module no:	OY1920	
Pcb no:	PY1900	SALO FINLAND
Schematic ver:	C1	Date: 26.1.99
Designer:	JPS	Sheet: 03 of 04

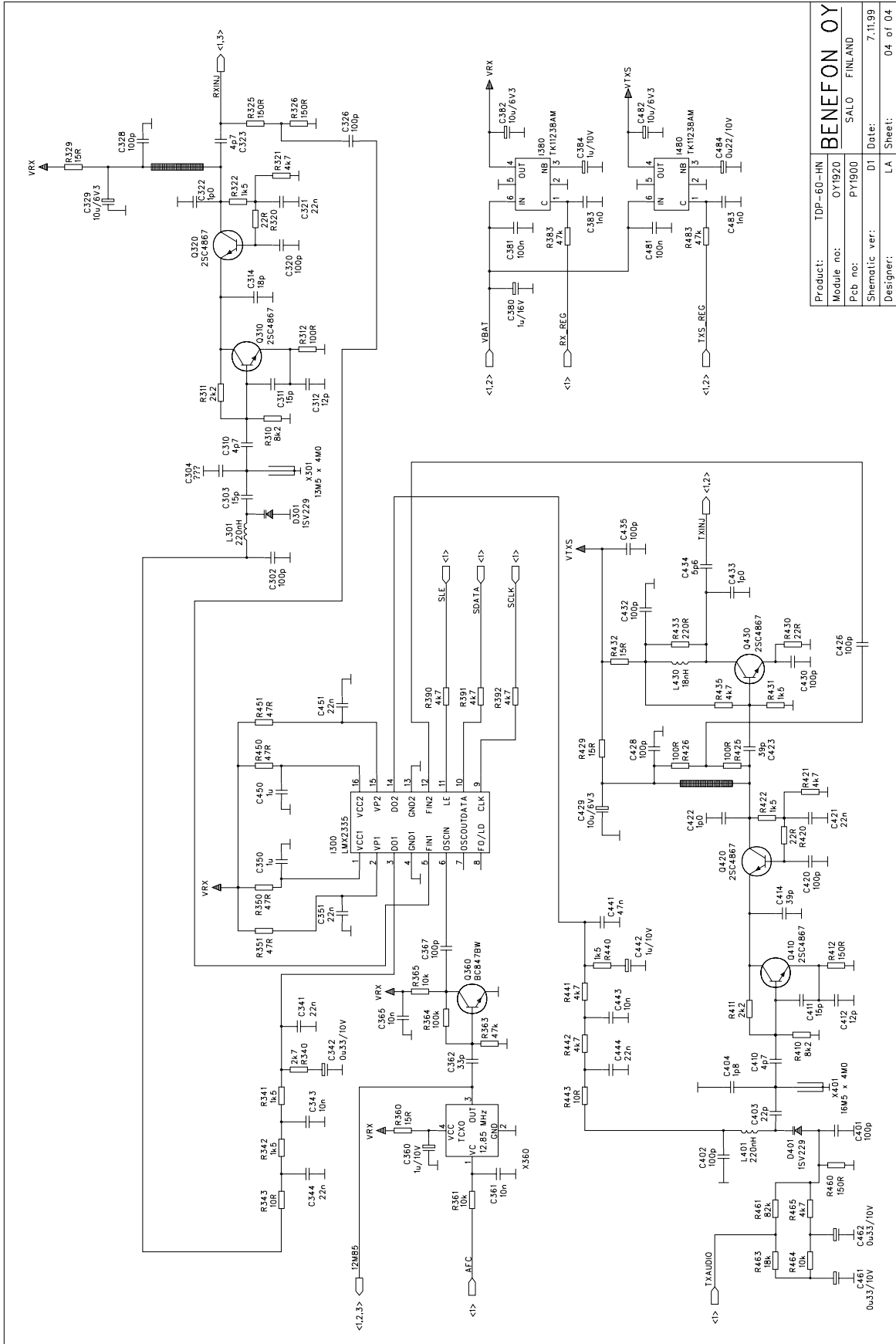

Product:	TDP-60-HN	BENEFON OY	
Module no:	OY1920	FINLAND	
Pcb no:	PY1900	SALO	
Schematic ver:	D1	Date:	7.11.99
Designer:	LA	Sheet:	04 of 04

6.0 CAR ASSEMBLY KIT

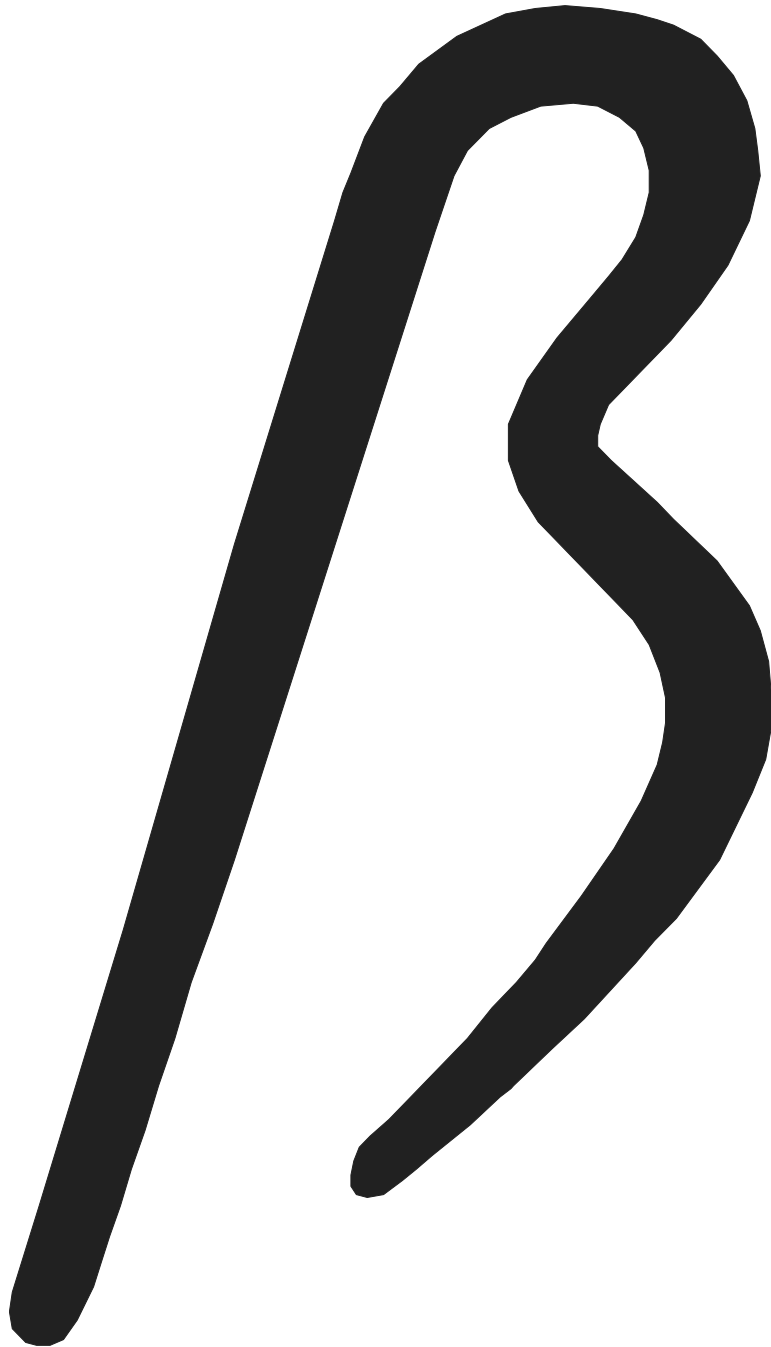

CAR ASSEMBLY KIT

6.1 CARBOX UDH-60

YO1951

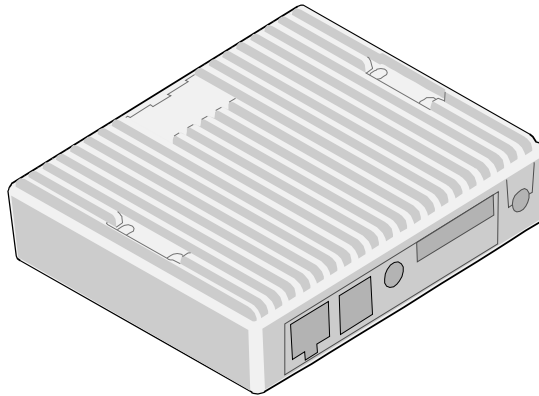

6.1.1 Including attached functions

- power supply filter
- voltage regulators
- processor controlled battery charger
- controls for external relays (AL, MUTE)
- handsfree amplifiers
- PC/AUX-connector
- handset connector
- integrated branching unit

6.1.2 Connector descriptions

6.1.2.1 EXTVB V100

1	MUTE	car radio mute	max. 500 mA
2	GND	speaker ground	
3	GND	ground	
4	AL	external alarm control	max 500 mA
5	HF_SPKR	HF-speaker	4 ohm 1.5 W
6	VBATT	operating voltage	10.8 - 18 V max 3A

6.1.2.2 HANDSET V102:

1	HS_ERP	Audio signal for earphone + HOOK-signal
2	EGND	
3	MGND	
4	HS_MIC	HS Microphone signal to carbox

6.1.2.3 EXTMIC V103

1	GND	ground
2	NC	not connected
3	HFMIC	HF Microphone signal to carbox
4	GND	ground
5	NC	not connected

6.1.2.4 PC/AUX V104

1	NC	not connected	
2	NC	not connected	
3	9V	PC	9V 500 mA
4	NC	not connected	
5	AUX_MIC	audio in	200 mV RMS
6	GND	ground	
7	GND	ground	
8	AUX_ERP	audio out	100 mV RMS
9	CADET	external target	+3.3 V
10	I2CINT	I ² C interrupt	
11	SCL	I ² C clock	
12	SDA	I ² C data	
13	TXD	RS 232	
14	RXD	RS 232	
15	EXTIO	extra-IO	
16	NC	not connected	

6.1.2.5 BOX V105

1	V_CHARGE	battery charging current	max. 1.1A / 8V
2	V_CHARGE	battery charging current	
3	V-BAT	battery voltage	
4	NC	not connected	
5	EXTMIC	external microphone signal	200 mV RMS
6	P_GND	ground	
7	GND	ground	
8	EXTERP	external ERP-signal	100 mV RMS
9	CADET	external target	+3.3 V
10	I2CINT	I ² C interrupt	
11	SCL	I ² C clock	
12	SDA	I ² C data	
13	TXD	RS 232	
14	RXD	RS 232	
15	EXTIO	extra-IO	
16	CHGCONT	charging control from the processor	

6.1.2.6 Operation

Operating voltage is fed to pin EXTVB/6. L100/C104 filters the power supply and D100 limits any voltage peaks. When the radio telephone is placed in its handset, a voltage is fed through the BOX/3 pin which triggers Q201 and Q200 open.

The regulator I200 feeds +9V to the audio stage and PC-connector pin 3 and I210 feeds +3.3 V to other functions. External relay drivers Q231 and Q241 are controlled by I²C I/O-expander I220.

The HF microphone gets its bias voltage through resistors R330 and R331. I330 serves as the microphone amplifier and as a low-pass filter with a border frequency of 3.3 kHz.

The analog switch I320 connects the HF microphone or HS microphone signal to the EXTMIC-line.

The analog switch I322, controlled by AUX_MODE selects either microphone (HS or HF) or external signal source AUX_MIC to be connected to EXTMIC signal pin.

The analog switch I430 connects audio signal to handset earphone or HF-speaker.

The analog switch I431 connects audio signal to connector PC/AUX/8 or to HS erp / HF spkr.

When audio power amplifiers I410 and I460 are not in use, they are in mute-mode.

6.1.3 Parts list OW1951

OW1951

CODE	PART	DESCRIPT.	VALUE	MANUF.	TYPE
CD0101	C100	SMD capasitor	100 pF 5% 50 V NP0	Philips	
CD0222	C101	SMD capasitor	2.2 nF 5% 50 V NP0	Philips	
CD0223	C102	SMD capasitor	22 nF 10% 50 V X7R	Philips	
CD0223	C103	SMD capasitor	22 nF 10% 50 V X7R	Philips	
CE0109	C104	Al-elko	1000uF/40V 12.5x30mm	Philips	2222 021 17102
CD0222	C105	SMD capasitor	2.2 nF 5% 50 V NP0	Philips	
CD0222	C106	SMD capasitor	2.2 nF 5% 50 V NP0	Philips	
CD0102	C110	SMD capasitor	1 nF 5 % NP0	Philips	
CD0102	C111	SMD capasitor	1 nF 5 % NP0	Philips	
CD0471	C112	SMD capasitor	470 pF 5% 50 V NP0	Philips	
CD0101	C120	SMD capasitor	100 pF 5% 50 V NP0	Philips	
CD0101	C121	SMD capasitor	100 pF 5% 50 V NP0	Philips	
CD0101	C122	SMD capasitor	100 pF 5% 50 V NP0	Philips	
CD0101	C123	SMD capasitor	100 pF 5% 50 V NP0	Philips	
CD0101	C124	SMD capasitor	100 pF 5% 50 V NP0	Philips	
CD0101	C125	SMD capasitor	100 pF 5% 50 V NP0	Philips	
CD0101	C130	SMD capasitor	100 pF 5% 50 V NP0	Philips	
CD0101	C131	SMD capasitor	100 pF 5% 50 V NP0	Philips	
CD0101	C132	SMD capasitor	100 pF 5% 50 V NP0	Philips	
CD0101	C133	SMD capasitor	100 pF 5% 50 V NP0	Philips	
CD0101	C134	SMD capasitor	100 pF 5% 50 V NP0	Philips	
CD0101	C135	SMD capasitor	100 pF 5% 50 V NP0	Philips	
CD0101	C136	SMD capasitor	100 pF 5% 50 V NP0	Philips	
CD0101	C137	SMD capasitor	100 pF 5% 50 V NP0	Philips	
CD0101	C138	SMD capasitor	100 pF 5% 50 V NP0	Philips	
CD0101	C139	SMD capasitor	100 pF 5% 50 V NP0	Philips	
CD0101	C140	SMD capasitor	100 pF 5% 50 V NP0	Philips	
CD0101	C141	SMD capasitor	100 pF 5% 50 V NP0	Philips	
CD0223	C200	SMD capasitor	22 nF 10% 50 V X7R	Philips	
CD0223	C201	SMD capasitor	22 nF 10% 50 V X7R	Philips	
CU1106	C202	SMD tantal	10uF/16V	AVX	TAJB106M016R
CD0104	C203	SMD capasitor	100 nF 10% 50 V X7R	Philips	
CD0104	C204	SMD capasitor	100 nF 10% 50 V X7R	Philips	
CD0223	C205	SMD capasitor	22 nF 10% 50 V X7R	Philips	
CD0123	C206	SMD capasitor	12nF 10% 50V X7R	Philips	
CD0473	C207	SMD capasitor	47 nF 10% 50 V X7R	Philips	
CD0473	C208	SMD capasitor	47 nF 10% 50 V X7R	Philips	
CD0223	C210	SMD capasitor	22 nF 10% 50 V X7R	Philips	
CU1106	C211	SMD tantal	10uF/16V	AVX	TAJB106M016R
CD0103	C212	SMD capasitor	10 nF 10% 50 V X7R	Philips	
CU1106	C213	SMD tantal	10uF/16V	AVX	TAJB106M016R
CD0223	C220	SMD capasitor	22 nF 10% 50 V X7R	Philips	
CD0222	C230	SMD capasitor	2.2 nF 5% 50 V NP0	Philips	
CD0222	C240	SMD capasitor	2.2 nF 5% 50 V NP0	Philips	
CU0105	C300	SMD tantal	1uF/16V 20% 3.2x1.6mm	Matsushita	ECST1CY 105R
CD0223	C301	SMD capasitor	22 nF 10% 50 V X7R	Philips	
CD0222	C302	SMD capasitor	2.2 nF 5% 50 V NP0	Philips	
CD0223	C303	SMD capasitor	22 nF 10% 50 V X7R	Philips	
CD0680	C304	SMD capasitor	68 pF 5% 50 V NP0	Philips	
CD0471	C305	SMD capasitor	470 pF 5% 50 V NP0	Philips	
CD0270	C306	SMD capasitor	27pF 5% 50V NPO	Philips	
CD0270	C307	SMD capasitor	27pF 5% 50V NPO	Philips	
CD0101	C320	SMD capasitor	100 pF 5% 50 V NP0	Philips	
CD0223	C321	SMD capasitor	22 nF 10% 50 V X7R	Philips	
CH0105	C322	SMD capasitor	1uF/-20/+80%/16V	TaiyoYuden	EMK212 F105Z00T

CODE	PART	DESCRIPT.	VALUE	MANUF.	TYPE
CD0471	C323	SMD capasitor	470 pF 5% 50 V NPO	Philips	
CD0270	C324	SMD capasitor	27pF 5% 50V NPO	Philips	
CD0270	C325	SMD capasitor	27pF 5% 50V NPO	Philips	
CD0270	C326	SMD capasitor	27pF 5% 50V NPO	Philips	
CD0270	C327	SMD capasitor	27pF 5% 50V NPO	Philips	
CD0270	C328	SMD capasitor	27pF 5% 50V NPO	Philips	
CU0105	C330	SMD tantal	1uF/16V 20% 3.2x1.6mm	Matsushita	ECST1CY 105R
CD0104	C331	SMD capasitor	100 nF 10% 50 V X7R	Philips	
CD0222	C332	SMD capasitor	2.2 nF 5% 50 V NPO	Philips	
CD0680	C333	SMD capasitor	68 pF 5% 50 V NPO	Philips	
CD0223	C334	SMD capasitor	22 nF 10% 50 V X7R	Philips	
CD0221	C335	SMD capasitor	220 pF 5% 50 V NPO	Philips	
CD0270	C336	SMD capasitor	27pF 5% 50V NPO	Philips	
CD0270	C337	SMD capasitor	27pF 5% 50V NPO	Philips	
CU0105	C340	SMD tantal	1uF/16V 20% 3.2x1.6mm	Matsushita	ECST1CY 105R
CD0223	C401	SMD capasitor	22 nF 10% 50 V X7R	Philips	
CD0471	C402	SMD capasitor	470 pF 5% 50 V NPO	Philips	
CD0221	C405	SMD capasitor	220 pF 5% 50 V NPO	Philips	
CU0226	C411	SMD tantal	22uF/16V 10% 7.3x4.3mm	Kyocera	TAJD226K016R
CU0226	C413	SMD tantal	22uF/16V 10% 7.3x4.3mm	Kyocera	TAJD226K016R
CD0104	C414	SMD capasitor	100 nF 10% 50 V X7R	Philips	
CE0476	C415	Al elko	47 uF/25 V 7x7mm	Philips	2222 097 56479
CD0104	C416	SMD capasitor	100 nF 10% 50 V X7R	Philips	
CU1106	C417	SMD tantal	10uF/16V	AVX	TAJB106M016R
CU0225	C418	SMD tantal	2.2uF/16V 20% 4.7x2.6mm	Matsushita	ECST1CB 225R
CH0105	C419	SMD capasitor	1uF/-20/+80%/16V	TaiyoYuden	EMK212 F105Z00T
CH0105	C420	SMD capasitor	1uF/-20/+80%/16V	TaiyoYuden	EMK212 F105Z00T
CH0105	C421	SMD capasitor	1uF/-20/+80%/16V	TaiyoYuden	EMK212 F105Z00T
CD0221	C422	SMD capasitor	220 pF 5% 50 V NPO	Philips	
CD0103	C423	SMD capasitor	10 nF 10% 50 V X7R	Philips	
CD0222	C424	SMD capasitor	2.2 nF 5% 50 V NPO	Philips	
CH0105	C430	SMD capasitor	1uF/-20/+80%/16V	TaiyoYuden	EMK212 F105Z00T
CH0105	C431	SMD capasitor	1uF/-20/+80%/16V	TaiyoYuden	EMK212 F105Z00T
CD0270	C432	SMD capasitor	27pF 5% 50V NPO	Philips	
CD0270	C433	SMD capasitor	27pF 5% 50V NPO	Philips	
CD0101	C440	SMD capasitor	100 pF 5% 50 V NPO	Philips	
CD0104	C441	SMD capasitor	100 nF 10% 50 V X7R	Philips	
CD0220	C443	SMD capasitor	22 pF 5% 50 V NPO	Philips	
CD0220	C444	SMD capasitor	22 pF 5% 50 V NPO	Philips	
CH0105	C460	SMD capasitor	1uF/-20/+80%/16V	TaiyoYuden	EMK212 F105Z00T
CH0105	C461	SMD capasitor	1uF/-20/+80%/16V	TaiyoYuden	EMK212 F105Z00T
CU0225	C462	SMD tantal	2.2uF/16V 20% 4.7x2.6mm	Matsushita	ECST1CB 225R
CU1106	C463	SMD tantal	10uF/16V	AVX	TAJB106M016R
CD0104	C464	SMD capasitor	100 nF 10% 50 V X7R	Philips	
CE0337	C465	Al elko	330uF/16V 20% 15x8mm	Philips	222213555331
CE0476	C466	Al elko	47 uF/25 V 7x7mm	Philips	2222 097 56479
CE0337	C467	Al elko	330uF/16V 20% 15x8mm	Philips	222213555331
CD0104	C468	SMD capasitor	100 nF 10% 50 V X7R	Philips	
CD0103	C469	SMD capasitor	10 nF 10% 50 V X7R	Philips	
CD0103	C470	SMD capasitor	10 nF 10% 50 V X7R	Philips	
CD0103	C471	SMD capasitor	10 nF 10% 50 V X7R	Philips	
CD0471	C473	SMD capasitor	470 pF 5% 50 V NPO	Philips	
CU0105	C480	SMD tantal	1uF/16V 20% 3.2x1.6mm	Matsushita	ECST1CY 105R
CE3106	C501	Al-elko	10uF/63V +20% 11x5mm	Panasonic	ECEA1JU100
CD0101	C510	SMD capasitor	100 pF 5% 50 V NPO	Philips	
CD0471	C511	SMD capasitor	470 pF 5% 50 V NPO	Philips	
CD0104	C512	SMD capasitor	100 nF 10% 50 V X7R	Philips	
CD0104	C513	SMD capasitor	100 nF 10% 50 V X7R	Philips	
CP0155	C514	Polyester cap	1.5uF 20% 50V	Roerredstei	MKT 1826-515/05
CP0155	C515	Polyester cap	1.5uF 20% 50V	Roerredstei	MKT 1826-515/05

CODE	PART	DESCRIPT.	VALUE	MANUF.	TYPE
CD0101	C516	SMD capasitor	100 pF 5% 50 V NP0	Philips	
CE0476	C520	Al elko	47 uF/25 V 7x7mm	Philips	2222 097 56479
CD0101	C521	SMD capasitor	100 pF 5% 50 V NP0	Philips	
CD0104	C522	SMD capasitor	100 nF 10% 50 V X7R	Philips	
CP0155	C530	Polyester cap	1.5uF 20% 50V	Roerdestei	MKT 1826-515/05
CE3106	C531	Al-elko	10uF/63V +-20% 11x5mm	Panasonic	ECEA1JU100
CE0127	C534	Al elko	120uF/16V 6.3x11,5	NCC	SXE16VB120MJF11
CE0476	C535	Al elko	47 uF/25 V 7x7mm	Philips	2222 097 56479
CD0103	C540	SMD capasitor	10 nF 10% 50 V X7R	Philips	
CD0101	C541	SMD capasitor	100 pF 5% 50 V NP0	Philips	
CD0103	C550	SMD capasitor	10 nF 10% 50 V X7R	Philips	
CD0101	C551	SMD capasitor	100 pF 5% 50 V NP0	Philips	
CE3106	C560	Al-elko	10uF/63V +-20% 11x5mm	Panasonic	ECEA1JU100
CD0103	C561	SMD capasitor	10 nF 10% 50 V X7R	Philips	
CH0105	C580	SMD capasitor	1uF/-20/+80%/16V	TaiyoYuden	EMK212 F105Z00T
DT0033	D100	SMD Transient filter	33V/1500W	SGS-Thomso	SM15T33A
DZ0180	D200	SMD zener	18V 5% 300mW	Philips	BZX84C18
DT0033	D230	SMD Transient filter	33V/1500W	SGS-Thomso	SM15T33A
DT0033	D240	SMD Transient filter	33V/1500W	SGS-Thomso	SM15T33A
DS0056	D510	SMD diode pair	70V/100mA common anode	Philips	BAW 56
DY0045	D530	Shottky diode	45V/10A	I&R	10TQ045
DS0056	D531	SMD diode pair	70V/100mA common anode	Philips	BAW 56
DT0008	D533	SMD Trans zorb	8V/44A/600W	Motorola	1SMB8.0AT3
DS0099	D560	SMD diode	70 V 200 mA	Philips	BAV 99
DS0099	D570	SMD diode	70 V 200 mA	Philips	BAV 99
DS0056	D580	SMD diode pair	70V/100mA common anode	Philips	BAW 56
IR1317	I200	Adjustable regulator	1.2-37V 1.5A	National S	LM317AT
IR2952	I210	Regulator	100mA 5V adj. 0.5%	Micrel	MIC2951-02BM
000000	I211	*** EI KOODATTU VARAS-TOON ***			
II8574	I220	8 bit I/O	I2C	Philips	PCF8574T
IA7550	I300	Single op.amp.		Toshiba	TA 75S01F-TE85L
IC0453	I320	SMD 2x multip./demultip.		Toshiba	TC4W53F-TE 12L
IA7550	I321	Single op.amp.		Toshiba	TA 75S01F-TE85L
IC0453	I322	SMD 2x multip./demultip.		Toshiba	TC4W53F-TE 12L
IA7550	I330	Single op.amp.		Toshiba	TA 75S01F-TE85L
IA1905	I410	Audio power amplifier	5W/20V/4ohm	SGS-Thomso	TDA1905
IC0453	I430	SMD 2x multip./demultip.		Toshiba	TC4W53F-TE 12L
IC0453	I431	SMD 2x multip./demultip.		Toshiba	TC4W53F-TE 12L
IA7550	I440	Single op.amp.		Toshiba	TA 75S01F-TE85L
IA1905	I460	Audio power amplifier	5W/20V/4ohm	SGS-Thomso	TDA1905
IX0555	I520	Timer	Pipolar	Philips	SA555D
IO0172	I521	Optocoupler		Siemens	CNY17-2
IA2902	I540	Low power quar op-amp.		NationalSe	LM2902M
LA3117	L100	Inductor	110uH 3A R=0.07ohm	Fuji	SL03B111BE
LF0102	L400	SMD EMIFIL		Murata	BLM21A102FPT
LF0102	L440	SMD EMIFIL		Murata	BLM21A102FPT
LF0101	L460	SMD line filter		TaiyoYuden	FBM3216HS101T
LF0101	L461	SMD line filter		TaiyoYuden	FBM3216HS101T
LF0101	L462	SMD line filter		TaiyoYuden	FBM3216HS101T
LA1391	L501	Choke horizontal	90uH +-10%	Trafocomp	TJ1391
LA1391	L530	Choke horizontal	90uH +-10%	Trafocomp	TJ1391
QF9024	Q200	SMD p-channel FET	60V 9A Rds=0.28	I&R	IRFR9024TR
QF7002	Q201	SMD n-channel FET	60V 0.115A Rds7.5	Siliconix	2N7002-T1
QSB858	Q230	SMD transistor	PNP 0.1A/30V F<10dB	Philips	BC 858 B
QS1054	Q231	SMD transistor	NPN 1.5A/45V	Philips	BCP 54

CODE	PART	DESCRIPT.	VALUE	MANUF.	TYPE
QSB858	Q240	SMD transistor	PNP 0.1A/30V F<10dB	Philips	BC 858 B
QS1054	Q241	SMD transistor	NPN 1.5A/45V	Philips	BCP 54
QSB848	Q400	SMD transistor	NPN 0.1A/30V F=2dB	Philips	BC 848 B
QF7002	Q401	SMD n-channel FET	60V 0.115A Rds7.5	Siliconix	2N7002-T1
QSB848	Q402	SMD transistor	NPN 0.1A/30V F=2dB	Philips	BC 848 B
QSB848	Q450	SMD transistor	NPN 0.1A/30V F=2dB	Philips	BC 848 B
QSB848	Q510	SMD transistor	NPN 0.1A/30V F=2dB	Philips	BC 848 B
QSB858	Q511	SMD transistor	PNP 0.1A/30V F<10dB	Philips	BC 858 B
QF7002	Q512	SMD n-channel FET	60V 0.115A Rds7.5	Siliconix	2N7002-T1
QF0124	Q513	N-channel fet	55V/17A Rds=0.07	I&R	IRFZ24N
QF0124	Q514	N-channel fet	55V/17A Rds=0.07	I&R	IRFZ24N
QSB848	Q560	SMD transistor	NPN 0.1A/30V F=2dB	Philips	BC 848 B
QSB848	Q561	SMD transistor	NPN 0.1A/30V F=2dB	Philips	BC 848 B
QSB858	Q570	SMD transistor	PNP 0.1A/30V F<10dB	Philips	BC 858 B
QSB858	Q571	SMD transistor	PNP 0.1A/30V F<10dB	Philips	BC 858 B
RD0101	R100	SMD resistor	100 R 5% 0.125 W	Kamaya	
RD0101	R101	SMD resistor	100 R 5% 0.125 W	Kamaya	
RD0224	R200	SMD resistor	220 k 5% 0.125 W	Kamaya	
RD0103	R201	SMD resistor	10 k 5% 0.125 W	Kamaya	
RD0104	R202	SMD resistor	100 k 5% 0.125 W	Kamaya	
RD0103	R203	SMD resistor	10 k 5% 0.125 W	Kamaya	
RD0152	R204	SMD resistor	1.5 k 5% 0.125 W	Kamaya	
RD1241	R205	SMD resistor	240R 1% 0.125 W	Kamaya	RGC 1/10
RD0103	R210	SMD resistor	10 k 5% 0.125 W	Kamaya	
RD1123	R211	SMD resistor	12 k 1% 0.125 W	KOA	
RD1682	R212	SMD resistor	6.8 k 1% 0.125 W	KOA	
RD0101	R220	SMD resistor	100 R 5% 0.125 W	Kamaya	
RD0101	R221	SMD resistor	100 R 5% 0.125 W	Kamaya	
RD0472	R230	SMD resistor	4.7 k 5% 0.125 W	Kamaya	
RD0561	R231	SMD resistor	560 R 5% 0.125 W	Kamaya	
RD0103	R232	SMD resistor	10 k 5% 0.125 W	Kamaya	
RD0472	R240	SMD resistor	4.7 k 5% 0.125 W	Kamaya	
RD0561	R241	SMD resistor	560 R 5% 0.125 W	Kamaya	
RD0103	R242	SMD resistor	10 k 5% 0.125 W	Kamaya	
RD0222	R300	SMD resistor	2.2 k 5% 0.125 W	Kamaya	
RD0102	R301	SMD resistor	1 k 5% 0.125 W	Kamaya	
RD0223	R302	SMD resistor	22 k 5% 0.125 W	Kamaya	
RD0224	R303	SMD resistor	220 k 5% 0.125 W	Kamaya	
RD0153	R304	SMD resistor	15 k 5% 0.125 W	Kamaya	
RD0103	R305	SMD resistor	10 k 5% 0.125 W	Kamaya	
RD0103	R306	SMD resistor	10 k 5% 0.125 W	Kamaya	
RD0333	R307	SMD resistor	33 k 5% 0.125 W	Kamaya	
RD0224	R320	SMD resistor	220 k 5% 0.125 W	Kamaya	
RD0103	R321	SMD resistor	10 k 5% 0.125 W	Kamaya	
RD0224	R322	SMD resistor	220 k 5% 0.125 W	Kamaya	
RD0103	R323	SMD resistor	10 k 5% 0.125 W	Kamaya	
RD0102	R324	SMD resistor	1 k 5% 0.125 W	Kamaya	
RD0222	R330	SMD resistor	2.2 k 5% 0.125 W	Kamaya	
RD0102	R331	SMD resistor	1 k 5% 0.125 W	Kamaya	
RD0183	R332	SMD resistor	18 k 5% 0.125 W	Kamaya	
RD0224	R333	SMD resistor	220 k 5% 0.125 W	Kamaya	
RD0153	R334	SMD resistor	15 k 5% 0.125 W	Kamaya	
RD0103	R335	SMD resistor	10 k 5% 0.125 W	Kamaya	
RD0103	R336	SMD resistor	10 k 5% 0.125 W	Kamaya	
RD0333	R337	SMD resistor	33 k 5% 0.125 W	Kamaya	
RD0104	R340	SMD resistor	100 k 5% 0.125 W	Kamaya	
RD0473	R341	SMD resistor	47 k 5% 0.125 W	Kamaya	
RD0473	R400	SMD resistor	47 k 5% 0.125 W	Kamaya	
RD0104	R401	SMD resistor	100 k 5% 0.125 W	Kamaya	
RD0563	R402	SMD resistor	56 k 5% 0.125 W	Kamaya	

CODE	PART	DESCRIPT.	VALUE	MANUF.	TYPE
RD0563	R403	SMD resistor	56 k 5% 0.125 W	Kamaya	
RD0333	R404	SMD resistor	33 k 5% 0.125 W	Kamaya	
RD0103	R405	SMD resistor	10 k 5% 0.125 W	Kamaya	
RD0222	R407	SMD resistor	2.2 k 5% 0.125 W	Kamaya	
LF0102	R408	SMD EMIFIL		Murata	BLM21A102FPT
LF0102	R409	SMD EMIFIL		Murata	BLM21A102FPT
RD0101	R410	SMD resistor	100 R 5% 0.125 W	Kamaya	
RD0103	R411	SMD resistor	10 k 5% 0.125 W	Kamaya	
RD0339	R412	SMD resistor	3.3 R 5% 0.125 W	Kamaya	
RD0561	R413	SMD resistor	560 R 5% 0.125 W	Kamaya	
RD0102	R414	SMD resistor	1 k 5% 0.125 W	Kamaya	
RD0273	R415	SMD resistor	27 k 5% 0.125 W	Kamaya	
RD0104	R416	SMD resistor	100 k 5% 0.125 W	Kamaya	
RD0333	R430	SMD resistor	33 k 5% 0.125 W	Kamaya	
RD0333	R431	SMD resistor	33 k 5% 0.125 W	Kamaya	
RD0333	R432	SMD resistor	33 k 5% 0.125 W	Kamaya	
RD0104	R440	SMD resistor	100 k 5% 0.125 W	Kamaya	
RD0104	R441	SMD resistor	100 k 5% 0.125 W	Kamaya	
RD0473	R442	SMD resistor	47 k 5% 0.125 W	Kamaya	
RD0103	R443	SMD resistor	10 k 5% 0.125 W	Kamaya	
RD0473	R450	SMD resistor	47 k 5% 0.125 W	Kamaya	
RD0103	R451	SMD resistor	10 k 5% 0.125 W	Kamaya	
RD0223	R460	SMD resistor	22 k 5% 0.125 W	Kamaya	
RD0102	R461	SMD resistor	1 k 5% 0.125 W	Kamaya	
RD0223	R462	SMD resistor	22 k 5% 0.125 W	Kamaya	
RD0101	R463	SMD resistor	100 R 5% 0.125 W	Kamaya	
RD0103	R464	SMD resistor	10 k 5% 0.125 W	Kamaya	
RD0561	R465	SMD resistor	560 R 5% 0.125 W	Kamaya	
RD0339	R466	SMD resistor	3.3 R 5% 0.125 W	Kamaya	
RD0104	R480	SMD resistor	100 k 5% 0.125 W	Kamaya	
RD0473	R481	SMD resistor	47 k 5% 0.125 W	Kamaya	
AF1101	R501	SMT chip fuse	1A/32V	Bussmann	TR3216FF-1A
RD0332	R510	SMD resistor	3.3 k 5% 0.125 W	Kamaya	
RD0103	R511	SMD resistor	10 k 5% 0.125 W	Kamaya	
RD0683	R520	SMD resistor	68 k 5% 0.125 W	Kamaya	
RD0560	R530	SMD resistor	56 R 5% 0.125 W	Kamaya	
RD0471	R540	SMD resistor	470 R 5% 0.125 W	Kamaya	
RD0103	R541	SMD resistor	10 k 5% 0.125 W	Kamaya	
RD0223	R542	SMD resistor	22 k 5% 0.125 W	Kamaya	
RD0333	R543	SMD resistor	33 k 5% 0.125 W	Kamaya	
RC0189	R544	SMD resistor	1R8 5% 0.125 W	Kamaya	
RC0189	R545	SMD resistor	1R8 5% 0.125 W	Kamaya	
RC0189	R546	SMD resistor	1R8 5% 0.125 W	Kamaya	
RD0333	R547	SMD resistor	33 k 5% 0.125 W	Kamaya	
RD0185	R548	SMD resistor	1.8 M 5% 0.125 W	Kamaya	
RD0104	R549	SMD resistor	100 k 5% 0.125 W	Kamaya	
RD0333	R550	SMD resistor	33 k 5% 0.125 W	Kamaya	
RD0473	R551	SMD resistor	47 k 5% 0.125 W	Kamaya	
RD0333	R552	SMD resistor	33 k 5% 0.125 W	Kamaya	
RD0393	R553	SMD resistor	39 k 5% 0.125 W	Kamaya	
RD0333	R554	SMD resistor	33 k 5% 0.125 W	Kamaya	
RD0105	R555	SMD resistor	1 M 5% 0.125 W	Kamaya	
RD0103	R556	SMD resistor	10 k 5% 0.125 W	Kamaya	
RD0185	R557	SMD resistor	1.8 M 5% 0.125 W	Kamaya	
RD0104	R560	SMD resistor	100 k 5% 0.125 W	Kamaya	
RD0333	R561	SMD resistor	33 k 5% 0.125 W	Kamaya	
RD0223	R562	SMD resistor	22 k 5% 0.125 W	Kamaya	
RD0103	R570	SMD resistor	10 k 5% 0.125 W	Kamaya	
RD0103	R571	SMD resistor	10 k 5% 0.125 W	Kamaya	
RD0185	R572	SMD resistor	1.8 M 5% 0.125 W	Kamaya	

CODE	PART	DESCRIPT.	VALUE	MANUF.	TYPE
RD0333	R573	SMD resistor	33 k 5% 0.125 W	Kamaya	
RD0103	R574	SMD resistor	10 k 5% 0.125 W	Kamaya	
RD0103	R575	SMD resistor	10 k 5% 0.125 W	Kamaya	
RD0153	R576	SMD resistor	15 k 5% 0.125 W	Kamaya	
RD0224	R577	SMD resistor	220 k 5% 0.125 W	Kamaya	
RD0104	R578	SMD resistor	100 k 5% 0.125 W	Kamaya	
RD0102	R579	SMD resistor	1 k 5% 0.125 W	Kamaya	
RD0104	R580	SMD resistor	100 k 5% 0.125 W	Kamaya	
RD0564	R581	SMD resistor	560 k 5% 0.125 W	Kamaya	
RD0104	R582	SMD resistor	100 k 5% 0.125 W	Kamaya	
RD0564	R583	SMD resistor	560 k 5% 0.125 W	Kamaya	
RD0102	R584	SMD resistor	1 k 5% 0.125 W	Kamaya	
RD0332	R585	SMD resistor	3.3 k 5% 0.125 W	Kamaya	
RD0221	R586	SMD resistor	220 R 5% 0.125 W	Kamaya	
LT0005	T530	Transformer			
VW0106	V100	Connector	male 6-pin	Molex	5569-06-A1
VN0003	V102	Modular jack	4-pin	AMP	215875-1
VN0005	V103	Stereo jack	3.5mm	Zupami	3.5 EJW-C386
VM0342	V104	SMD system connector	16 pin	AMP	338269-1
VM0116	V105	Contact strip angle	2x8	NB-electr.	H4-6-16G
LF0061	X100	SMD EMI suppression filt	4700pF/2A 1.6x6.8mm	Murata	NFM61R30T472
LF0061	X101	SMD EMI suppression filt	4700pF/2A 1.6x6.8mm	Murata	NFM61R30T472

Last
update
05.03.98

The Top Side Layout PW1951A1

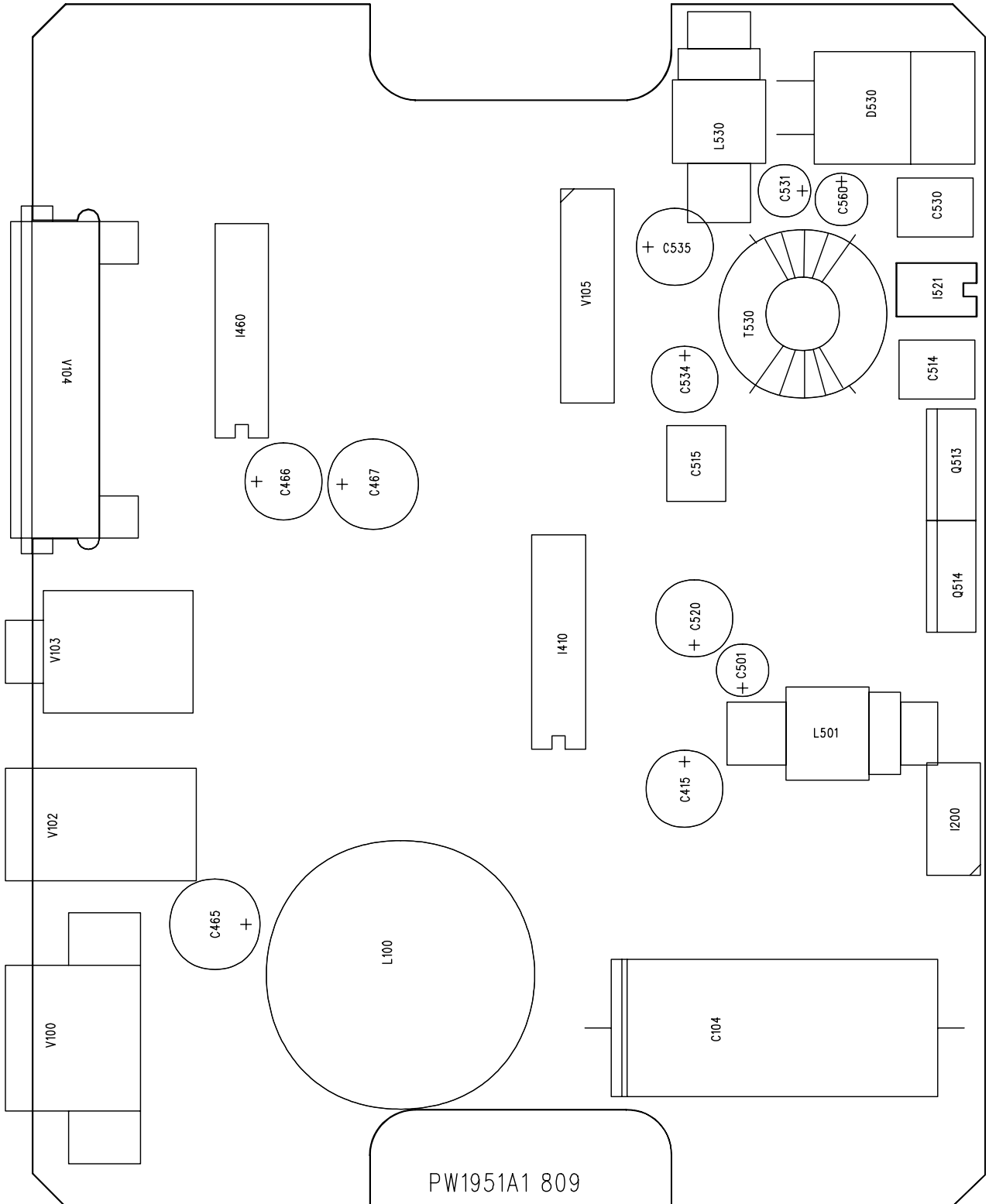

The Bottom Side Layout PW1951A1

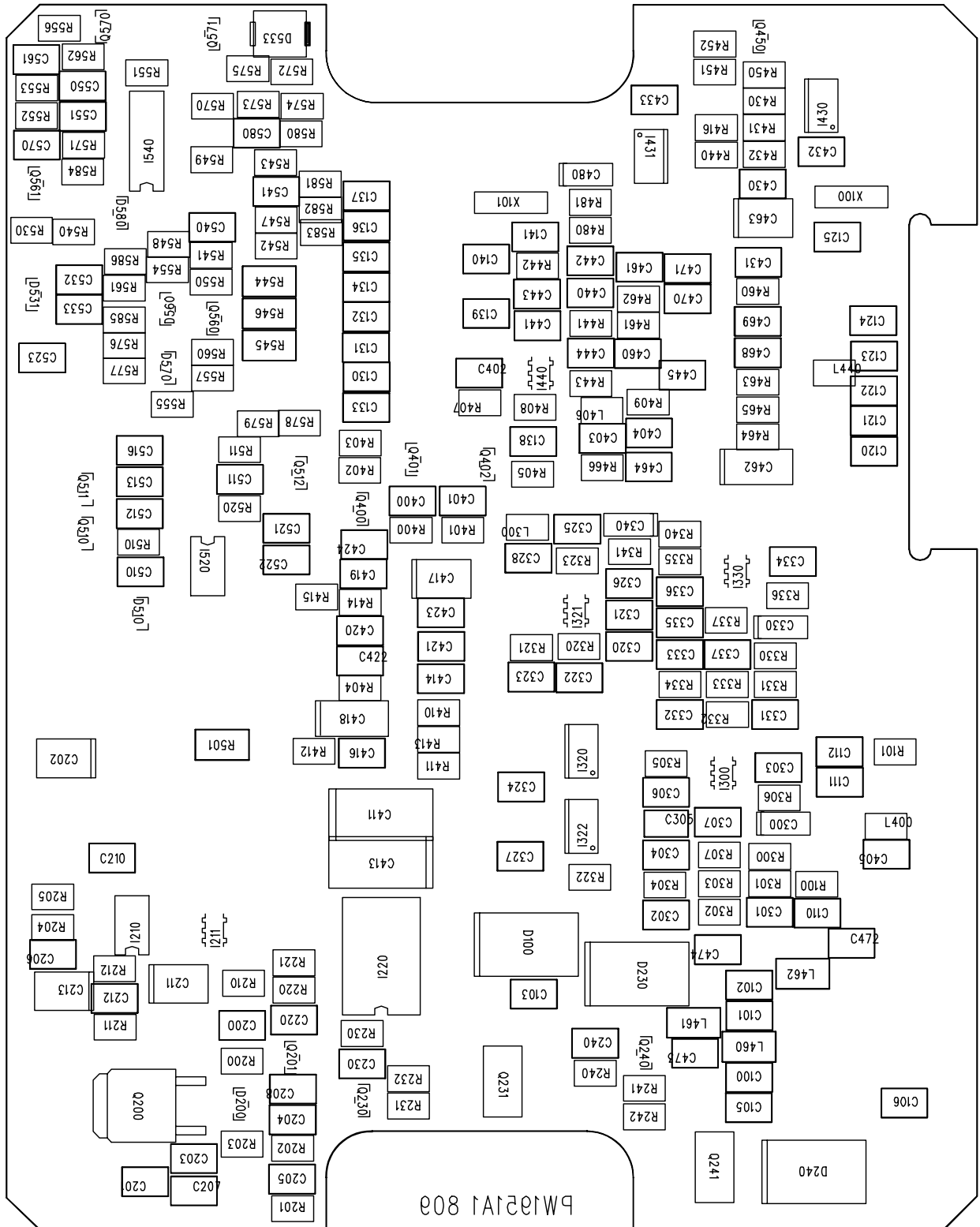

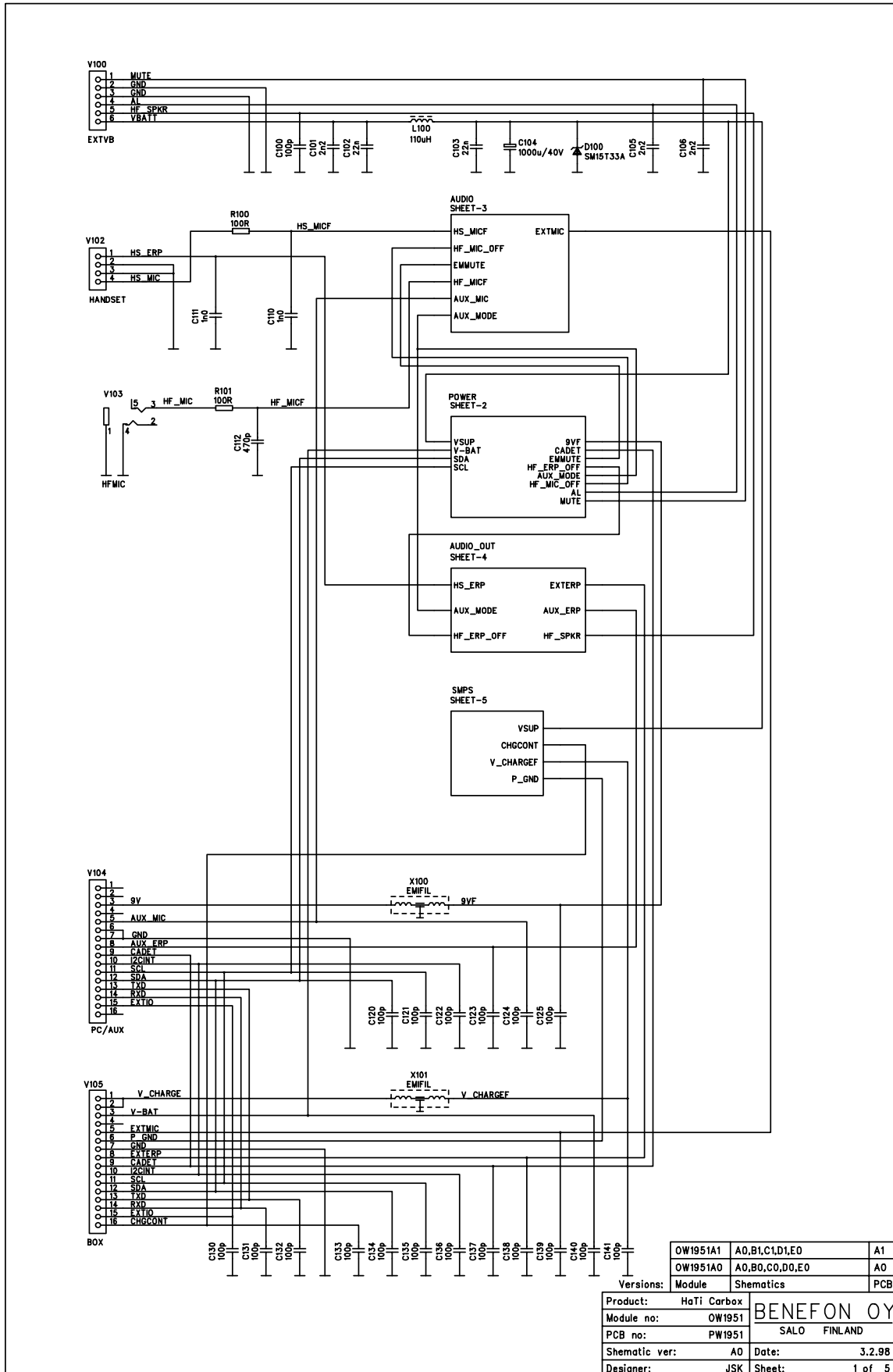

OW1951A1	A0,B1,C1,D1,E0	A1
OW1951A0	A0,B0,C0,D0,E0	A0
Product:	HaTi Carbox	BENEFON OY
Module no:	OW1951	
PCB no:	PW1951	SALO FINLAND
Schematic ver:	A0	Date: 3.2.98
Designer:	JSK	Sheet: 1 of 5

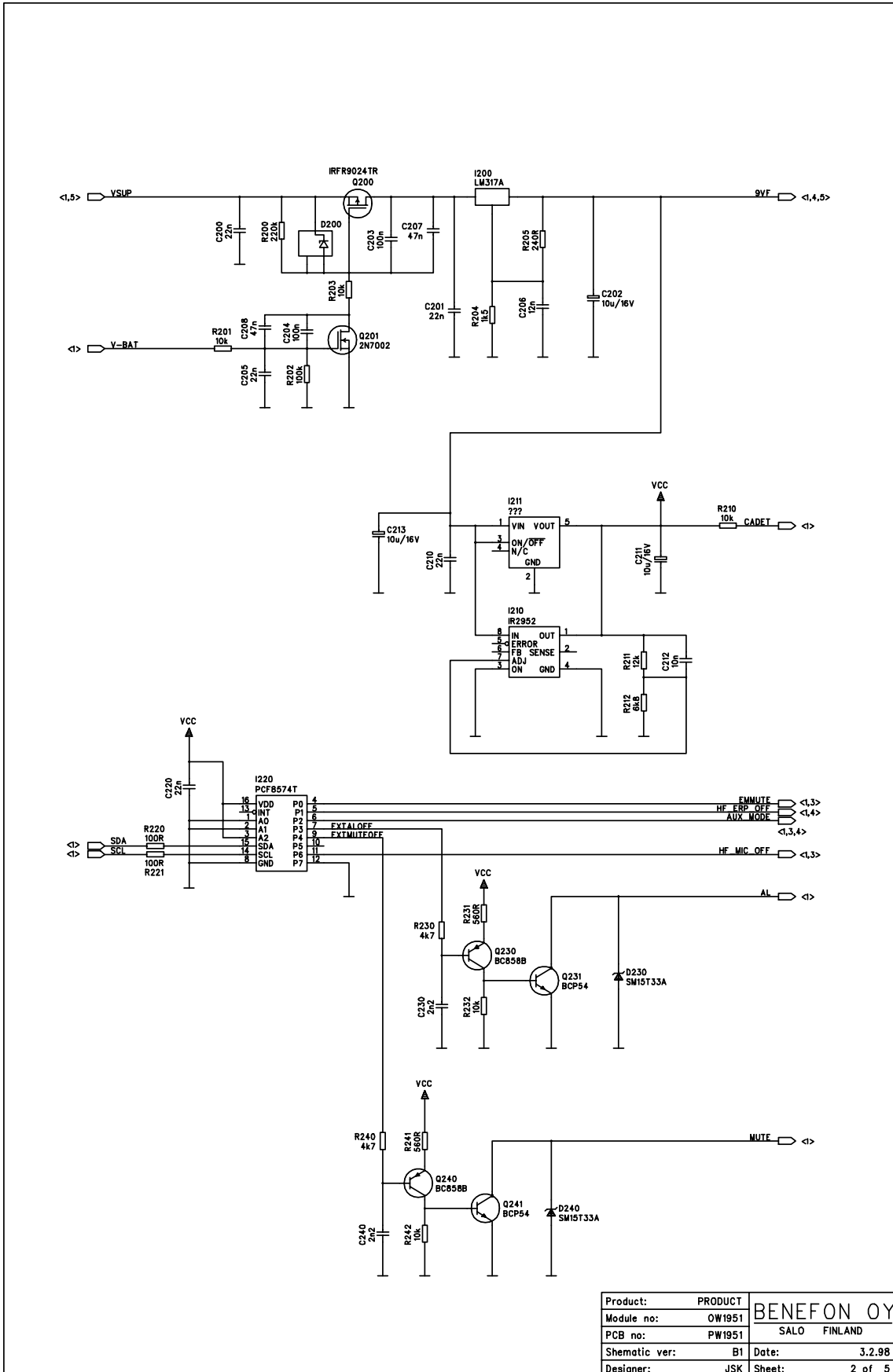

Product:	PRODUCT	BENEFON OY
Module no:	OW1951	
PCB no:	PW1951	SALO FINLAND
Schematic ver:	B1	Date: 3.2.98
Designer:	JSK	Sheet: 2 of 5

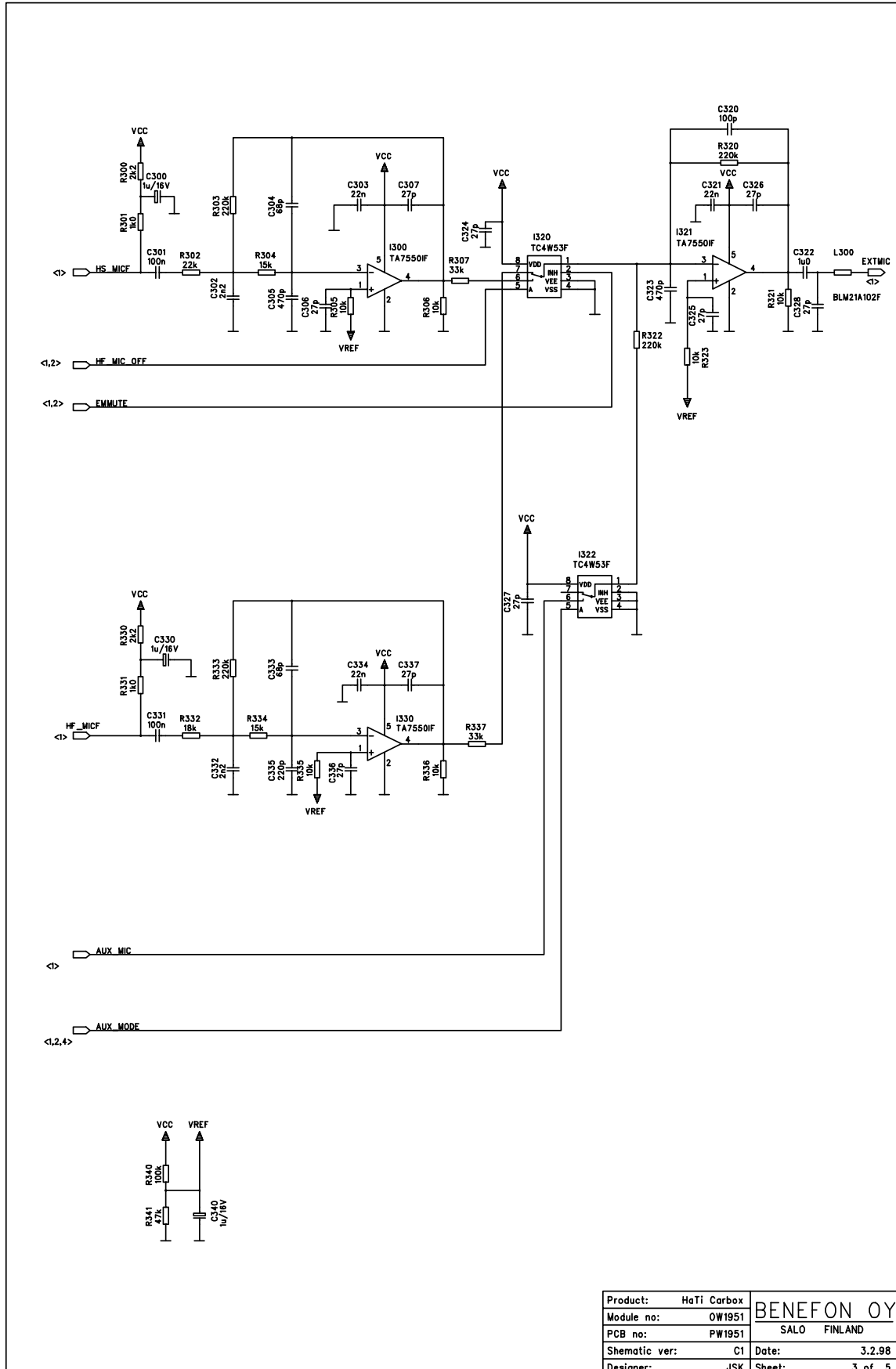

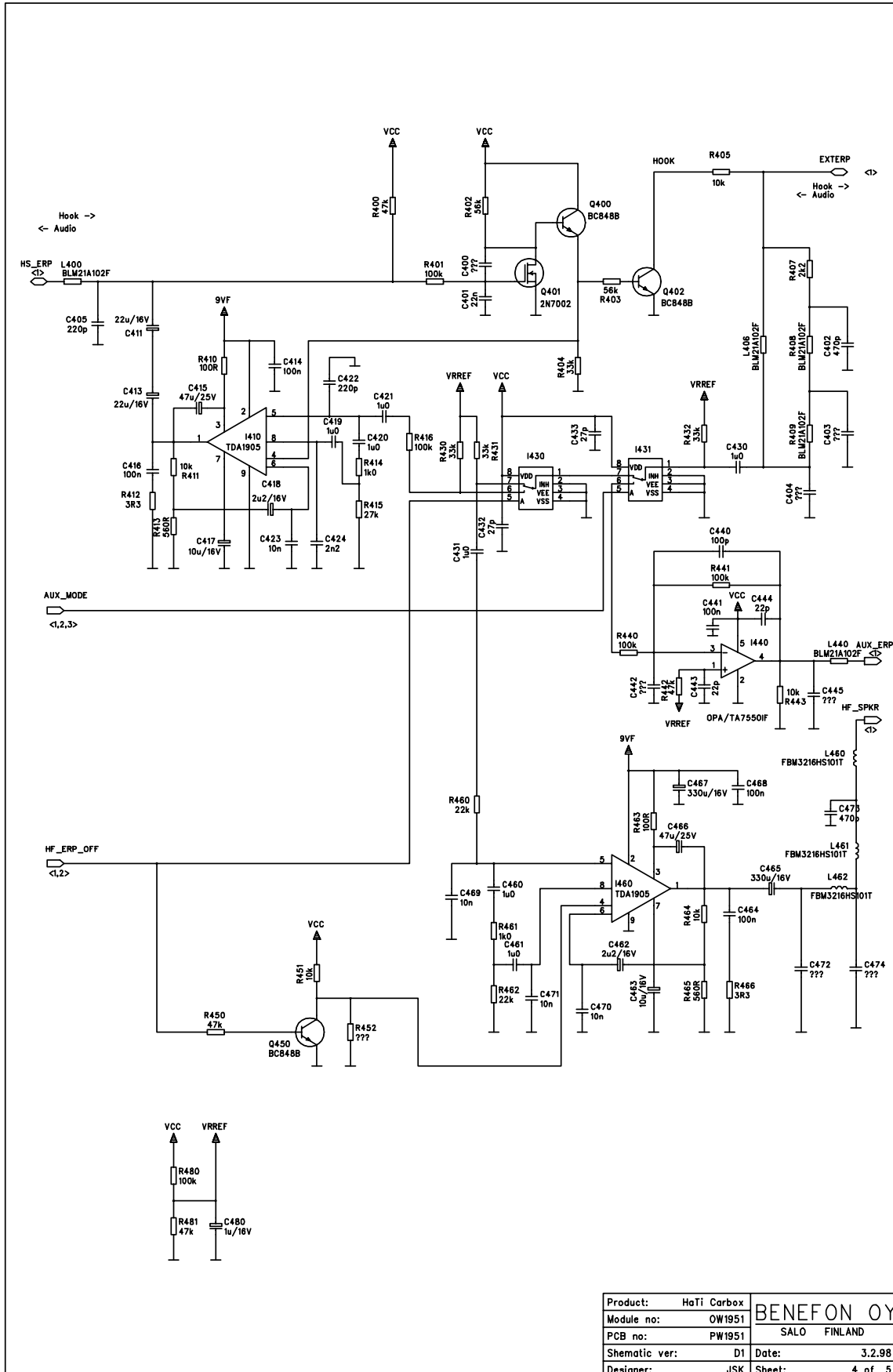

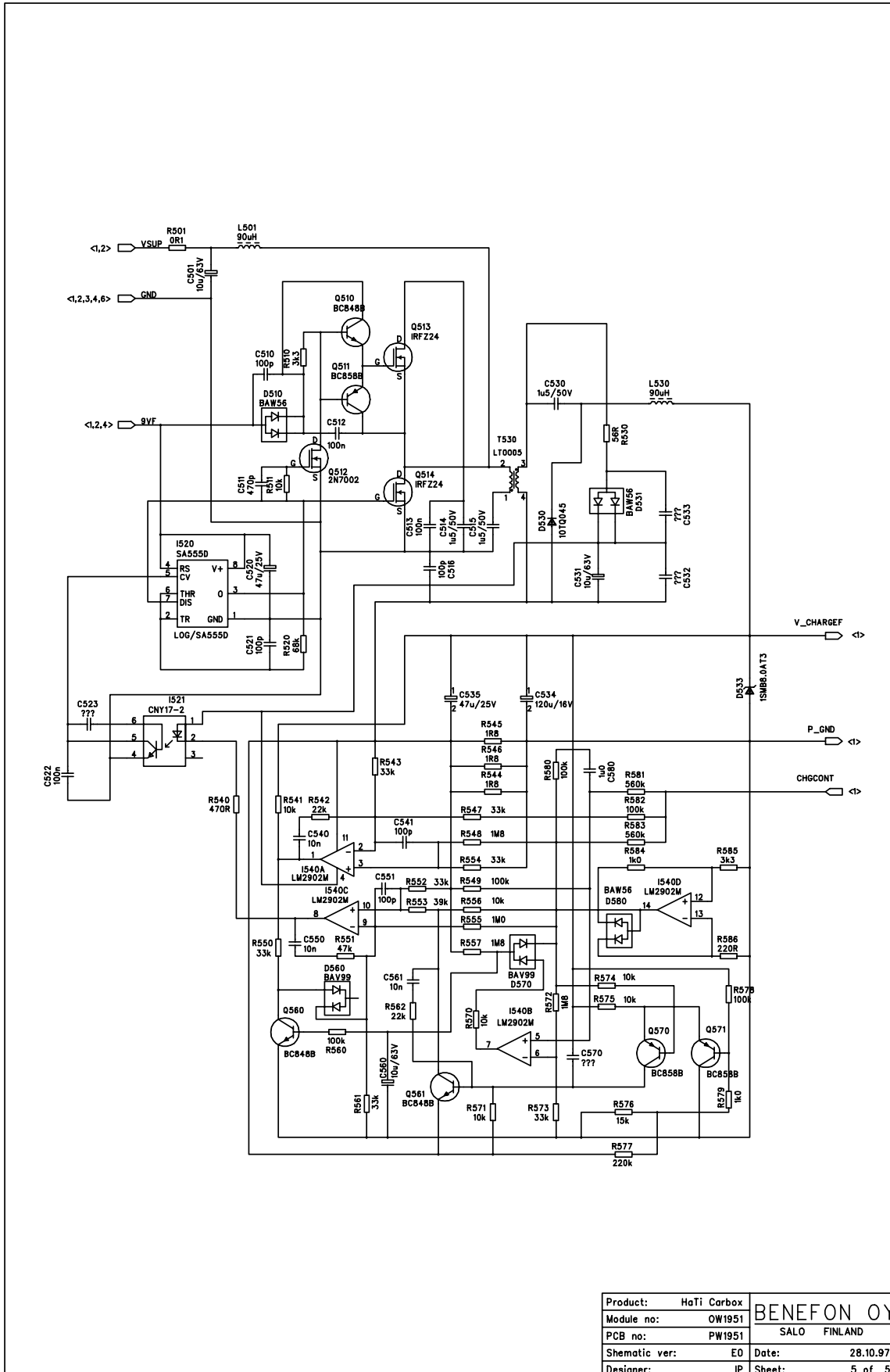

Product:	HaTi Carbox	BENEFON OY SALO FINLAND
Module no:	OW1951	
PCB no:	PW1951	
Schematic ver:	E0	
Designer:	IP	
Date:	28.10.97	Sheet: 5 of 5

YO1951 / Mechanics

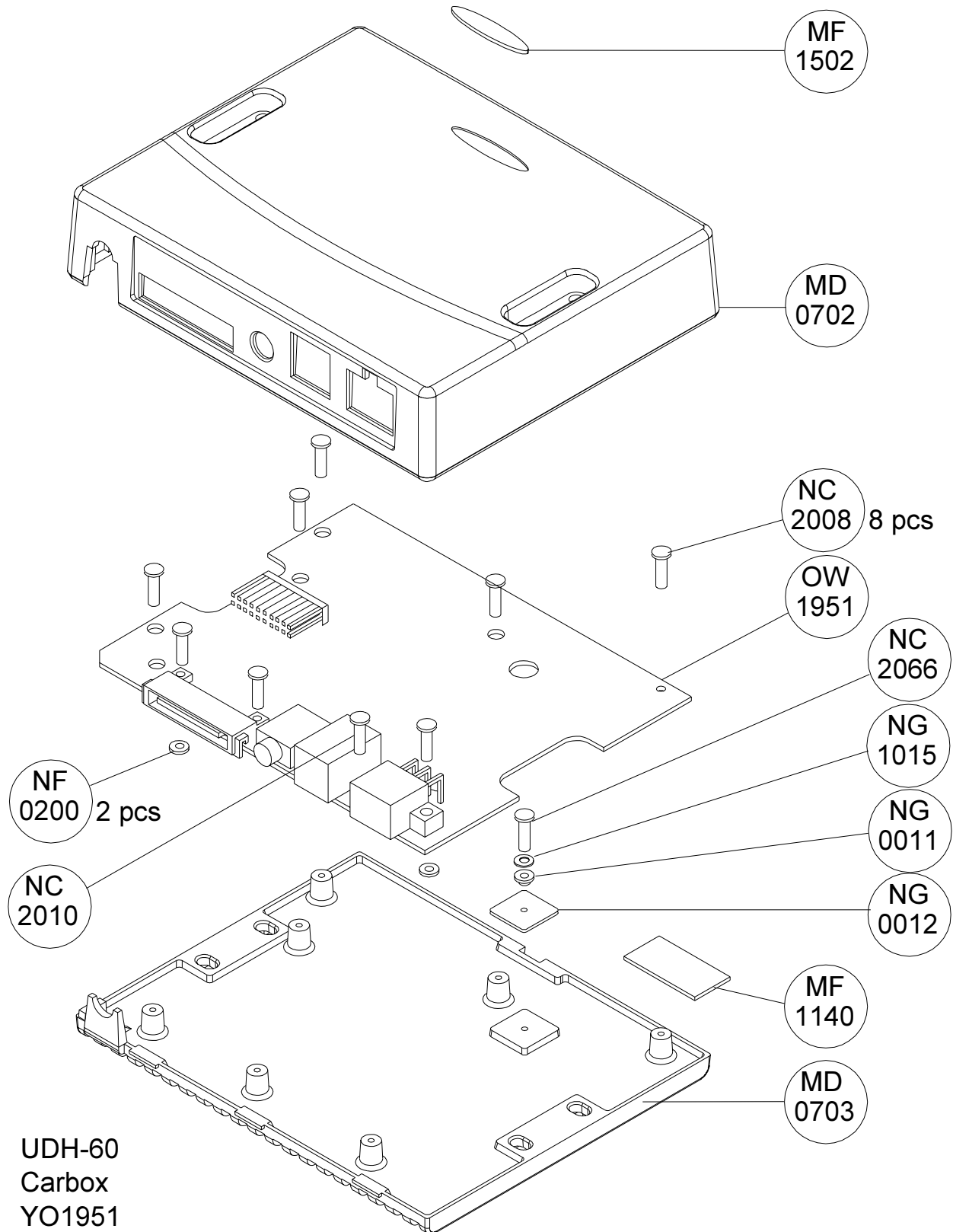

6.2 EXTERNAL HANDSET WITH CRADLE HDS-50

6.2.1 External Handset (not serviceable)

6.2.1.1 Mechanics

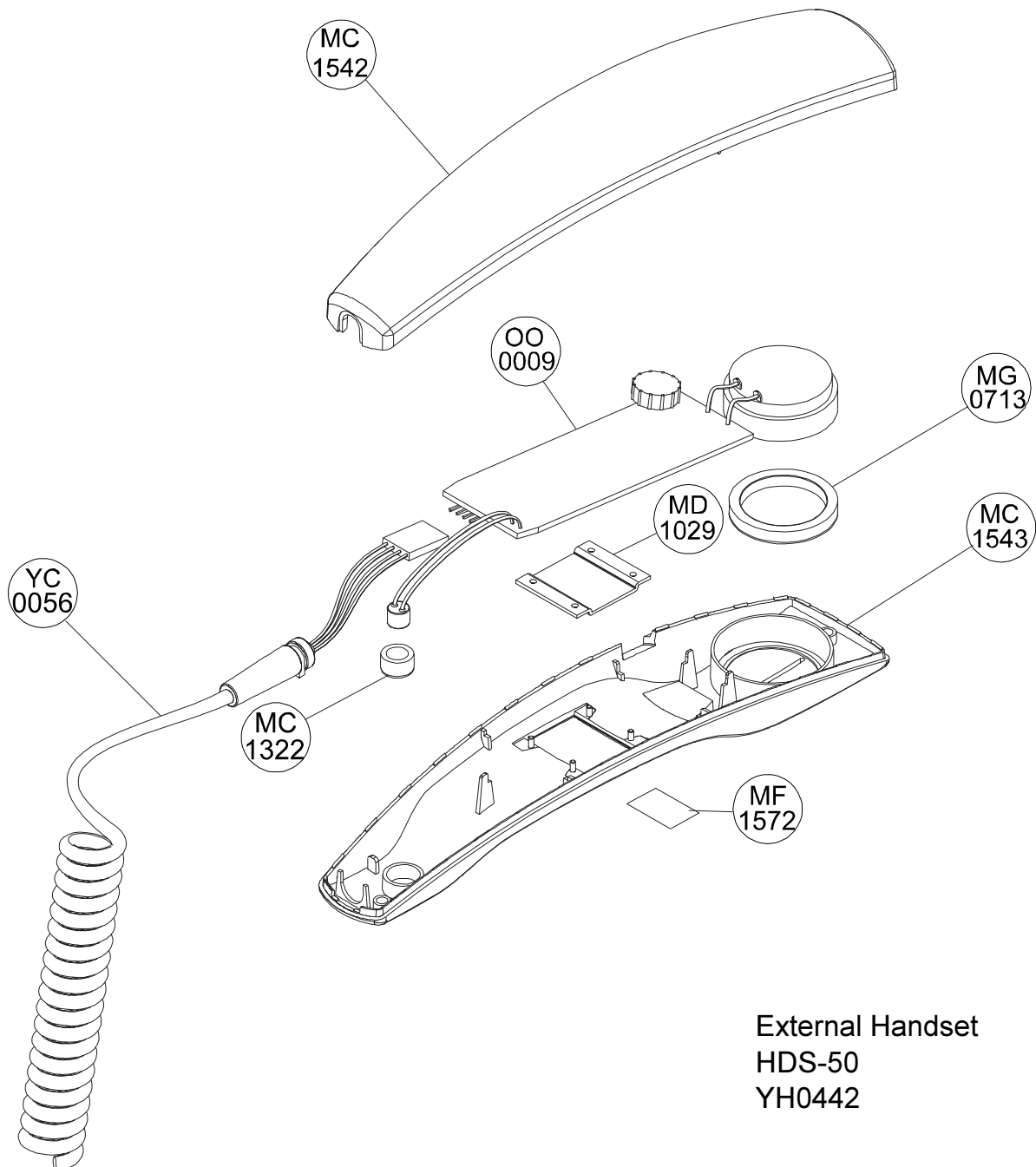

6.2.1.2 Cable

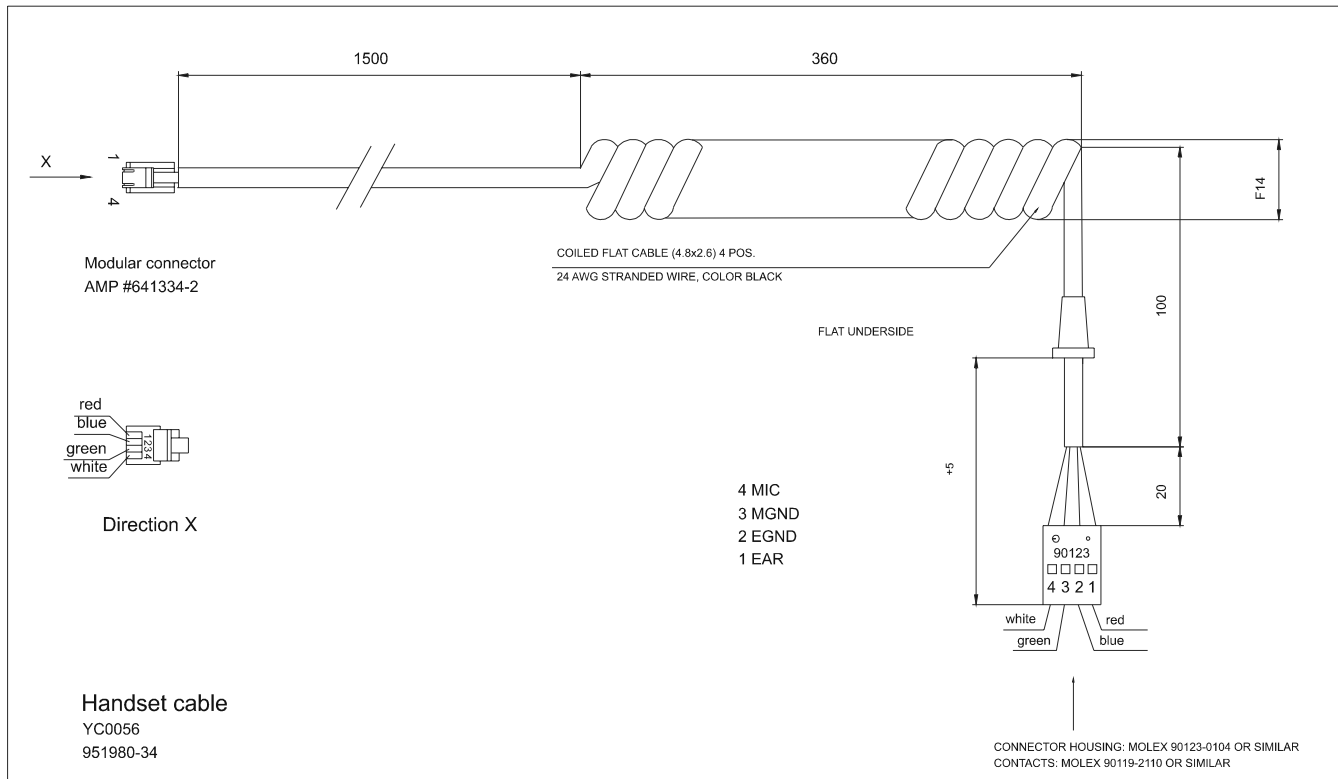

Outer Sheath

Material:

Coloured PVC
Black, BS 6748
TYPE TM2 and
BT M140C

Colour:

Matt

Length:

Finnish:

5 ±0,2 m

Total:

Coiled length:

3 ±0,2 m

Number of conductors:

4

Size:

AWG 26 stranded wire

Resistance:

< 100 mohm/m

Number of strands

Multiwire (30 x 0.08 mm
PCW)

Insulation material:

Coloured polypropylene

Strain relief:

Shall be firmly attached to
the cable

6.2.2 General

The external handset is designed for use together with the hands-free car kit. The external handset includes a microphone, an earphone and a reed switch. The handset kit contains a handset with a cable and a modular connector, a cradle, and mounting devices. A reed element shall be used to switch the audio signals to the handset when the handset is hooked off.

6.2.3 Connector XIN Signals

1	ERP	earphone input, HOOK state
2	GND	ground
3	GND	ground
4	MIC	microphone output

6.2.4 Microphone

Sensitivity:	-43 dB ± 6 dB
Vendor and part no:	Hosiden KUC2023 or KUB2023
RF decoupling capacitor:	33 pF; Size: 0805; Mounted on the microphone element.

6.2.5 Speaker

Sensitivity	95 dB ± 5 dB
Vendor and part no:	Hosiden KDR0928-IE-0030
Impedance:	min 120 ohm
Resistance (DC):	max 3 kohm

6.2.6 Hook

The hook operation is done by use of a reed switch. Hook operation is connected to the handset earphone terminal.

The operation is as follows:

ON_HOOK	HIGH DC IMPEDANCE (SWITCH OPEN)
OFF_HOOK	LOW DC IMPEDANCE (SWITCH CLOSED), 2.2 KOHM RESISTANCE

6.2.7 Parts list OO0009

CODE	PART	DESCRIPT.	VALUE	MANUF.	TYPE
CU0475	C106	SMD tantal	4.7uF/16V 20% 4.7X2.6MM	Matsushita	ECST1CB 475R
CD0221	C108	SMD capasitor	220 pF 5% 50 V NP0	Philips	
CD0221	C110	SMD capasitor	220 pF 5% 50 V NP0	Philips	
CD0221	C112	SMD capasitor	220 pF 5% 50 V NP0	Philips	
CD0221	C114	SMD capasitor	220 pF 5% 50 V NP0	Philips	
PO0009	M100	PCB for OO0900			
RP0222	R100	Edge control pot.	2.2k 0.1W LOG.	Ruwido	0037-006 2k2 log
RD0222	R102	SMD resistor	2.2 k 5% 0.125 W	Kamaya	
AR0016	S102	Reed-relay		Hamlin	59160-031
AE0018	XERP	Assembled earphone unit	150ohm/94-+3dB/60mW	Hoside	KDR0928-1E-0300
AM2024	XMIC	Assembled microphone unit	Electret condenser -43-+4dB	Hoside	KUB2023-030444SB
VM0204	XIN	Contact strip angle	1 x 4		

Last
update
16.05.97

The Top Side Layout PO0009A1 (Schematic OO0009A1)

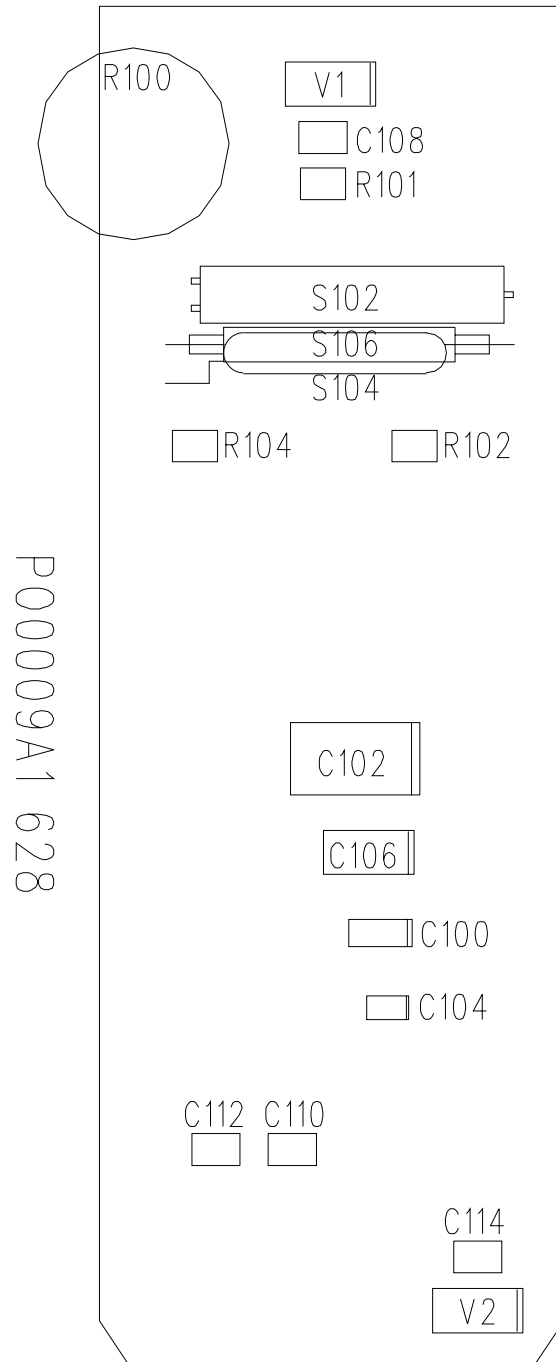

The Bottom Side Layout PO0009A1 (Schematic OO0009A1)

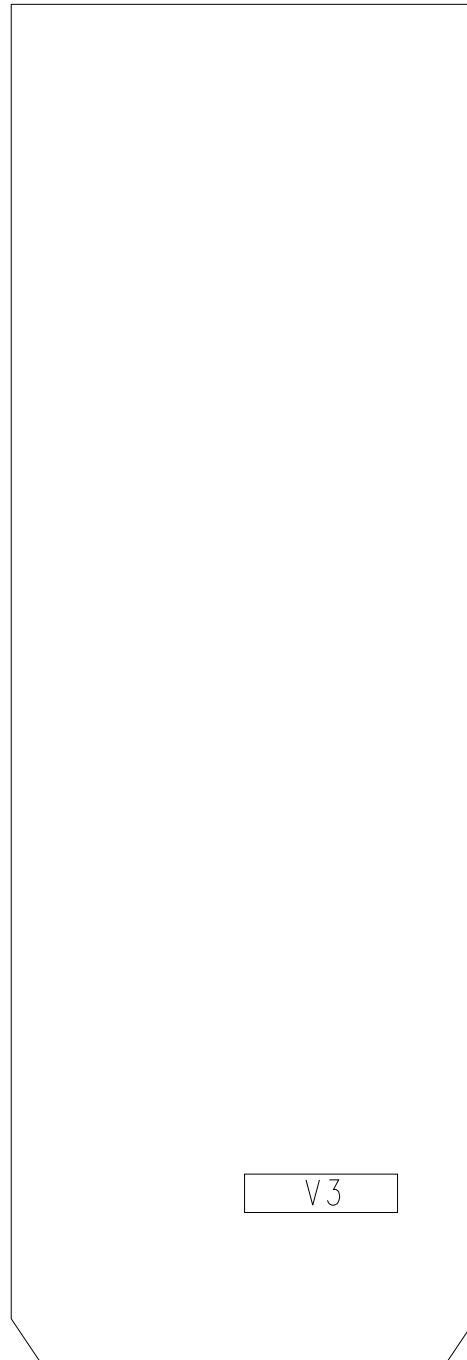

PO0009A1 058

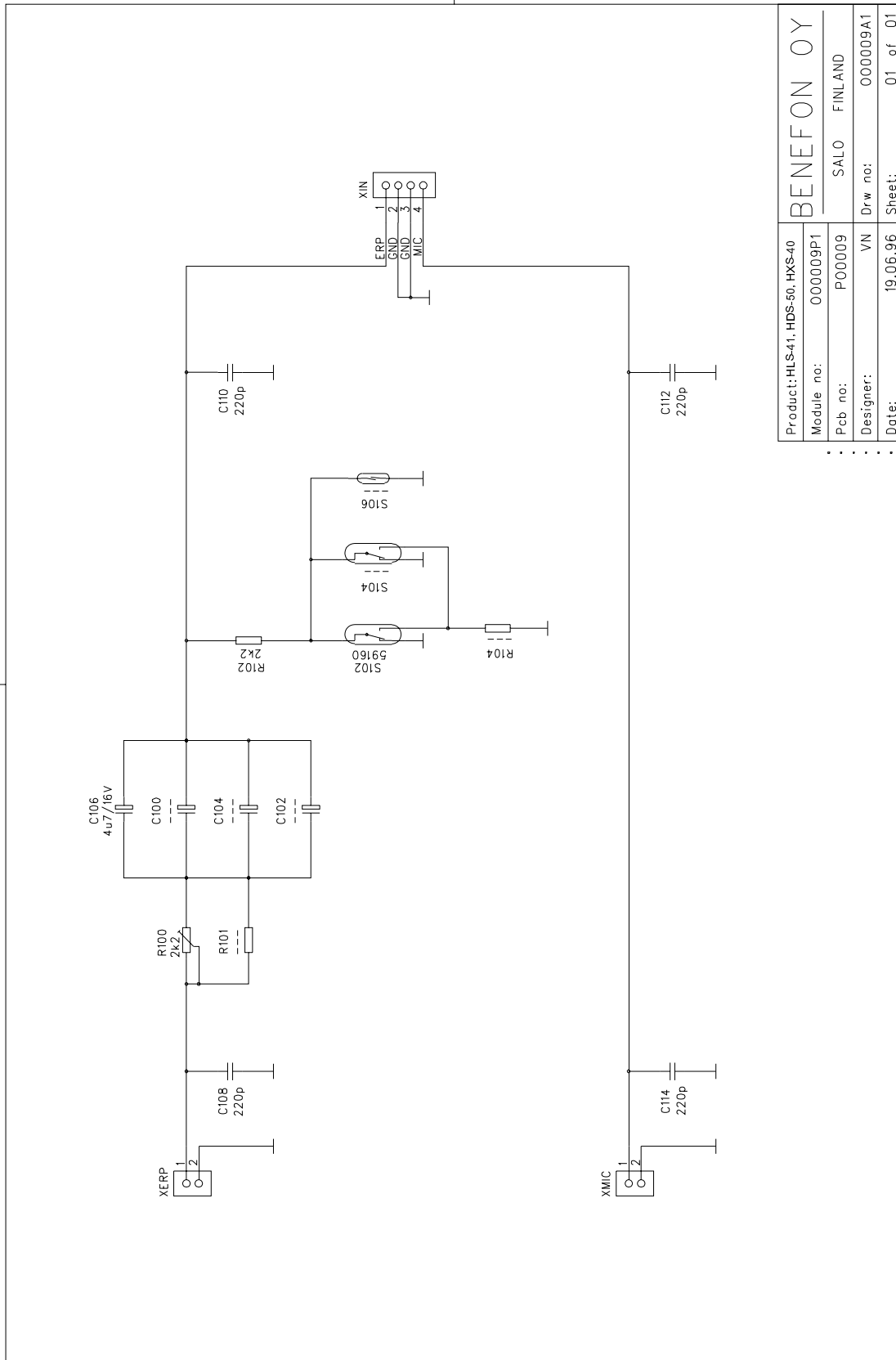

Product: HLS-41, HDS-50, HXS-40	
Module no:	000009P1
Pcb no:	P00009
Designer:	VN
Date:	19.06.96
BENEFON OY	
SALO FINLAND	
Draw no:	000009A1
Sheet:	01 of 01

6.2.8 Cradle

6.2.8.1 Mechanics

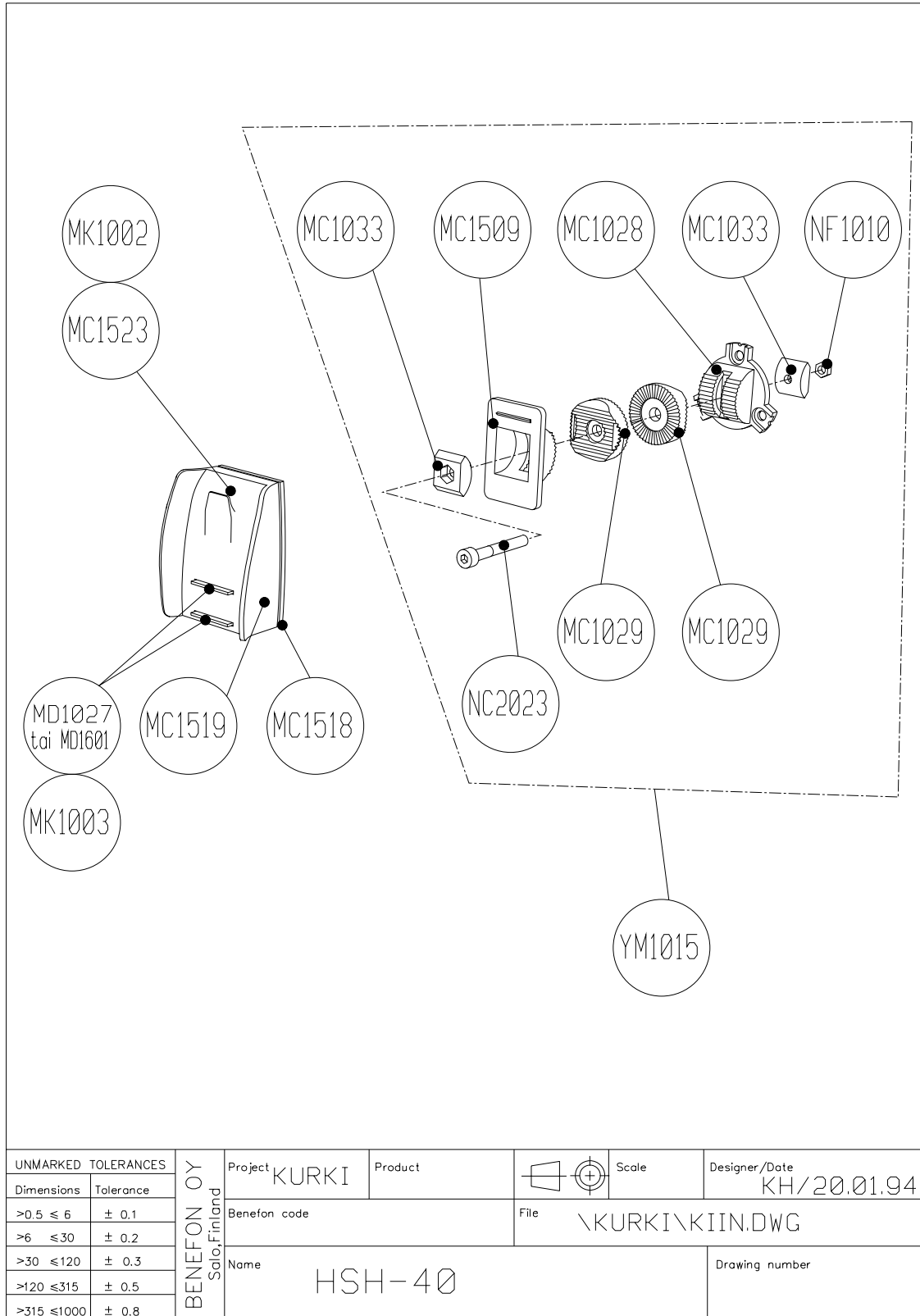

7.0 BENEBOOST

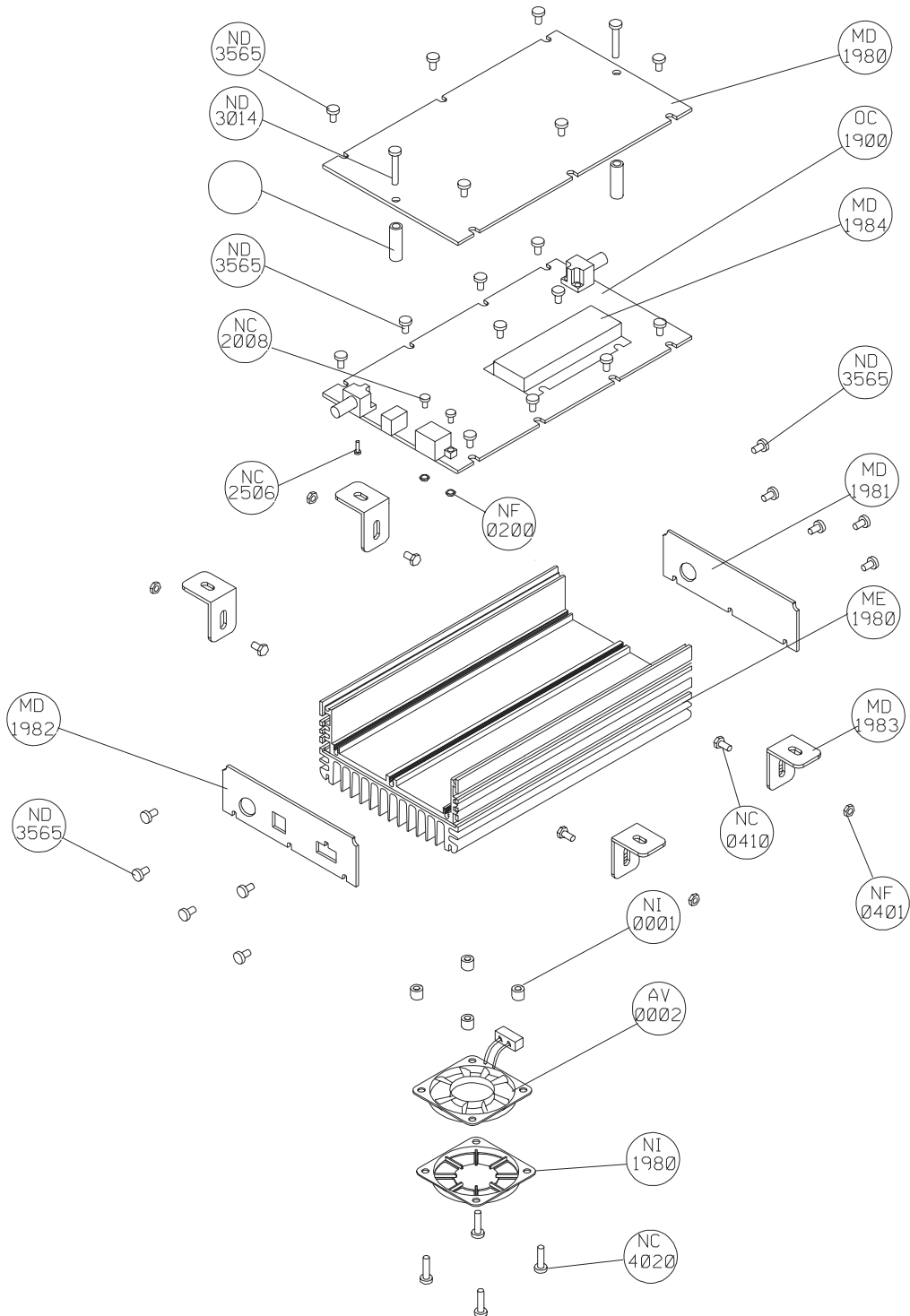

Booster			
Code	Country	Frequency band	Capacity
YO 1900	Malaysia	452.000-456.475MHz	15 W
YO 1910	Nordic, Bulgaria	453.000-457.475MHz	15 W
YO 1903	Hungary	455.230-459.990MHz	15 W
YO 1904	Slovenia, Croatia	411.675-415.850MHz	15 W
YO 1908	Thailand, Indonesia	479.000-483.480MHz	15 W
YO 1909	Poland	452.000-457.475MHz	7 W

7.0.1 TECHNICAL INFORMATION

Car amplifier for Benefon Spica/Titan NMT 450i HP

weight: 1190g

size (l x w x h): 190x110x60 mm

high power: 15 W

supply voltage: 10.8 - 15.6 V

power consumption

- charging off: app. 130 mA BeneBoost + car kit
- charging on: <1000 mA BeneBoost + car kit
- conversation mode, high power: <5000 mA BeneBoost + car kit

antenna connectors: TNC

cooling: DC fan

7.1 Functional description

The BeneBoost car amplifier increases the power of Benefon Spica or Titan to max. 15 watts. It also includes a front end amplifier for the received signal. When attached to the phone holder, Benefon Spica or Titan takes control over the booster module, switching the power on and changing the output power to appropriate level.

7.1.1 Transmitting section and power control

The signal from Benefon Spica or Titan is fed via connector V5 to a duplex filter X1, which combines TX and RX chains at the phone end of the booster. When connected to the booster via the car kit, the phone transmits at a low power level (150mW). This signal is then amplified at a transistor Q2 and a power hybrid I1 before a duplex filter X2, which combines the TX and RX chains at the antenna end of the booster.

The signal from a directional coupler is rectified with a biased schottky diode D1 and filtered in a RC filter before a gain control consisting of dual OP-amp. I3 and transistors Q3 and Q9. Control lines TX1, TX0 and HITEMP are used to change the power level of the booster output. In the case that the output level is 15 W and the booster has been overheated, the HITEMP control drops output power 3 dB down. The transistor Q6 enables/disables the power output with a TXON control. 15 W Power is set with R31. A table below shows states of control lines and corresponding output power levels.

	Power OFF	PL1 150 mW	PL2 1.5 W	PL3 15W	PL3 7W
TX0	x	LOW	HIGH	LOW	LOW
TX1	x	LOW	LOW	HIGH	HIGH
HITEMP	x	HIGH	HIGH	LOW	HIGH
TXON	HIGH	LOW	LOW	LOW	LOW

7.1.2 Front end amplifier

Between duplex filters X1 and X2 is a one transistor stage Q7 which amplifies a RX signal to a proper level to the phone. It compensates losses generated in the duplex filters and RF cables. The amplifier is operational as long as the phone is fixed in the phone holder.

7.1.3 DC power and control logic

DC power from the vehicle's battery is fed to connector V2. The specified voltage range is 10.8 V to 15.6 V. A 3.3 V regulator I5 gets a power directly. After the phone is placed in the phone holder, a risen voltage level at I2C bus is detected by diode pair D5 and FET Q8 which activates the regulator. A booster detection control BODET rises up and an I2C remote I/O IC I6 will be ready to communicate with the phone.

7.1.4 Testpoint levels

Voltage levels at testpoints are measured in middle channel and using 13.6 V power supply voltage. Levels will vary because of component tolerances.

Testpoint	low power	mid. power	high power - 3 dB	high power	unit
TP1	3.5	3.5	3.5	3.5	V
TP2	9.6	9.6	9.6	9.6	V
TP3	13.6	13.5	13.5	13.4	V
TP4	13.6	13.5	13.5	13.4	V
V6	0.25	0.74	1.68	2.48	V
V7	129	142	167	190	mV
V8	0.49	0.51	0.53	0.56	V
V9	4.88	5.41	6.21	6.94	V
V10	0.7	0.7	0.7	0.7	V
V11	0.7	0.7	0.7	0.3	V
V12	0	0.7	0	0	V
V13	0	0	0.7	0.7	V
V14	0	0	0	0.7	V
V15	5.17	5.70	6.50	7.23	V
V16	13.6	13.5	13.5	13.4	V

7.1.5 Part lists OC1910

OC1910

CODE	PART	DESCRIPT.	VALUE	MANUF.	TYPE
CF0101	C1	SMD capasitor	100 pF 5% 50 V NP0	Philips	
CF0101	C10	SMD capasitor	100 pF 5% 50 V NP0	Philips	
CF0101	C11	SMD capasitor	100 pF 5% 50 V NP0	Philips	
CF0102	C12	SMD capasitor	1 nF 5 % NP0	Philips	
CF0101	C13	SMD capasitor	100 pF 5% 50 V NP0	Philips	
CF0101	C14	SMD capasitor	100 pF 5% 50 V NP0	Philips	
CF0101	C15	SMD capasitor	100 pF 5% 50 V NP0	Philips	
CF0102	C16	SMD capasitor	1 nF 5 % NP0	Philips	
CF0101	C17	SMD capasitor	100 pF 5% 50 V NP0	Philips	
CH0105	C18	SMD capasitor	1uF/-20/+80%/16V	TaiyoYuden	EMK212 F105Z00T
CF0101	C19	SMD capasitor	100 pF 5% 50 V NP0	Philips	
CF0101	C2	SMD capasitor	100 pF 5% 50 V NP0	Philips	
CF0101	C20	SMD capasitor	100 pF 5% 50 V NP0	Philips	
CF0222	C21	SMD capasitor	2.2 nF 5% 50 V NP0	Philips	
CF0331	C22	SMD capasitor	330 pF 5% 50 V NP0	Philips	
CH0105	C23	SMD capasitor	1uF/-20/+80%/16V	TaiyoYuden	EMK212 F105Z00T
CH0105	C24	SMD capasitor	1uF/-20/+80%/16V	TaiyoYuden	EMK212 F105Z00T
CF0689	C26	SMD capasitor	6.8 pF/0.25pF 50 V NP0	Philips	
CH0105	C27	SMD capasitor	1uF/-20/+80%/16V	TaiyoYuden	EMK212 F105Z00T
CF0470	C28	SMD capasitor	47 pF 5% 50 V NP0	Philips	
CF0101	C3	SMD capasitor	100 pF 5% 50 V NP0	Philips	
CE0476	C33	Al elko	47 uF/25 V 7x7mm	Philips	2222 097 56479
CF0103	C34	SMD capasitor	10 nF 10% 50 V X7R	Philips	
CF0103	C35	SMD capasitor	10 nF 10% 50 V X7R	Philips	
CU4106	C36	SMD tantal	10uF/25V 20%	AVX	TAJC106M025R
CU2475	C38	SMD tantal	4.7uF/16V 20% 3.5x2.8	AVX	TAJB475M016R
CU1105	C39	SMD tantal	1uF/16V	AVX	TAJR105M016R
CF0101	C4	SMD capasitor	100 pF 5% 50 V NP0	Philips	
CH0105	C40	SMD capasitor	1uF/-20/+80%/16V	TaiyoYuden	EMK212 F105Z00T
CF0101	C41	SMD capasitor	100 pF 5% 50 V NP0	Philips	
CH0105	C42	SMD capasitor	1uF/-20/+80%/16V	TaiyoYuden	EMK212 F105Z00T
CF0101	C43	SMD capasitor	100 pF 5% 50 V NP0	Philips	
CH0105	C44	SMD capasitor	1uF/-20/+80%/16V	TaiyoYuden	EMK212 F105Z00T
CF0101	C46	SMD capasitor	100 pF 5% 50 V NP0	Philips	
CF0101	C5	SMD capasitor	100 pF 5% 50 V NP0	Philips	
CH0105	C52	SMD capasitor	1uF/-20/+80%/16V	TaiyoYuden	EMK212 F105Z00T
CH0105	C53	SMD capasitor	1uF/-20/+80%/16V	TaiyoYuden	EMK212 F105Z00T
CF0102	C54	SMD capasitor	1 nF 5 % NP0	Philips	
CH0105	C55	SMD capasitor	1uF/-20/+80%/16V	TaiyoYuden	EMK212 F105Z00T
000000	C56	*** EI KOODATTU VARAS- TOON ***			
CF0101	C6	SMD capasitor	100 pF 5% 50 V NP0	Philips	
CF0399	C7	SMD capasitor	3.9pF 0.25 50V NP0	Philips	
CH0105	C8	SMD capasitor	1uF/-20/+80%/16V	TaiyoYuden	EMK212 F105Z00T
CF0102	C9	SMD capasitor	1 nF 5 % NP0	Philips	
DY0074	D1	Shottky diode		Philips	BAT 74
DZ0569	D2	SMD zener	5V6 5% 300mW	Philips	BZX84C5V6
DS0070	D3	SMD diode pair	70V/100mA common cathode	Philips	BAV 70
DZ0180	D4	SMD zener	18V 5% 300mW	Philips	BZX84C18
DS1070	D5	SMD diode pair	70V/100mA common cathode	Philips	BAV 70W
DS0070	D6	SMD diode pair	70V/100mA common cathode	Philips	BAV 70
DS0070	D7	SMD diode pair	70V/100mA common cathode	Philips	BAV 70
DY0014	D8	SMD diode	1,5A/40V	Shindengen	D1FS4A
DT1518	D9	SMD Transient filter	18 /1500W	SGS- Thomso	SM15T18A
IW7729	I1	RF-power amplifier	450-470MHz,12.5V 15W	Mitsubishi	M57729H

CODE	PART	DESCRIPT.	VALUE	MANUF.	TYPE
IR2952	I2	Regulator	100mA 5V adj. 0.5%	Micrel	MIC2951-02BM
IA0272	I3	2 x op.amp.	LinCMOS Low noise,power	Texas	TLC27M2ID
IX0623	I4	Temperature sensor		TelCom	TC623CEOA
IR2952	I5	Regulator	100mA 5V adj. 0.5%	Micrel	MIC2951-02BM
II8574	I6	8 bit I/O	I2C	Philips	PCF8574T
LC3822	L1	SMD inductor	8n2 +-2%	Panasonic	ELJRE8N2ZF2
LC2154	L2	SMD inductor	150 nH/+/-10%	TDK	MLF2012DR15KT
LF0396	L3	Inductor	39 uH	Philips	
LF0396	L4	Inductor	39 uH	Philips	
LC2154	L5	SMD inductor	150 nH/+/-10%	TDK	MLF2012DR15KT
LC2104	L6	SMD inductor	100 nH/+/-10%	TDK	MLF2012DR10KT
QS0848	Q1	SMD transistor	NPN 0.1A/30V hFE 110-800	Philips	BC848BW, 115
QS0848	Q10	SMD transistor	NPN 0.1A/30V hFE 110-800	Philips	BC848BW, 115
QS0031	Q11	SMD transistor	PNP 1A/25V	Sanyo	2SB1119S-TD
QS0848	Q12	SMD transistor	NPN 0.1A/30V hFE 110-800	Philips	BC848BW, 115
QS0848	Q13	SMD transistor	NPN 0.1A/30V hFE 110-800	Philips	BC848BW, 115
QS0848	Q14	SMD transistor	NPN 0.1A/30V hFE 110-800	Philips	BC848BW, 115
QS0858	Q15	SMD transistor	PNP 0.1A/30V hFE 125-800	Philips	BC858BW
QS0848	Q16	SMD transistor	NPN 0.1A/30V hFE 110-800	Philips	BC848BW, 115
QA0035	Q2	SMD RF-transistor	NPN Wideband 1GHz	Philips	BFG-35
QS0848	Q3	SMD transistor	NPN 0.1A/30V hFE 110-800	Philips	BC848BW, 115
QS0848	Q4	SMD transistor	NPN 0.1A/30V hFE 110-800	Philips	BC848BW, 115
QS0848	Q5	SMD transistor	NPN 0.1A/30V hFE 110-800	Philips	BC848BW, 115
QS0848	Q6	SMD transistor	NPN 0.1A/30V hFE 110-800	Philips	BC848BW, 115
QA4869	Q7	SMD RF-transistor	NPN G=15dB NF=1.2dB/1GHz	Sanyo	2SC4869-5-TG
QF7002	Q8	SMD n-channel FET	60V 0.115A Rds7.5	Siliconix	2N7002-T1
QP0132	Q9	SMD power transistor	PNP -3A/45V	Philips	BDP32
RF0473	R1	SMD resistor	47 k 5% 0.125 W	Kamaya	
RF0271	R10	SMD resistor	270 R 5% 0.125 W	Kamaya	
RF0271	R11	SMD resistor	270 R 5% 0.125 W	Kamaya	
RF0820	R12	SMD resistor	82 R 5% 0.125 W	Kamaya	
RF0473	R13	SMD resistor	47 k 5% 0.125 W	Kamaya	
RF0153	R14	SMD resistor	15 k 5% 0.125 W	Kamaya	
RF0102	R15	SMD resistor	1 k 5% 0.125 W	Kamaya	
RF0103	R16	SMD resistor	10 k 5% 0.125 W	Kamaya	
RF0222	R17	SMD resistor	2.2 k 5% 0.125 W	Kamaya	
RC0100	R18	SMD resistor	10 R 5% 0.125 W	Kamaya	
RC0100	R19	SMD resistor	10 R 5% 0.125 W	Kamaya	
RF0821	R2	SMD resistor	820 R 5% 0.125 W	Kamaya	
RC0100	R20	SMD resistor	10 R 5% 0.125 W	Kamaya	
RF0221	R21	SMD resistor	220 R 5% 0.125 W	Kamaya	
RF0222	R22	SMD resistor	2.2 k 5% 0.125 W	Kamaya	
RF0391	R23	SMD resistor	390 R 5% 0.125 W	Kamaya	
RF0331	R24	SMD resistor	330 R 5% 0.125 W	Kamaya	
RF0223	R25	SMD resistor	22 k 5% 0.125 W	Kamaya	
RF0223	R26	SMD resistor	22 k 5% 0.125 W	Kamaya	
RF0223	R27	SMD resistor	22 k 5% 0.125 W	Kamaya	
RF0223	R28	SMD resistor	22 k 5% 0.125 W	Kamaya	
RF0103	R29	SMD resistor	10 k 5% 0.125 W	Kamaya	
RF0151	R3	SMD resistor	150 R 5% 0.125 W	Kamaya	
RF0103	R30	SMD resistor	10 k 5% 0.125 W	Kamaya	
RI1103	R31	SMD trimmer resistor	10k 20%	Teikoku	TMC 4 K
RF0184	R32	SMD resistor	180 k 5% 0.125 W	Kamaya	
RF0823	R33	SMD resistor	82 k 5% 0.125 W	Kamaya	
RF0474	R34	SMD resistor	470 k 5% 0.125 W	Kamaya	
RF0474	R35	SMD resistor	470 k 5% 0.125 W	Kamaya	
RF0104	R36	SMD resistor	100 k 5% 0.125 W	Kamaya	
RF0104	R37	SMD resistor	100 k 5% 0.125 W	Kamaya	
RF0103	R38	SMD resistor	10 k 5% 0.125 W	Kamaya	
RF0474	R39	SMD resistor	470 k 5% 0.125 W	Kamaya	

CODE	PART	DESCRIPT.	VALUE	MANUF.	TYPE
RF0472	R4	SMD resistor	4.7 k 5% 0.125 W	Kamaya	
RF0270	R40	SMD resistor	27 R 5% 0.125 W	Kamaya	
RF0104	R41	SMD resistor	100 k 5% 0.125 W	Kamaya	
RF0331	R42	SMD resistor	330 R 5% 0.125 W	Kamaya	
RF0103	R43	SMD resistor	10 k 5% 0.125 W	Kamaya	
RF0103	R44	SMD resistor	10 k 5% 0.125 W	Kamaya	
RF0562	R45	SMD resistor	5.6 k 5% 0.125 W	Kamaya	
RF0152	R46	SMD resistor	1.5 k 5% 0.125 W	Kamaya	
RF0103	R47	SMD resistor	10 k 5% 0.125 W	Kamaya	
RF0103	R48	SMD resistor	10 k 5% 0.125 W	Kamaya	
RF0103	R49	SMD resistor	10 k 5% 0.125 W	Kamaya	
RF0103	R5	SMD resistor	10 k 5% 0.125 W	Kamaya	
RF0101	R50	SMD resistor	100 R 5% 0.125 W	Kamaya	
RF0223	R51	SMD resistor	22 k 5% 0.125 W	Kamaya	
RF0103	R52	SMD resistor	10 k 5% 0.125 W	Kamaya	
RF0470	R53	SMD resistor	47 R 5% 0.125 W	Kamaya	
RF0470	R54	SMD resistor	47 R 5% 0.125 W	Kamaya	
RF0470	R55	SMD resistor	47 R 5% 0.125 W	Kamaya	
RF0470	R56	SMD resistor	47 R 5% 0.125 W	Kamaya	
RF0104	R57	SMD resistor	100 k 5% 0.125 W	Kamaya	
RF0103	R58	SMD resistor	10 k 5% 0.125 W	Kamaya	
RF0103	R59	SMD resistor	10 k 5% 0.125 W	Kamaya	
RF0391	R6	SMD resistor	390 R 5% 0.125 W	Kamaya	
RF0103	R60	SMD resistor	10 k 5% 0.125 W	Kamaya	
RF0102	R61	SMD resistor	1 k 5% 0.125 W	Kamaya	
RF1124	R62	SMD resistor	120 k 1% 0.125 W	KOA	
RF1154	R63	SMD resistor	150 k 1% 0.125 W	KOA	
RF0000	R64	SMD resistor	0 R	Kamaya	
000000	R65	*** EI KOODATTU VARAS- TOON ***			
RF0103	R66	SMD resistor	10 k 5% 0.125 W	Kamaya	
RF0104	R67	SMD resistor	100 k 5% 0.125 W	Kamaya	
RF0102	R68	SMD resistor	1 k 5% 0.125 W	Kamaya	
RF0154	R69	SMD resistor	150 k 5% 0.125 W	Kamaya	
RF0391	R7	SMD resistor	390 R 5% 0.125 W	Kamaya	
RF0105	R70	SMD resistor	1 M 5% 0.125 W	Kamaya	
RF0103	R73	SMD resistor	10 k 5% 0.125 W	Kamaya	
RF0100	R8	SMD resistor	10 R 5% 0.125 W	Kamaya	
RF0180	R9	SMD resistor	18 R 5% 0.125 W	Kamaya	
AR0005	S2	Relay	12V/10A 19x15,4x15,5mm	Good Sky E	RW-SH-112D
VW0106	V2	Connector	male 6-pin	Molex	5569-06-A1
VN7876	V3	USB-connector	4 pin RF-shielded	AMP	787616-1
VR1121	V4	RF-connector	TNC for PCB board	IMS connec	1121.02.2620.00
VR1121	V5	RF-connector	TNC for PCB board	IMS connec	1121.02.2620.00
OD0062	X1	Duplexer PL/BG	452.000-457.475MHz/3W	LK-Product	X4-B8/NP1
OD0063	X2	Duplexer PL/BG	452.000-457.475MHz/25W	LK-Product	Q4-A9/NP1
LF0062	X4	SMD EMI filter	10nF/2A	Panasonic	ELKE103FA

Last
update
01.03.99

The Top Side Layout PC1900A3

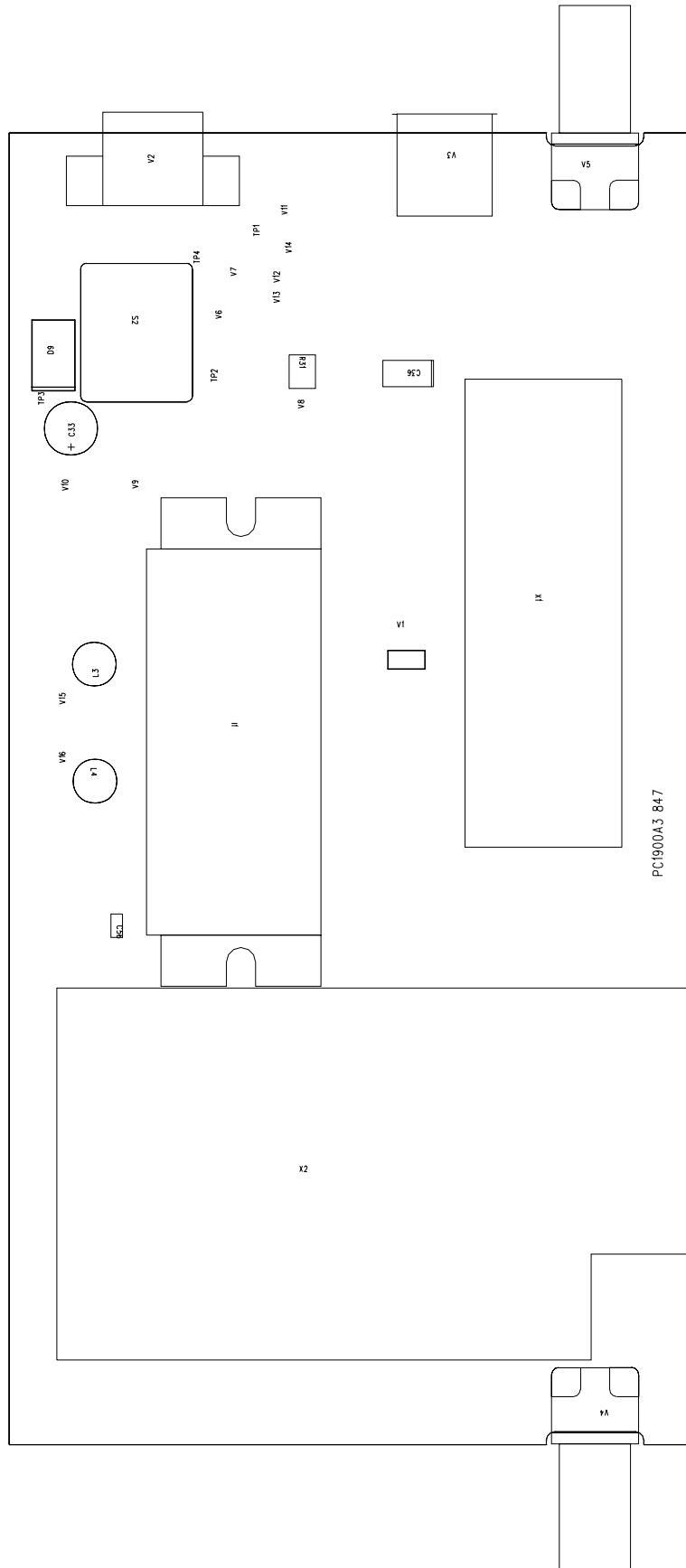

The Bottom Side Layout PC1900A3

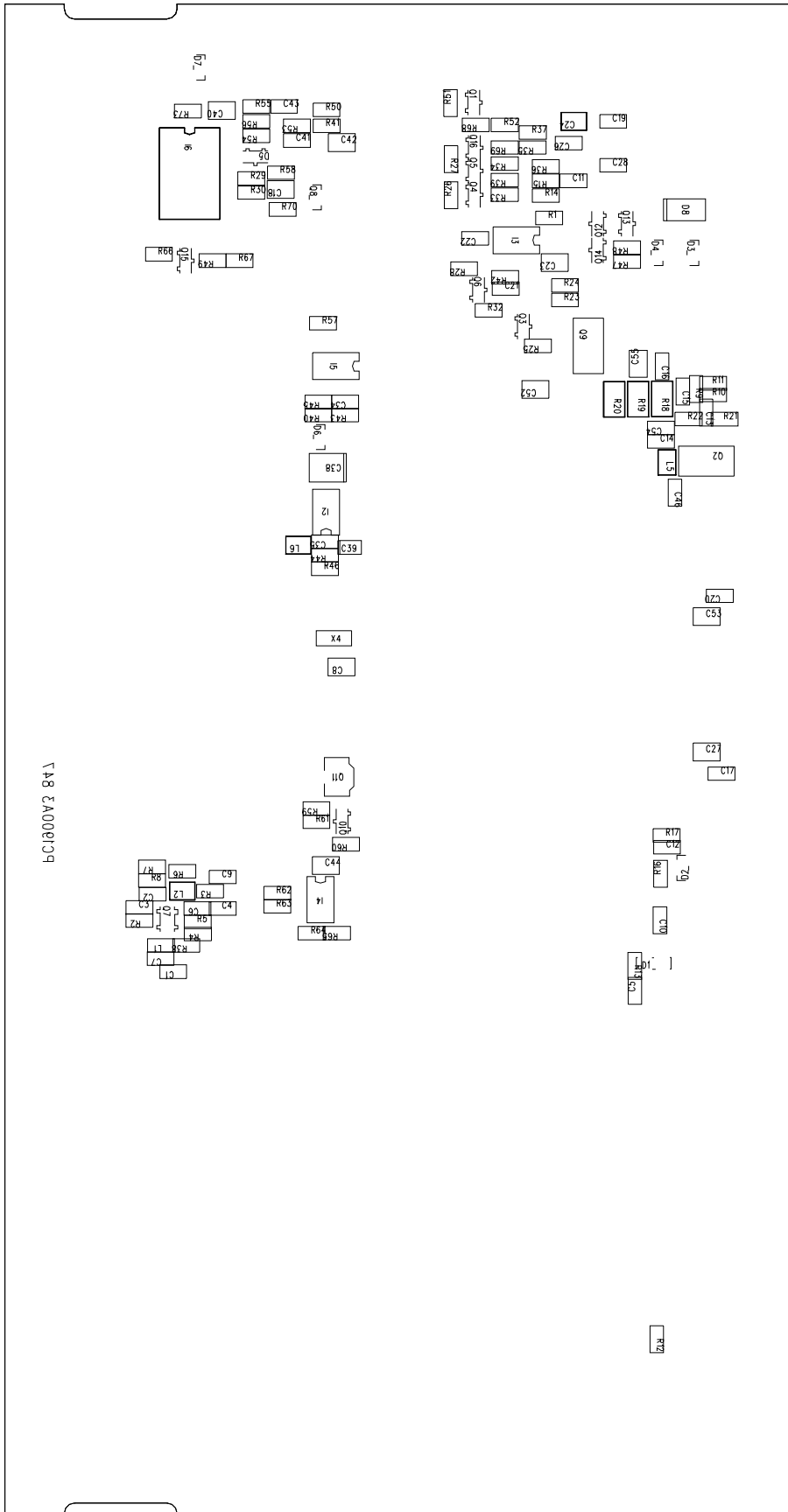

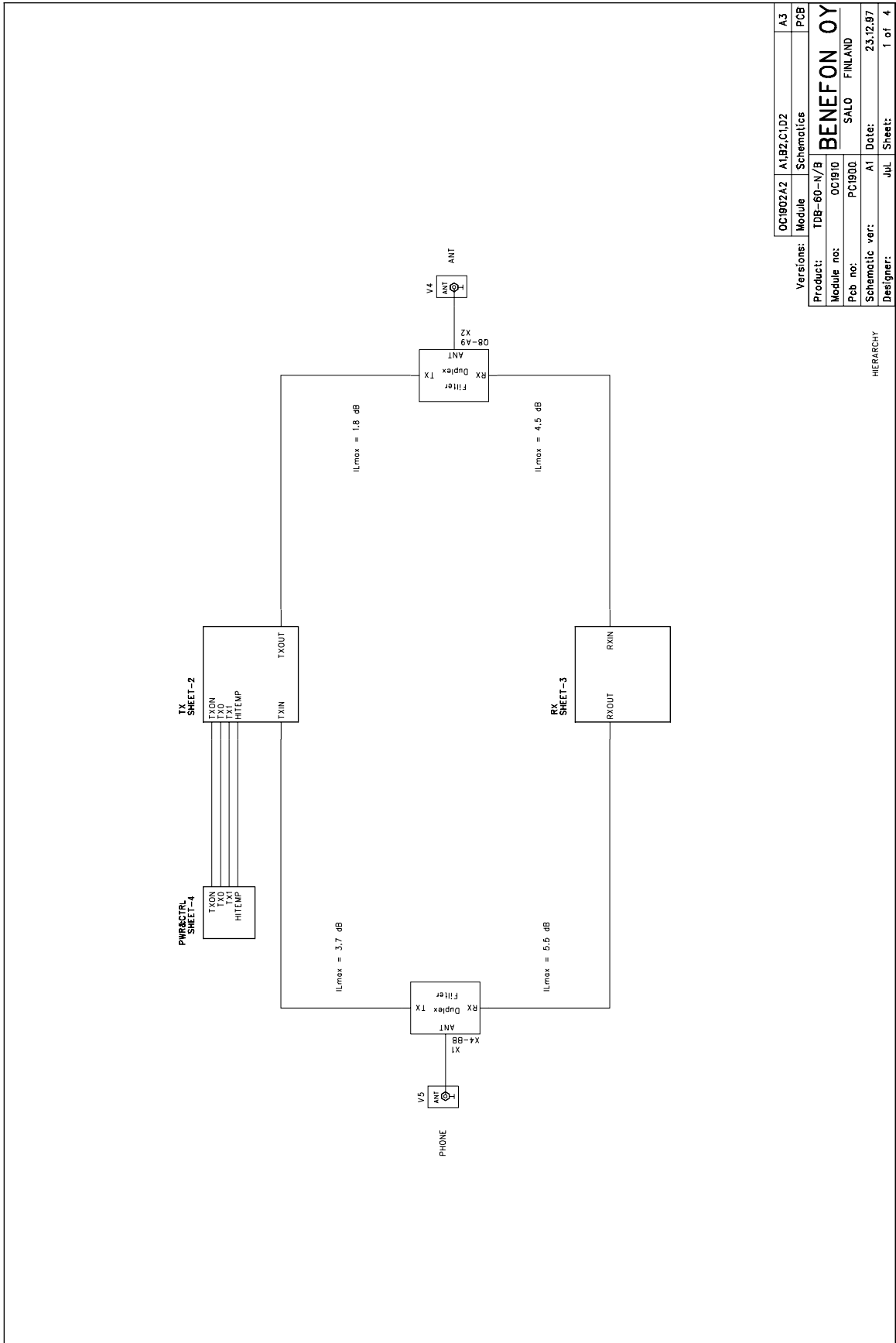

OC1902A2	A1B2,C1,D2	A3
Module	Schematics	PCB
Product:	TDB-60-N/B	BENEFON OY
Module no:	OC1910	SALO FINLAND
Pub no:	PC1900	
Schematic ver:	A1	Date: 23.12.97
Designer:	JUL	Sheet: 1 of 4

HIERARCHY

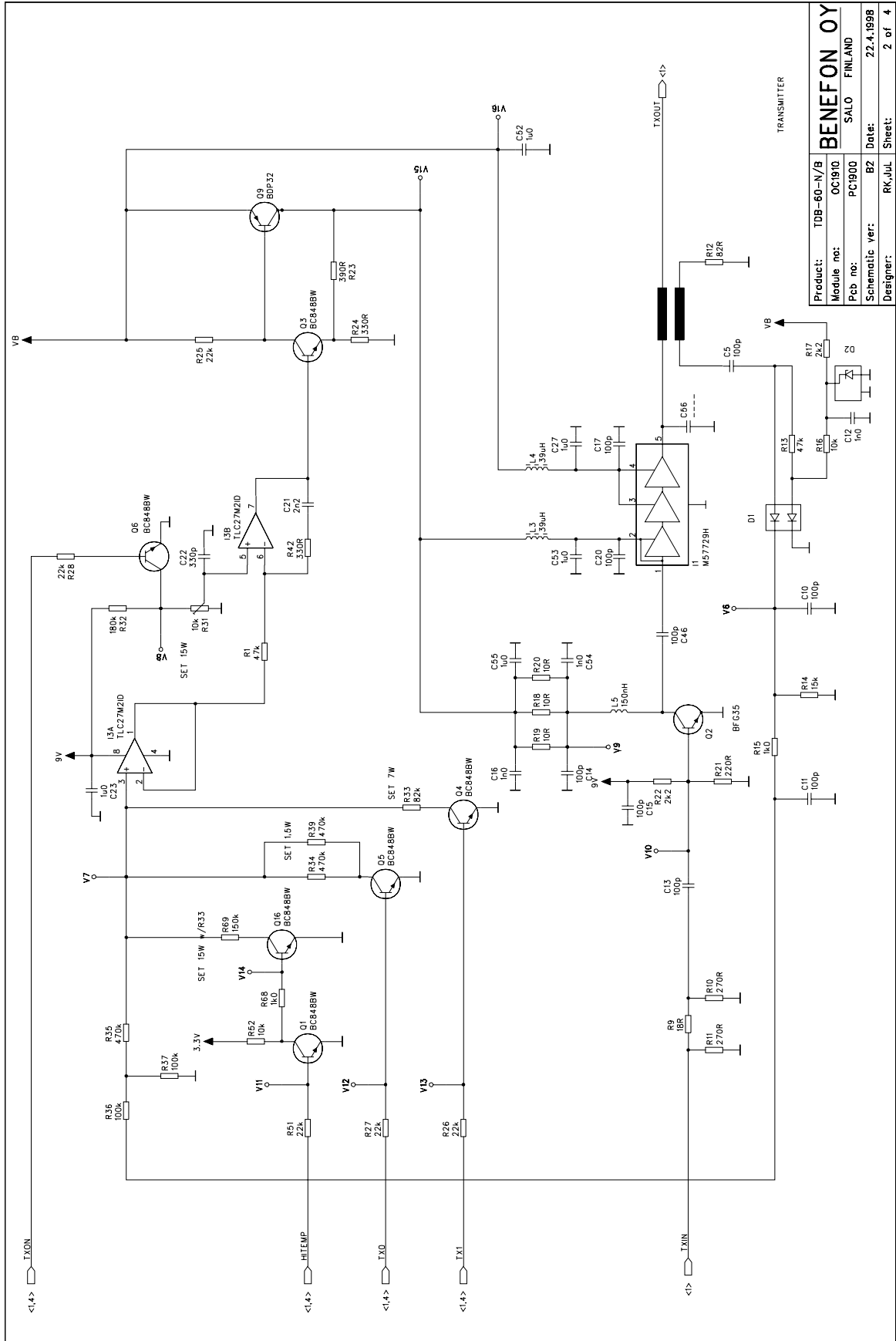

Product:	TDB-60-N/B	BENEFON OY
Module no:	OC1910	SALO FINLAND
Part no:	PC1900	
Schematic ver:	B2	Date: 22.4.1999
Designer:	RK.JUL	Sheet: 2 of 4

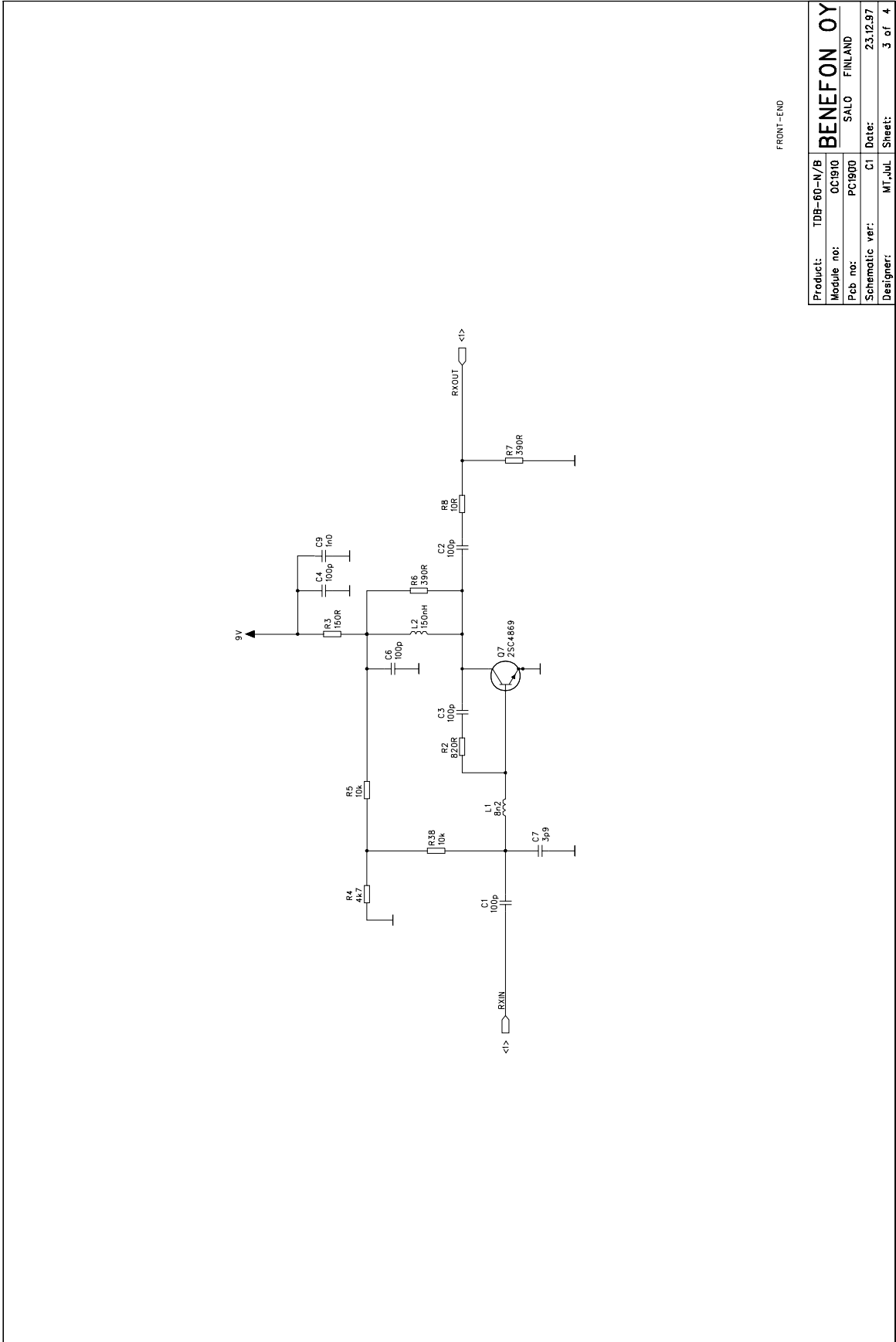

FRONT-END

Product:	TDB-60-N/B	BENEFON OY	
Module no:	OC1910	SALO	FINLAND
Pcb no:	PC1900	Date:	23.12.97
Schematic ver:	C1	Designer:	MT,Jul
Sheet:	3 of 4		

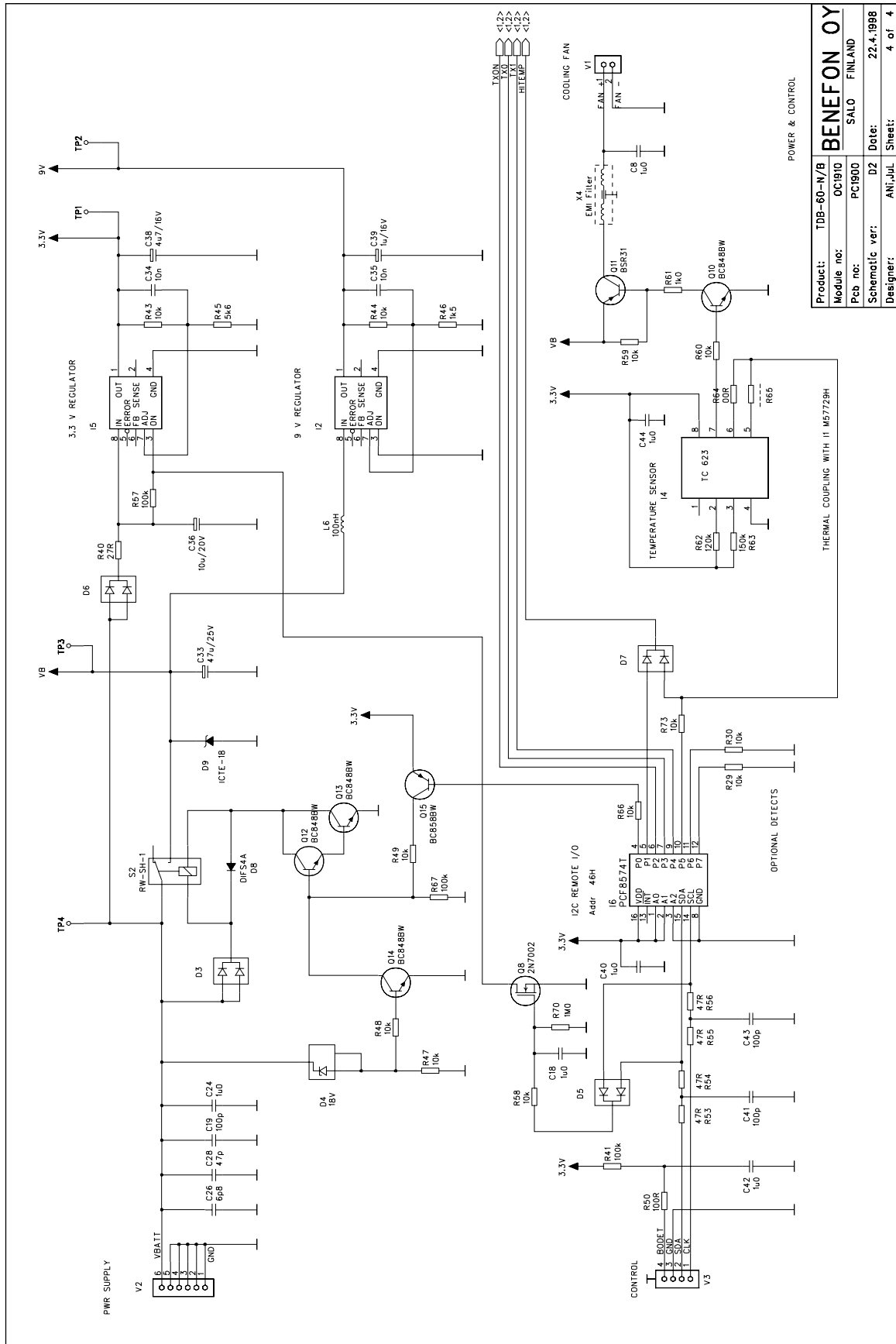

Product:	TDB-60-N/B	BENEFON OY
Module no:	OC1910	SALO FINLAND
Pcb no:	PC1900	
Schematic ver:	D2	Date: 22.4.1998
Designer:	ANI,jul	Sheet: 4 of 4

8.0 OTHER ACCESSORIES

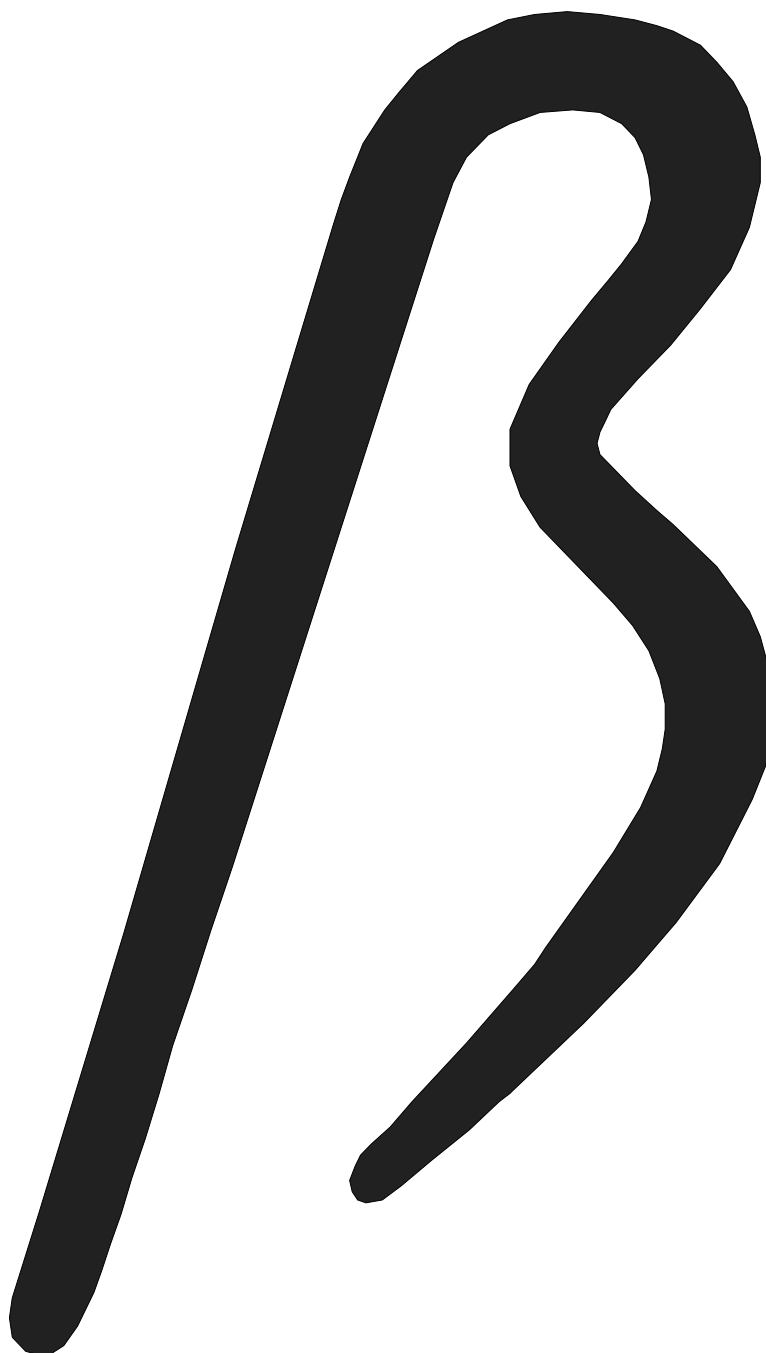

OTHER ACCESSORIES

8.1 PORTABLE HANDS FREE KIT EHD-60

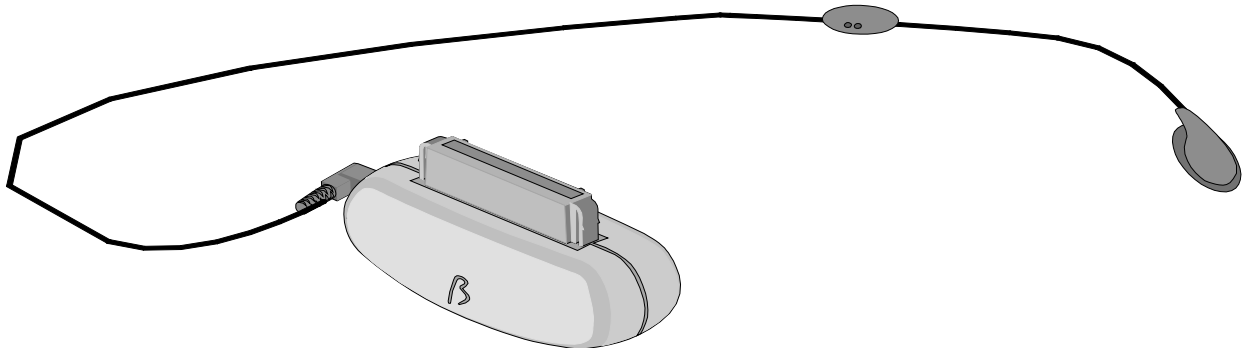

The Benefon portable hands free kit is designed to make the use of a mobile phone easier in various working situations. When you plug the portable hands free kit into your phone you can make and answer phone calls and use your hands at the same time.

The portable hands free kit consists of an earpiece/microphone part and an adapter (EHD-60).

8.1.1 SPECIFICATION FOR HEADSET ADAPTER OO0313

8.1.1.1 Including attached functions

- power supply filtering
- voltage regulator
- handsfree amplifiers
- cellular phone connector
- earphone connector

8.1.2 Connector descriptions

8.1.2.1 Earphone connector V101:

1	GND	ground
2	MIC	audiosignal from microphone
3	ERP	audiosignal to earphone
4	NC	

8.1.2.2 Cellular phone connector V100

1	NC	
2	NC	
3	VBATT	battery voltage
4	NC	
5	EXTMIC	microphone signal
6	GND	ground
7	GND	ground
8	EXTERP	earphone signal
9	CADET	not used
10	NC	
11	NC	
12	NC	
13	NC	
14	NC	
15	EXTIO	external I/O
16	NC	

8.1.3 Operation

Operating voltage is fed to pin VBATT (V100.3). It is regulated to 3.3 V (VB) with I101.

Reference voltage $VB/2$ is produced with voltage divider R120 and R 121.

Bias voltage to microphone is fed through R100, R101 and R102.

Audiosignal from microphone is amplified and filtered by amplifiers I100A and I100B. Audiosignal to earphone is amplified by amplifiers I100C and I100D.

Detection of headset adapter is done by pulling pin V100/15 (EXTIO) to ground with resistor R151.

8.1.4 Parts list OO0313

CODE	PART	DESCRIPT.	VALUE	MANUF.	TYPE
CU3106	C100	SMD tantal	10uF / 6V +-20%	AVX	TAJA106M006R
CU3106	C101	SMD tantal	10uF / 6V +-20%	AVX	TAJA106M006R
CF0473	C103	SMD capacitor	47 nF 10% 50 V X7R	Philips	
CF0270	C104	SMD capacitor	27pF 5% 50V NPO	Philips	
CF0270	C105	SMD capacitor	27pF 5% 50V NPO	Philips	
CF0330	C106	SMD capacitor	33 pF 5% 50 V NPO	Philips	
CF0223	C107	SMD capacitor	22 nF 10% 50 V X7R	Philips	
CF0101	C108	SMD capacitor	100 pF 5% 50 V NPO	Philips	
CF0473	C110	SMD capacitor	47 nF 10% 50 V X7R	Philips	
CF0270	C111	SMD capacitor	27pF 5% 50V NPO	Philips	
CF0270	C112	SMD capacitor	27pF 5% 50V NPO	Philips	
CF0330	C113	SMD capacitor	33 pF 5% 50 V NPO	Philips	
CF0473	C114	SMD capacitor	47 nF 10% 50 V X7R	Philips	
CU3106	C120	SMD tantal	10uF / 6V +-20%	AVX	TAJA106M006R
CF0101	C121	SMD capacitor	100 pF 5% 50 V NPO	Philips	
CU3106	C122	SMD tantal	10uF / 6V +-20%	AVX	TAJA106M006R
CU3475	C123	SMD tantal	4.7uF/10V 20%	AVX	TAJA475M010R
CF0101	C124	SMD capacitor	100 pF 5% 50 V NPO	Philips	
CU3106	C130	SMD tantal	10uF / 6V +-20%	AVX	TAJA106M006R
CF0101	C131	SMD capacitor	100 pF 5% 50 V NPO	Philips	
CF0270	C132	SMD capacitor	27pF 5% 50V NPO	Philips	
CF0270	C133	SMD capacitor	27pF 5% 50V NPO	Philips	
CF0473	C134	SMD capacitor	47 nF 10% 50 V X7R	Philips	
CF0270	C140	SMD capacitor	27pF 5% 50V NPO	Philips	
CF0270	C141	SMD capacitor	27pF 5% 50V NPO	Philips	
CF0270	C142	SMD capacitor	27pF 5% 50V NPO	Philips	
CF0473	C143	SMD capacitor	47 nF 10% 50 V X7R	Philips	
CF0101	C150	SMD capacitor	100 pF 5% 50 V NPO	Philips	
CF0270	C151	SMD capacitor	27pF 5% 50V NPO	Philips	
CF0270	C152	SMD capacitor	27pF 5% 50V NPO	Philips	
CF0270	C160	SMD capacitor	27pF 5% 50V NPO	Philips	
CF0270	C161	SMD capacitor	27pF 5% 50V NPO	Philips	
IA6484	I100	Quad op.amp.	CMOS Rail-to-rail I/O	NationalSe	LMC6484IM
IR2986	I101	Regulator	3.3V 200mA	NationalSe	LP2986A1MMX-3.3
LF0102	L124	SMD EMIFIL		Murata	BLM21A102FPT
LF0102	L126	SMD EMIFIL		Murata	BLM21A102FPT
LF0102	L160	SMD EMIFIL		Murata	BLM21A102FPT
LF0102	L161	SMD EMIFIL		Murata	BLM21A102FPT
LF0102	L162	SMD EMIFIL		Murata	BLM21A102FPT
RF0471	R100	SMD resistor	470 R 5% 0.125 W	Kamaya	
RF0471	R101	SMD resistor	470 R 5% 0.125 W	Kamaya	
RF0222	R102	SMD resistor	2.2 k 5% 0.125 W	Kamaya	
RF0103	R103	SMD resistor	10 k 5% 0.125 W	Kamaya	
RF0822	R104	SMD resistor	8.2 k 5% 0.125 W	Kamaya	
RF0683	R105	SMD resistor	68 k 5% 0.125 W	Kamaya	
RF0103	R110	SMD resistor	10 k 5% 0.125 W	Kamaya	
RF0103	R111	SMD resistor	10 k 5% 0.125 W	Kamaya	
RF0104	R112	SMD resistor	100 k 5% 0.125 W	Kamaya	
RF0222	R113	SMD resistor	2.2 k 5% 0.125 W	Kamaya	
RF0222	R120	SMD resistor	2.2 k 5% 0.125 W	Kamaya	
RF0222	R121	SMD resistor	2.2 k 5% 0.125 W	Kamaya	
RF0100	R123	SMD resistor	10 R 5% 0.125 W	Kamaya	
RD0102	R125	SMD resistor	1 k 5% 0.125 W	Kamaya	
RD0102	R127	SMD resistor	1 k 5% 0.125 W	Kamaya	
RF0101	R130	SMD resistor	100 R 5% 0.125 W	Kamaya	
RF0103	R131	SMD resistor	10 k 5% 0.125 W	Kamaya	
RF0472	R132	SMD resistor	4.7 k 5% 0.125 W	Kamaya	

CODE	PART	DESCRIPT.	VALUE	MANUF.	TYPE
RF0103	R133	SMD resistor	10 k 5% 0.125 W	Kamaya	
RF0103	R140	SMD resistor	10 k 5% 0.125 W	Kamaya	
RF0472	R141	SMD resistor	4.7 k 5% 0.125 W	Kamaya	
RF0103	R142	SMD resistor	10 k 5% 0.125 W	Kamaya	
RF0103	R151	SMD resistor	10 k 5% 0.125 W	Kamaya	
VN0342	V100	SMD system connector	16 pin	AMP	338271-1
VN0009	V101	Stereo jack	2,5mm miniature	Hosiden	HSJ1603-010020

Last
update
18.03.98

The Top Side Layout PO0313

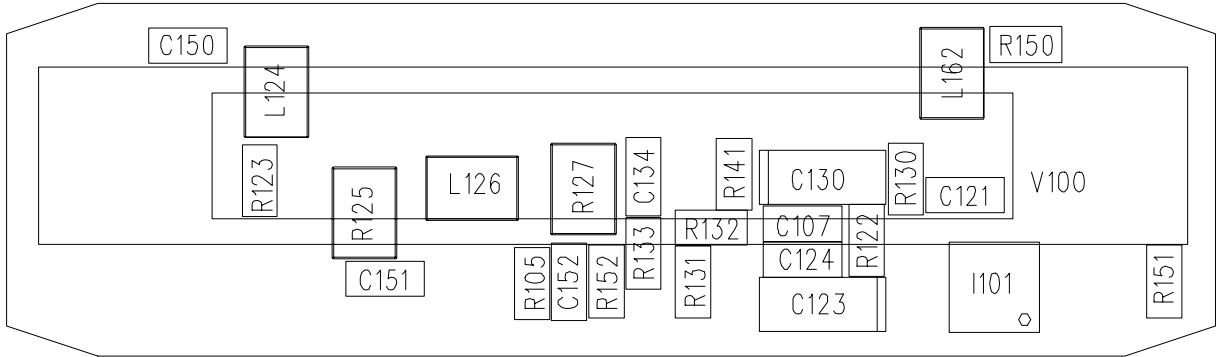

P00313A1 803

The Bottom Side Layout PO0313

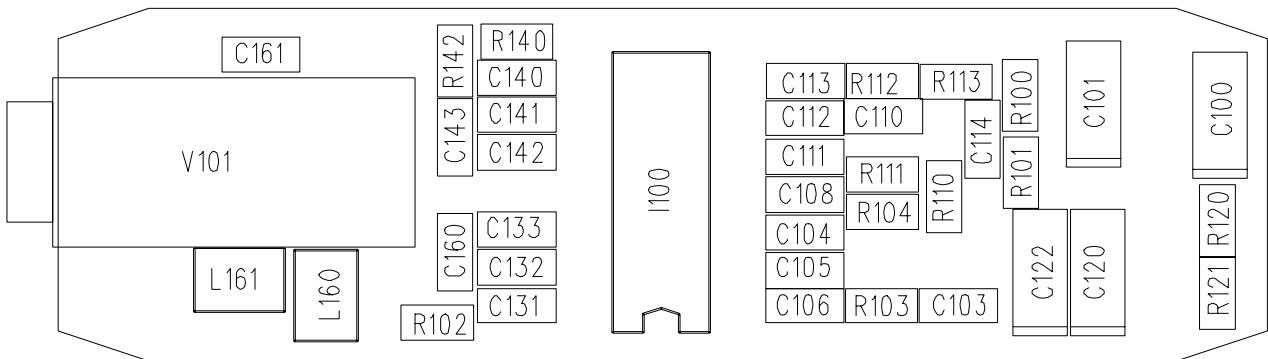

P00313A1 803

