



MTH800

**TETRA Handportable
Terminal**

380-430 MHz (PT911FR)

440-470 MHz (PT511FR 1)

Basic Service Manual

Part Number: 6866539D22-D



COPYRIGHT

Copyrights

© 2008 Motorola Inc. All rights reserved.

No part of this manual may be reproduced, transmitted, stored in a retrieval system, or translated into any language or computer language, in any form or by any means, without the prior written permission of Motorola Inc.

Computer Software Copyrights

The Motorola products described in this manual may include copyrighted Motorola computer programs stored in semiconductor memories or other media. Laws in the United States and other countries preserve for Motorola certain exclusive rights for copyrighted computer programs including, but not limited to, the exclusive right to copy or reproduce in any form the copyrighted computer program. Accordingly, any copyrighted Motorola computer programs contained in the Motorola products described in this manual may not be copied, reproduced, modified, reverse-engineered, or distributed in any manner without the express written permission of Motorola. Furthermore, the purchase of Motorola products shall not be deemed to grant either directly or by implication, estoppel, or otherwise, any license under the copyrights, patents or patent applications of Motorola, except for the normal non-exclusive royalty-free license to use that arises by operation of law in the sale of a product.

Trademarks

MOTOROLA and the Stylized M Logo are registered in the U.S. Patent and Trademark Office. All other product or service names are the property of their respective owners.

© Motorola, Inc. 2008

DOCUMENT HISTORY

The following major changes have been implemented in this manual since the previous edition:

Edition	Description	Date
6866539D22-A	Initial edition with enhanced frequency range from 440-470MHz (based upon the predecessor service manual for 380-430 & 450-470MHz).	Aug. 2006
6866539D22-B	UCM-M Module (Upgrade kit GMLN4561) has been added to several chapters.	Dec. 2006
6866539D22-C	Updated GPS description (pg. 3-3) and service tanapa (pg. A-6).	Oct. 2007
6866539D22-D	Chapter 6 - Updated components list (pp. 6-24 to 6-25). - Updated replacement parts list (pg. 6-29).	Apr. 2008

Notes

SAFETY

Product Safety and RF Exposure for Portable Two-Way Radios

THIS CHAPTER IS AN EXTRACT OF THE MULTI LINGUAL PORTABLE SAFETY BOOKLET PUBLICATION No. 6864117B25. FOR THE LATEST SAFETY INFORMATION REFER TO THE SEPARATE SAFETY BOOKLET DELIVERED WITH YOUR RADIO.



Caution

BEFORE USING THIS RADIO, READ THIS BOOKLET WHICH CONTAINS IMPORTANT OPERATING INSTRUCTIONS FOR SAFE USAGE AND RF ENERGY AWARENESS AND CONTROL INFORMATION AND OPERATIONAL INSTRUCTIONS FOR COMPLIANCE WITH RF ENERGY EXPOSURE LIMITS IN APPLICABLE NATIONAL AND INTERNATIONAL STANDARDS. ALSO READ THE OPERATIONAL INSTRUCTIONS FOR SAFE USAGE. FOR RADIOS THAT HAVE BEEN APPROVED AS INTRINSICALLY SAFE, READ THE INSTRUCTIONS AND INFORMATION ON INTRINSIC SAFETY ON PAGE VII.

RF Energy Exposure Awareness and Control Information and Operational Instructions for Occupational Use

NOTICE: This radio is intended for use in occupational/controlled conditions where users have full knowledge of their exposure and can exercise control over their exposure to meet the occupational limits in FCC/ICNIRP and International standards. This radio device is NOT authorized for general population consumer use.

This two-way radio uses electromagnetic energy in the radio frequency (RF) spectrum to provide communications between two or more users over a distance. It uses radio frequency (RF) energy or radio waves to send and receive calls. RF energy is one form of electromagnetic energy. Other forms include, but are not limited to, sunlight and x-rays. RF energy, however, should not be confused with these other forms of electromagnetic energy, which when used improperly, can cause biological damage. Very high levels of x-rays, for example, can damage tissues and genetic material.

Experts in science, engineering, medicine, health, and industry work with organizations to develop standards for safe exposure to RF energy. These standards provide recommended levels of RF exposure for both workers and the general public. These recommended RF exposure levels include substantial margins of protection.

All Motorola two-way radios are designed, manufactured, and tested to ensure they meet government-established RF exposure levels. In addition, manufacturers also recommend specific operating instructions to users of two-way radios. These instructions are important because they inform users about RF energy exposure and provide simple procedures on how to control it.

Please refer to the following websites for more information on what RF energy exposure is and how to control your exposure to assure compliance with established RF exposure limits:

<http://www.fcc.gov/oet/rfsafety/rf-faqs.html>

<http://www.osha.gov/SLTC/radiofrequencyradiation/index.html>

Federal Communication Commission (FCC) Regulations (US markets only)

The FCC rules require manufacturers to comply with the FCC RF energy exposure limits for portable two-way radios before they can be marketed in the U.S. When two-way radios are used as a consequence of employment, the FCC requires users to be fully aware of and able to control their exposure to meet occupational requirements. Exposure awareness can be facilitated by the use of a product label directing users to specific user awareness information. Your Motorola two-way radio has a RF Exposure Product Label. Do not remove this RF Exposure Label from the device. Also, your Motorola user manual, or separate safety booklet includes information and operating instructions required to control your RF exposure and to satisfy compliance requirements.

Compliance with RF Exposure Standards

Your Motorola two-way radio is designed and tested to comply with a number of national and International standards and guidelines (listed below) for human exposure to radio frequency electromagnetic energy. **This radio complies with the IEEE (FCC) and ICNIRP exposure limits for occupational/controlled RF exposure environments at operating duty factors of up to 50% talk-50% listen and is authorized by the IEEE/ICNIRP for occupational use only.**

In terms of measuring RF energy for compliance with these exposure guidelines, **your radio generates measurable RF energy only while it is transmitting (during talking), not when it is receiving (listening) or in standby mode.**

NOTE: The approved batteries, supplied with the portable radio, are rated for a 5-5-90 duty cycle (5% talk–5% listen–90% standby), even though this radio complies with IEEE/ICNIRP occupational exposure limits at usage factors of up to 50% talk.

Your Motorola two-way radio complies with the following RF energy exposure standards and guidelines:

- United States Federal Communications Commission, Code of Federal Regulations; 47 CFR part 2 sub-part J
- American National Standards Institute (ANSI) / Institute of Electrical and Electronic Engineers (IEEE) C95. 1-1992
- Institute of Electrical and Electronic Engineers (IEEE) C95.1-1999 Edition
- International Commission on Non-Ionizing Radiation Protection (ICNIRP) 1998
- Ministry of Health (Canada) Safety Code 6. Limits of Human Exposure to Radiofrequency Electromagnetic Fields in the Frequency Range from 3 kHz to 300 GHz, 1999
- Australian Communications Authority Radiocommunications (Electromagnetic Radiation - Human Exposure) Standard, 2003
- ANATEL ANNEX to Resolution No. 303 of July 2, 2002 "Regulation of limitation of exposure to electrical, magnetic and electromagnetic fields in the radio frequency range between 9 KHz and 300 GHz" and "Attachment to resolution # 303 from July 2, 2002"

RF Exposure Compliance and Control Guidelines and Operating Instructions

To control your exposure and ensure compliance with the occupational/controlled environment exposure limits, always adhere to the following procedures:

Guidelines:

- User awareness instructions should accompany device when transferred to other users.
- Do not use this device if the operational requirements described herein are not met.

Operating Instructions:

- Transmit no more than the rated duty factor of 50% of the time. To transmit (talk), push the Push-To-Talk (PTT) button. To receive calls, release the PTT button. Transmitting 50% of the time, or less, is important because this radio generates measurable RF energy exposure only when transmitting (in terms of measuring for standards compliance).
- When worn on the body, always place the radio in a Motorola-approved clip, holder, holster, case, or body harness for this product. Using approved body-worn accessories is important because the use of non-Motorola-approved accessories may result in exposure levels, which exceed the IEEE/ICNIRP occupational/controlled environment RF exposure limits.
- If you are not using a body-worn accessory and are not using the radio in the intended use position, along side the head in the phone mode (TETRA only), in front of the face in the hand held mode, then ensure the antenna and the radio are kept 2.5 cm (one inch) from the body when transmitting. Keeping the radio at a proper distance is important because RF exposures decrease with increasing distance from the antenna.

Hand-held Mode - Operating Instructions:

- Hold the radio in a vertical position in front of the face with the microphone (and other parts of the radio including the antenna) at least 2.5 cm (one inch) away from the nose or lips. Antenna should be kept away from the eye. Keeping the radio at a proper distance is important since RF exposures decrease with increasing distance from the antenna.



Phone Mode (TETRA only) - Operating Instructions:

- When placing or receiving a phone call, hold your radio product as you would a wireless telephone. Speak directly into the microphone.

Approved Accessories

- Use only Motorola-approved supplied or replacement antennas, batteries, and accessories. Use of non-Motorola - approved antennas, batteries and accessories may exceed IEEE/ICNIRP RF exposure guidelines. For a list of Motorola-approved antennas, batteries, and other accessories please see your dealer or local Motorola contact. Your nearest dealer can be found at the following web site:

<http://www.motorola.com/businessandgovernment/wemea/en-gb/public/functions/dealerlocator/dealerlocator.aspx>

Additional Information

For additional information on exposure requirements or other training information, visit

<http://www.motorola.com/rfhealth>.

Electromagnetic Interference/Compatibility

NOTE: Nearly every electronic device is susceptible to electromagnetic interference (EMI) if inadequately shielded, designed, or otherwise configured for electromagnetic compatibility.

Facilities

To avoid electromagnetic interference and/or compatibility conflicts, turn off your radio in any facility where posted notices instruct you to do so. Hospitals or health care facilities may be using equipment that is sensitive to external RF energy.

Aircraft

When instructed to do so, turn off your radio when on board an aircraft. Any use of a radio must be in accordance with applicable regulations per airline crew instructions.

Medical Devices

Pacemakers

The Advanced Medical Technology Association (AdvaMed) recommends that a minimum separation of 15 centimeters (6 inches) be maintained between a handheld wireless radio and a pacemaker. These recommendations are consistent with those of the U.S. Food and Drug Administration. Persons with pacemakers should:

- ALWAYS keep the radio more than 15 centimeters from their pacemaker when the radio is turned ON.
- Not carry the radio in the breast pocket.
- Use the ear opposite the pacemaker to minimize the potential for interference.
- Turn the radio OFF immediately if you have any reason to suspect that interference is taking place.

Hearing Aids

Some digital wireless radios may interfere with some hearing aids. In the event of such interference, you may want to consult your hearing aid manufacturer to discuss alternatives.

Other Medical Devices

If you use any other personal medical device, consult the manufacturer of your device to determine if it is adequately shielded from RF energy. Your physician may be able to assist you in obtaining this information.

Use of Communication Devices While Driving

Always check the laws and regulations on the use of radios in the area where you drive.

- Give full attention to driving and to the road.
- Use hands-free operation, if available.
- Pull off the road and park before making or answering a call if driving conditions or regulations so require.

Operational Warnings



WARNING

For Vehicles With An Air Bag

Refer to vehicle manufacturer's manual prior to installation of electronic equipment to avoid interference with air bag wiring.

Do not place a portable radio in the area over an air bag or in the air bag deployment area. Air bags inflate with great force. If a portable radio is placed in the air bag deployment area and the air bag inflates, the radio may be propelled with great force and cause serious injury to occupants of the vehicle.

Potentially Explosive Atmospheres

(Explosive atmospheres refers to hazard classified locations that may contain hazardous gas, vapors, or dusts.)

Turn off your radio prior to entering any area with a potentially explosive atmosphere, unless it is a radio type especially qualified for use in such areas as "Intrinsically Safe" (for example, Factory Mutual, CSA, UL, CENELEC or ATEX Approved). Do not remove, install, or charge batteries in such areas. Sparks in a potentially explosive atmosphere can cause an explosion or fire resulting in bodily injury or even death.

The areas with potentially explosive atmospheres referred to above include fuelling areas such as below decks on boats, fuel or chemical transfer or storage facilities, areas where the air contains chemicals or particles, such as grain, dust or metal powders. Areas with potentially explosive atmospheres are often but not always posted.

Blasting Caps And Blasting Areas

To avoid possible interference with blasting operations, turn off your radio when you are near electrical blasting caps, in a blasting area, or in areas posted:

"Turn off two-way radio". Obey all signs and instructions.

Operational Cautions



Caution

Antennas

Do not use any portable radio that has a damaged antenna. If a damaged antenna comes into contact with your skin, a minor burn can result.

Batteries

All batteries can cause property damage and/or bodily injury such as burns if a conductive material such as jewelry, keys, or beaded chains touch exposed terminals. The conductive material may complete an electrical circuit (short circuit) and become quite hot. Exercise care in handling any charged battery, particularly when placing it inside a pocket, purse, or other container with metal objects.

Intrinsically Safe Radio Information

The Intrinsically safe approval unit refers to a product that has been approved as intrinsically safe by an approval agency (for example FM Approvals, CSA, UL, CENELEC or ATEX) and certifies that a particular product meets the Agency's applicable intrinsic safety standards for specific types of hazardous classified locations. A portable radio that has been approved for intrinsic safety will have Approval label attached to the radio to identify the unit as being Approved for specified hazardous atmospheres. This label specifies the hazardous Class/Division/Group along with the part number of the battery that must be used. The Intrinsically Safe Approval Label will be located on the portable radio unit.

Operational Cautions for Intrinsic Safe Equipment



Caution

- Do not operate radio communications equipment in a hazardous atmosphere unless it is a type especially qualified (for example, FM, UL, CSA, or CENELEC or ATEX approved). An explosion or fire may result.
- Do not operate a radio unit that has been approved as intrinsically safe product in a hazardous atmosphere if it has been physically damaged (for example, cracked housing). An explosion or fire may result.
- Do not replace or charge batteries in a hazardous atmosphere. Contact sparking may occur while installing or removing batteries and cause an explosion or fire.

Operational Cautions for Intrinsic Safe Equipment

Radios must ship from the Motorola manufacturing facility with the hazardous atmosphere capability and the intrinsic safety approval labelling (FM, UL, CSA, CENELEC or ATEX). Radios will not be upgraded to this capability and labeled once they have been shipped to the field.

A modification changes the unit's hardware from its original design configuration. Modifications can only be made by the original product manufacturer.



WARNING

- **Do not replace or change accessories in a hazardous atmosphere. Contact sparking may occur while installing or removing accessories and cause an explosion or fire.**
- **Turn the radio off before removing or installing a battery or accessory.**
- **Do not disassemble an intrinsically safe product in any way that exposes the internal circuits of the unit.**
- **Failure to use an intrinsically safe approved battery or Approved accessories specifically approved for the radio unit may result in the dangerously unsafe condition of an unapproved radio combination being used in a hazardous location.**
- **Unauthorized or incorrect modification of the intrinsically safe approved Product will negate the approval rating of the product.**
- **Incorrect repair or relabeling of any intrinsically safe Agency-approved radio could adversely affect the Approval rating of the unit.**
- **Use of a radio that is not intrinsically safe in a hazardous atmosphere could result in serious injury or death.**

Repair



WARNING

REPAIRS FOR MOTOROLA PRODUCTS WITH INTRINSICALLY SAFE APPROVAL ARE THE RESPONSIBILITY OF THE USER.

- **Repairs to a Motorola FM approved radio product should only be done at a location that has been FM audited under the FM 3605 repairs and service standard.**
- **Contact Motorola for assistance regarding repairs and service of Motorola intrinsically safe equipment.**

A repair constitutes something done internally to the unit that would bring it back to its original condition.

Items not considered as repairs are those in which an action is performed on a unit which does not require the outer casing of the unit to be opened in a manner which exposes the internal electrical circuits of the unit.

Do Not Substitute Options or Accessories

The Motorola communications equipment certified as intrinsically safe by the approving agency, (FM, UL, CSA, CENELEC or ATEX) is tested as a complete system which consists of the listed agency Approved portable, Approved battery, and Approved accessories or options, or both. This Approved portable and battery combination must be strictly observed. There must be no substitution of items, even if the substitute has been previously Approved with a different Motorola communications equipment unit. Approved configurations are listed by the Approving Agency (FM, UL, CSA, CENELEC or ATEX).

The Intrinsically Safe Approval Label affixed to radio refers to the intrinsically safe classification of that radio product, and the approved batteries that can be used with that system.

The manual PN referenced on the Intrinsically Safe Approval Label identifies the approved Accessories and or options that can be used with that portable radio unit.

Using a non Motorola intrinsically safe battery and or accessory with the Motorola approved radio unit will void the intrinsically safe approval of that radio unit.

CE European Union Directives Conformance Statement

This product is in conformance with the TETRA (TErrestrial Trunked RAdio) standard.
This product is in conformance with the requirements of the applicable EU Council Directives.
Declarations of Conformance with the requirements are located at:

Motorola a/s
Sydvestvej 15
DK-2600 Glostrup

Denmark

Notes

CONTENTS

COPYRIGHT	ii
DOCUMENT HISTORY	iii
SAFETY	v
CONTENTS	xiii
CHAPTER 1 SCOPE & WARRANTY	1-1
Scope of this Manual	1-1
Manual Revisions	1-1
Related Publications	1-1
Warranty and Service Support	1-2
After Warranty Period	1-2
CHAPTER 2 MODEL INFORMATION	2-1
MTH800 Model Information	2-1
MTH800 Model Specifications	2-2
CHAPTER 3 OVERVIEW	3-1
Digital Modulation Technology	3-1
Voice Compression Technology	3-1
Description	3-2
Transceiver Description	3-2
Digital Section Description	3-2
Transmitter Path Description	3-2
Receiver Path Description	3-3
Frequency Generating Section Description	3-3
Global Positioning System (GPS) Section Description	3-3
CHAPTER 4.1 TEST SETUP & TESTING 380-430MHz	4-1
Typical Test Setup	4-2
Alternative Test Setup	4-3
Test Check List	4-3
Transmitter Tests	4-4
Call Processing Tests	4-4
Duplex Test	4-5
How to Configure the IFR 2968 Setup	4-5
How to Configure the IFR 2968 Manual Test Screen	4-7
RF Tests	4-8
Receiver Tests	4-8

Simulate Base Station (registration)	4-8
RSSI Test.....	4-8
Transmitter Tests	4-9
Call Processing Test.....	4-10
Talk Back	4-10
Call to Mobile.....	4-10
Digital Duplex Test (Tx).....	4-11
Manual Mode Testing	4-12
Preparation for Testing	4-12
Tests	4-12
Charger Recognition Test.....	4-15
Service Flowchart.....	4-16

CHAPTER 4.2 TEST SETUP & TESTING 440-470MHz..... 4-1

Typical Test Setup.....	4-2
Alternative Test Setup	4-3
Test Check List.....	4-3
Transmitter Tests	4-4
Call Processing Tests	4-4
Duplex Test.....	4-5
How to Configure the IFR 2968 Setup	4-5
How to Configure the IFR 2968 Manual Test Screen	4-7
RF Tests	4-8
Receiver Tests.....	4-8
Simulate Base Station (Registration).....	4-8
RSSI Test.....	4-8
Transmitter Tests	4-9
Call Processing Test.....	4-10
Talk Back	4-10
Call to Mobile.....	4-10
Digital Duplex Test (Tx).....	4-11
Manual Mode Testing	4-12
Preparation for Testing	4-12
Tests	4-12
Charger Recognition Test.....	4-15
Service Flowchart.....	4-16

CHAPTER 5 PROGRAMMING THE TERMINAL 5-1

CHAPTER 6 MAINTENANCE..... 6-1

Preventive Maintenance.....	6-1
Inspection	6-1
Cleaning	6-1
Cleaning External Plastic Surfaces	6-2
Cleaning Internal Circuit Boards and Components.....	6-2
Safe Handling of CMOS Devices	6-2
Pre-baking of Integrated Circuits.....	6-3
Baking Precautions for TETRA Power Amplifiers (PAs).....	6-3
Level 1 and Level 2 Maintenance	6-4

Disassembling and Reassembling the MTH800 Unit.....	6-4
Protecting Static-Sensitive Devices.....	6-4
To create a proper ground	6-5
To store or transport a circuit board.....	6-5
Removing and Installing the Antenna	6-5
To remove the antenna from the unit.....	6-5
To install the antenna in the unit.....	6-6
Removing and Installing Battery Door and Battery	6-6
To remove the battery door from the unit	6-6
To remove the battery.....	6-6
To install the battery.....	6-7
To install the battery door	6-7
Removing and Installing the Audio Assembly Cap.....	6-8
To remove the audio assembly cap from the unit.....	6-8
To install the audio assembly cap onto the unit.....	6-8
Removing and Installing the Back Housing.....	6-9
To remove the back housing from the unit	6-9
To install the back housing	6-11
Removing and Installing the Vibrator	6-11
To remove the vibrator.....	6-11
To install the vibrator.....	6-11
Removing and Installing the Main Board.....	6-11
To remove the main board from the unit.....	6-11
To install the main board.....	6-12
Removing and installing the UCM Board	6-14
To remove the UCM board from the main board	6-14
To install the UCM board on the main board	6-15
Removing and installing the Display	6-15
To remove the display from the unit	6-15
To install the display	6-17
Removing and Installing the Display Board.....	6-17
To remove the display board from the unit	6-17
To install the display board	6-18
Removing and Installing the Accessory Connector Assembly	6-18
To remove the accessory connector.....	6-19
To install the accessory connector.....	6-19
Removing and Installing the Keypad.....	6-20
To remove the keypad	6-20
To install the keypad	6-21
Removing and Installing the Rotary Switch.....	6-21
To remove the rotary switch.....	6-21
To install the rotary switch	6-21
Removing and Installing the Microphones	6-22
To remove the top microphone from the unit.....	6-22
To install the top microphone.....	6-22
To remove the bottom microphone from the unit.....	6-22
To install the bottom microphone.....	6-23
Removing and Installing the Earpiece.....	6-23
To remove the earpiece from the unit.....	6-23
To install the earpiece.....	6-23
MTH800 Unit - Exploded View	6-24
MTH800 Components List.....	6-24

Torque List	6-26
Replacement Parts	6-29
Terminal Replacement Parts List	6-29
Accessories Replacement Parts List	6-31
APPENDIX A SERVICE INFORMATION	A-1
Replacement Parts	A-1
Level 3 Maintenance	A-1
Service Information	A-1
European Radio Support Centre (ERSC)	A-1
EMEA Systems Support Centre (ESSC)	A-2
European Systems Component Centre (ESCC)	A-2
Parts Identification and Ordering	A-2
EMEA Test Equipment Support	A-2
Asia, Pacific Region	A-3
Technical Support	A-3
Further Assistance From Motorola	A-3
Piece Parts	A-3
Latin America Region	A-4
Recommended Programming Equipment	A-6
Service Replacement Kit Matrix	A-6
APPENDIX B CONNECTOR PIN FUNCTIONS	B-1
CE Bottom Connector	B-1
Mode Select (Option1 and Option2):	B-2
Accessory Connector Pin-Outs	B-2
AUDIO Side Connector	B-3
PHF/RSM Connector	B-3
PHF/RSM Plug	B-3
RSM Modes of Operation	B-4

CHAPTER 1

SCOPE & WARRANTY

Scope of this Manual

This manual contains information necessary to test and maintain the MTH800 TETRA Handportable Terminal at the module level. It also contains information on radio assembling and disassembling. Accordingly, information in this manual is divided into the following sections:

- Copyright
- Safety
- CHAPTER 1 Scope & Warranty
- CHAPTER 2 Model Information
- CHAPTER 3 Overview
- CHAPTER 4 Test Setup & Testing
- CHAPTER 5 Programming the Radio
- CHAPTER 6 Maintenance
- APPENDIX A Service Information
- APPENDIX B Connector Pin Functions

Manual Revisions

Changes which occur after this manual is printed are described in Manual Revisions. These Manual Revisions provide complete information on changes including pertinent parts listing data.

Related Publications

- 6802972C30 MTH800 Basic User Guide (EN, DE, FR, ES, NL)
- 6866537D97 MTH800 Basic User Guide (EN, SV, RU, IT, PL, DK, AR)
- 6802972C35 MTH800 Feature User Guide
- 6866539D22 MTH800 Basic Service Manual
- 6802972C45 MTH800 Detailed Service Manual 380-430MHz NON EPP
- 6866539D15 MTH800 Detailed Service Manual 380-430MHz EPP
- 6866539D23 MTH800 Detailed Service Manual 440-470MHz
- 6802974C10 CPS User's Guide
- 6866539D26 Installation Manual for UCM-M Upgrade Kit GMLN4561
- IFR-Operational Manual Supplement 46882-324
- IFR-Operational Manual 46882-274T

Warranty and Service Support

Motorola offers long term support for its products. This support includes full exchange and/or repair of the product during the warranty period, and service/ repair or spare parts support out of warranty. Warranty Period and Return Instructions

The terms and conditions of warranty are defined fully in the Motorola Dealer or Distributor or Reseller contract. These conditions may change from time to time and the following notes are for guidance purposes only. In instances where the product is covered under a "return for replacement" or "return for repair" warranty, a check of the product should be performed prior to shipping the unit back to Motorola. This is to ensure that the product has been correctly programmed or has not been subjected to damage outside the terms of the warranty.

Prior to shipping any radio back to the appropriate Motorola warranty depot, please contact Customer Resources or your Motorola dealer, distributor or reseller. All returns must be accompanied by a Warranty Claim Form, available from your Customer Service representative or Motorola Online Extranet (MOL) or your Motorola dealer, distributor or reseller (refer to list in Appendix A). Products should be shipped back in the original packaging, or correctly packaged to ensure no damage occurs in transit.

After Warranty Period

After the Warranty period, Motorola continues to support its products in two ways.

- Motorola's Regional Radio Support Centers offer a repair service to both end users and dealers at competitive prices.
- AAD supplies individual parts and modules that can be purchased by dealers who are technically capable of performing fault analysis and repair.

CHAPTER 2 MODEL INFORMATION

MTH800 Model Information

This manual applies to the following MTH800, 1 W, TETRA Handportable Terminal model:

H78PCN6TZ5AZ 380-430 MHz
H78RCN6TZ5AZ 440-470 MHz

Model Numbering System

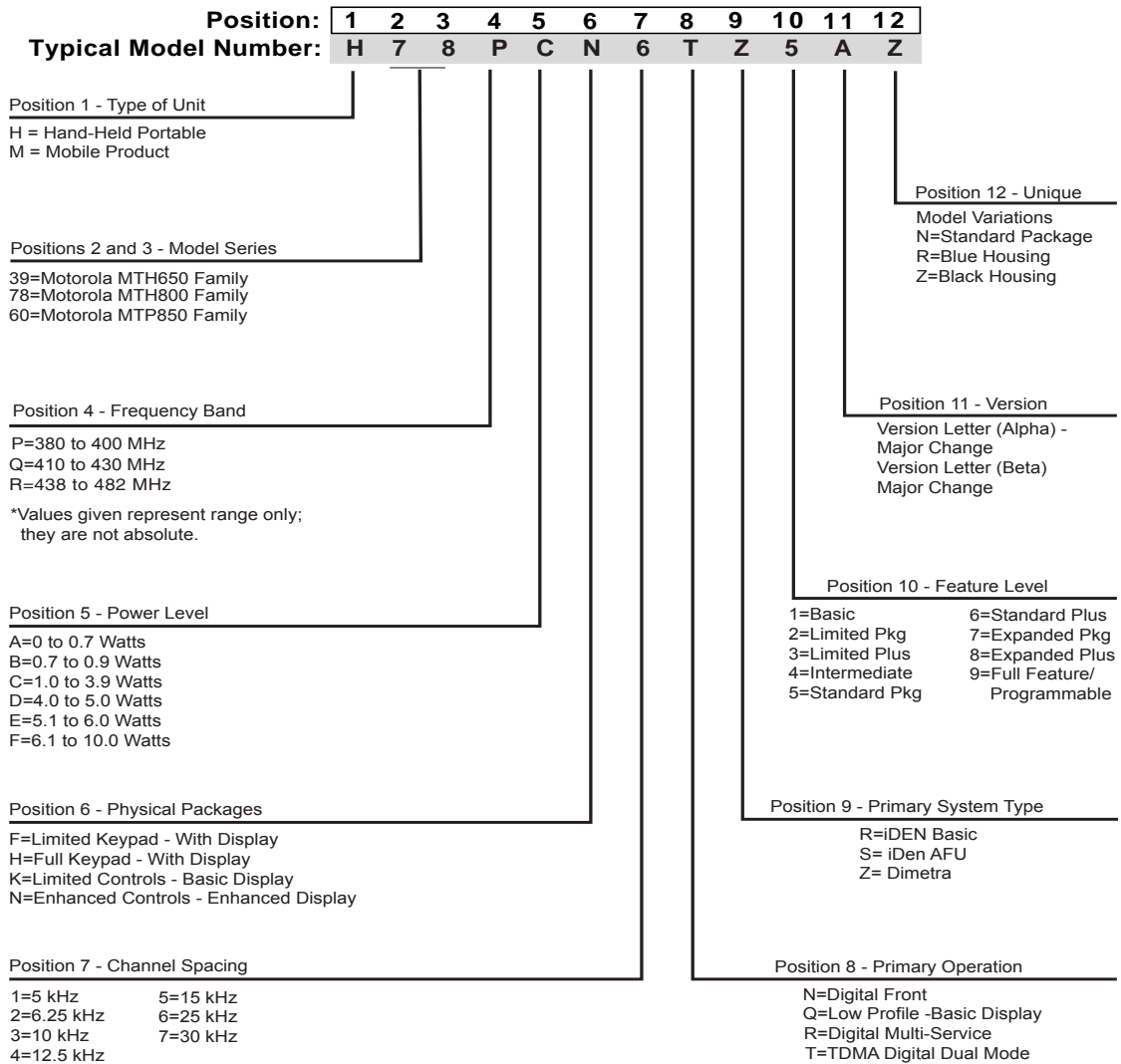

MTH800 Model Specifications

GENERAL		RECEIVER		TRANSMITTER	
ETSI	ETS 300 019-1-7	Receiver Type:	Class A and B	Modulation Type:	$\pi/4$ DQPSK
Type Number:	380-430 MHz 440-470 MHz	Frequency Range:	380-430 MHz 440-470 MHz		
Temperature Range for Transceiver:		Channel Spacing:	25 kHz	RF Power:	1 Watt
Operating:	-30°C to +60°C	Sensitivity (4%) BER:	-112 dBm		
Storage:	-40°C to +85°C	Intermodulation:	(4%) BER	Frequency Range:	380-430 MHz 440-470 MHz
		Interfering Signal Level:	-47 dBm		
Battery Types:	SNN5705 800 mAh (Li Ion) NNTN4655 1500 mAh (Li Ion)	Selectivity Blocking: (50-100 kHz)	(4%) BER	Frequency Stability:	Locked to Base ± 100 Hz Not Locked to Base ± 2 ppm
		Interfering Signal Level:	-40 dBm		
Battery Voltage:		Spurious Rejection:	(4%) BER	Spurious Emissions:	
Minimum:	3.4 Vdc	Interfering Signal Level:	-45 dBm	<u>Conducted</u>	
Nominal:	3.8 Vdc			30MHz-1GHz	-36dBm
				1GHz-4GHz	-30dBm
				<u>Radiated</u>	
				30MHz-1GHz	-36dBm
				1GHz-4GHz	-30dBm
Portable Dimensions HxWxD:	141x55x32 mm	Frequency Stability:		Adjacent Channel Power (at ± 25kHz):	55dBc
Weight:	192 gr, without battery	Locked to Base:	± 100 Hz		
		Unlocked to Base:	2.0 ppm		
		Audio Rated:	1 W		
		Distortion at Rated Audio:	15% Max.		

Specifications subject to change without notice.

CHAPTER 3 OVERVIEW

To achieve a high spectrum efficiency, the MTH800 uses digital modulation technology and sophisticated voice-compression algorithm. The voice of the person speaking into the microphone is converted into a digital bit stream consisting of zeros (0) and ones (1). This stream is then modulated into a radio-frequency (RF) signal, which is transmitted over the air to another terminal. The process is called digital modulation.

Digital Modulation Technology

The MTH800 is a 380-430 or 440-470MHz TETRA Handportable Terminal that can operate in dispatch and phone modes. The terminal can also operate in TMO (Trunked Mode Operation) and DMO (Direct Mode Operation) modes. It uses two digital technologies: $\pi/4$ DQPSK and Time Division Multiple Access (TDMA).

$\pi/4$ DQPSK is a modulation technique that transmits information by altering the phase of the radio frequency (RF) signal. Data is converted into complex symbols, which alter the RF signal and transmit the information. When the signal is received, the change in phase is converted back into symbols and then into the original data.

The system can accommodate 4-voice channels in the standard 25 kHz channel as used in the two-way terminal.

Time Division Multiple Access (TDMA) is used to allocate portions of the RF signal by dividing time into four slots, one for each unit.

Time allocation enables each unit to transmit its voice information without interference from other transmitting units. Transmission from a unit or base station is accommodated in time-slot lengths of 15 milliseconds and frame lengths of 60 milliseconds. The TDMA technique requires sophisticated algorithms and a digital signal processor (DSP) to perform voice compressions/decompressions and RF modulation/demodulation.

Voice Compression Technology

Voice is converted into a digital bit stream by sampling the voice at a high rate and converting the samples into numbers, which are represented by bits.

Voice compression reduces the number of bits per second while maintaining the voice at an acceptable quality level. The MTH800 uses a coding technique called ACELP (Algebraic Code Excited Linear Prediction). The compressed voice-data bits modulate the RF signal.

Description

Transceiver Description

All the terminal circuitry is contained in the Digital/RF Board and the keypad board. The Digital/RF board is divided into the following sections: digital, frequency generating, transmitter, and receiver.

Digital Section Description

The digital section includes the Patriot IC that consists of the Mcore risk machine and the Digital Signal Processor (DSP).

The Mcore is the controller of the Digital/RF Board. It controls the operation of the transmitter, receiver, audio, and synthesizer integrated circuits located in the RF section. It communicates with the keypad and display.

The Digital Signal Processor (DSP) performs modulation and de-modulation functions for the terminal. It also performs Forward Error Correction and other correction algorithms for overcoming channel errors and ACELP speech coding. It carries out linear 10-bit analog to digital conversions, audio filtering, and level amplification for the microphone audio input and the received audio output.

The power and audio section is based on the GCAP III and includes power supplies, 13-bit CODEC, audio routing, microphone and ear piece amplifiers. A audio power amplifier is used for the loud speaker.

Transmitter Path Description

The transmitter circuitry includes a linear class AB Power Amplifier (PA) for the linear modulation of the MTH800. It includes a cartesian feedback loop to enhance its transmitter linearity and reduced splattering power into adjacent channels.

The transmitter path consists of a cartesian feedback loop that contains the forward and loop feedback paths.

The forward path includes the JAVELIN IC, BALUN, Attenuator, Power Amplifier and Isolator.

The loop feedback path includes the directional coupler, attenuator, BALUN, and JAVELIN IC.

The cartesian Feedback output power passes to the antenna through the Isolator, Antenna Switch, Harmonic Filter and Duplexer.

Receiver Path Description

The receiver section in MTH800 is based on the novel DCR (Direct Conversion) technology, the main concept of this technology is down converting of the RF signal directly into a base band signal, skipping the intermediate stage of IF signal.

The receiver path includes the Antenna Switch, Limiter, 10dB Step Attenuator, Tunable Filter, LNA integrated with 28dB Step Attenuator and 40dB of AGC continuous attenuation, Pre-selector Band Pass Filter, Balun, Half-Life Mixer, 1-pole filter, and the Tomahawk IC which consists of all the base band receive chain.

Frequency Generating Section Description

The frequency generating section provides description of the following main components: Tomahawk IC fractional-N Synthesizer, Escort synthesizer, Reference oscillator, Main VCO, Tx VCO and buffer.

Global Positioning System (GPS) Section Description

The GPS section includes the following main components: Duplexer, Front filter, LNA, Post Filter, Instant GSCi-5000 IC, RTC, and TCXO.

The GPS in the MTH800 is based on the SIRF GSCi-5000 IC, which comprises a standalone ROM-based multimode GPS receiver in a single chip BGA Package.

Notes

CHAPTER 4.1

TEST SETUP & TESTING 380-430MHz

**Caution**

Any level 3 repairs can deeply affect the performance of the MTH800 and may cause a new tuning procedure. This tuning procedure can be applied by certain authorised Motorola depots where the appropriate TEST & TUNE EQUIPMENT is available. The appropriate TEST & TUNE EQUIPMENT is a special automated test equipment which is only available at some Motorola factories and Motorola repair centers.

**Caution**

Do not use FLN9659 for testing MTH800

Typical Test Setup

Note: Check with your Motorola local representative for the availability of Cradle FTN6308 required for this type of testing, it is part of Digital Car Kit FTN6307.

Carry out the following instructions before testing:

- Check that you have a fully charged battery (not required when using Battery Eliminator WALN4097).
- Install the MTH800 into the FTN6308 Digital Car Kit cradle.
- Connect RF cable 3086228J02 to the N-type RF Connector of the IFR.
- Connect the other side of the RF cable to the cradle's RF connector.

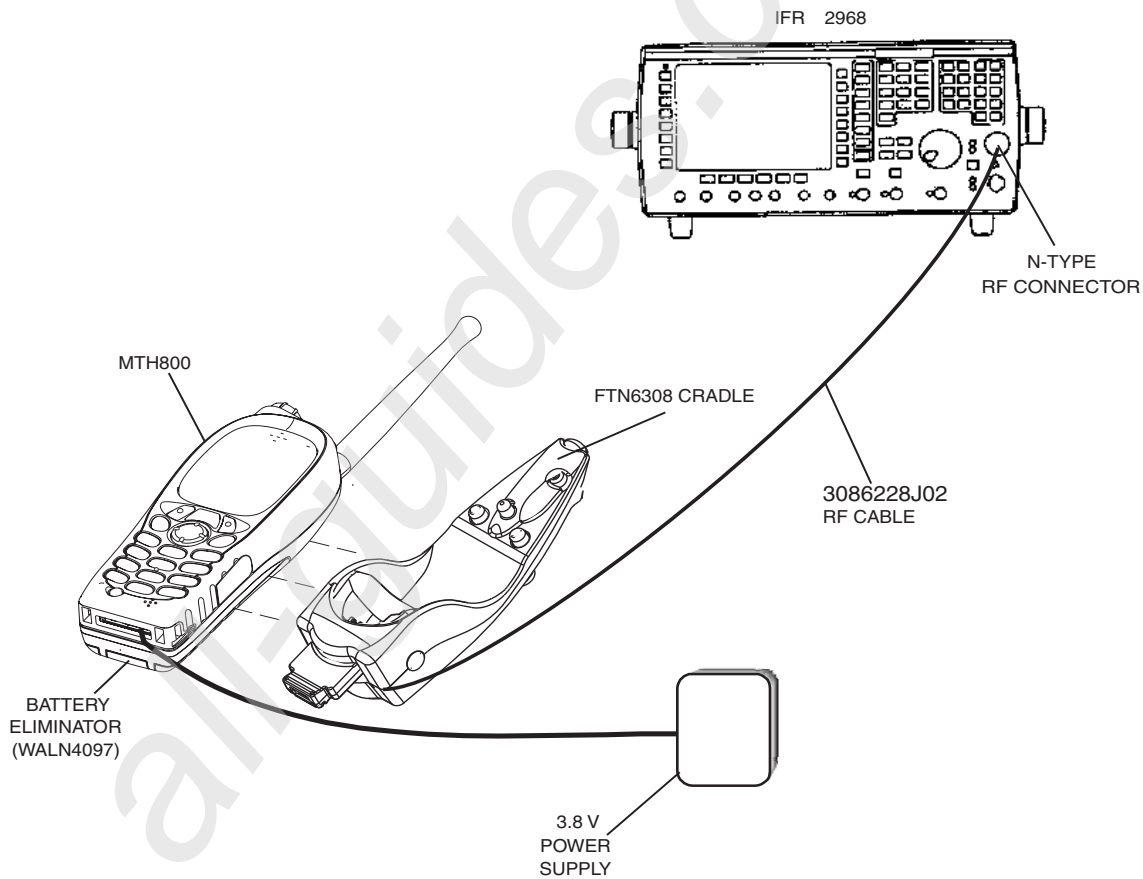

Figure 1. Typical Test Setup

Alternative Test Setup

Cable adapter 2888482K04 enables connecting to the vehicle adapter connector on a stand-alone main board. Thus, it allows testing of the main board in a disassembled unit. One side, the cable adapter has a mating vehicle adapter connector with mechanical grasping mechanism; on the other side the connection is SMA male.

Test Check List

The following table summarises the required test setups.

No.	Test Name	Test Setup	Terminal Setup	Test Conditions	Limits
1.	Base Station Registration				
		Control Channel	422.0125 MHz	880	TETRA 410MS
		Traffic Channel	422.0125 MHz	880	TETRA 410MS
		Time Slot		3	
		Country Code		753	
		Network Code		2361	
		Base Color		1	
		Location Area		23	
		Min Rx Level			-110dBm
		Max Tx Level			30dBm
		Access Parameter		-53dBm	
		Mobile Power	30dBm		
		Burst Type		Normal	
2.	Transmitter Burst Power				
		RF Gen Level Burst Power		-90dBm	28-32dBm
		Timing Error			<=0.25 Symbols
		Vector Error			Max 10% RMS, 30% Peak
		Frequency Error			-/+ 100Hz

No.	Test Name	Test Setup	Terminal Setup	Test Conditions	Limits
3.	Call Processing Talk Back				
		1KHz Test Signal Group Mode		-50dBm	
4.	Call Processing Call to Mobile				
		Private	4 digit random number & "Send"		28-32dBm
		RF Gen Level Burst Power		-90dBm	28-32dBm
		Timing Error			<=0.25 Symbols
		Vector Error			Max 10% RMS, 30% Peak
		Frequency Error			-/+ 100Hz

Transmitter Tests

1. Power Burst (Control Range)
2. Power Profiles
3. Tx Burst Timing Error
4. Vector Error RMS and Peak
5. Tx Frequency Error

Call Processing Tests

1. Talk Back
2. Call to Mobile

Duplex Test

1. Digital Duplex Test (Tx)

Measurement Capabilities:

Bar charts (Tx Power, Freq. Err, Vector Rms.), Spectrum Analyser, Power Analyser, Vector Analyser, Vector Diagrams

How to Configure the IFR 2968 Setup

Perform the following steps to configure the IFR 2968 with the terminal set:

1. Turn ON the IFR.
2. Press "Systems" Mode Key (wait until the digital system is initialised).
3. Press the "Tetra Mobile" softkey.
4. Press the "Setup" softkey and enter the System Parameters Screen.
5. Press the "Channel Plan" softkey.
6. Press "Tetra 410MS" softkey. The "Control Channel" automatically changes to "800"; and "Traffic Channel" automatically changes to 900.
7. Press twice the "Traffic Channel" softkey and check that the marker goes to Timeslot. Press Data key "3" followed by the "Traffic Channel" softkey, to change to Timeslot "3".
8. Press "Country Code" softkey. Enter "753" and "Country Code" softkey.
9. Press "Network Code" softkey. Thereafter, enter "2361" and press "Network Code" softkey.
10. Press "Base Color" softkey. Thereafter, enter "1" and press "Base Color" softkey.
11. Press "Location Area" softkey. Thereafter, enter "23" and press "Location Area" softkey.
12. Press "More" softkey. Press "Min Rx Level" softkey. Thereafter, enter "-110dBm" and press "Min Rx Level" softkey.
13. Press "Max Tx Level" softkey. Thereafter, enter "30dBm" and press "Max Tx Level" softkey.
14. Press "Access Parameter" softkey. Thereafter, enter "-53dBm" and press "Access Parameter" softkey.
15. Press "Base Service" softkey and "Supported" softkey

Note: You are entering base services setup.

If the displayed values are different, please change the IFR setting to be similar to the values below.

Power On Registration: required

Power Off Deregistration: required

Priority Cell: yes

Minimum Mode Service: never used

Migration: not supported

System Wide Services: normal mode

16. Press "More" softkey.

TETRA Voice Service: supported

Circuit Mode Data Service: not supported

(Reserved): not available

SNDCD Service: not available

Air Interface Encryption: not available

Advanced Link: not supported

17. Press the "Return" softkey.

18. Press the "Neighbr Cell" softkey.

19. Verify that the following NEIGHBOUR CELL INFO values are displayed:

Note: If the displayed values are different, please change the IFR setting to be similar to the values below.

NEIGHBOUR CELL BROADCAST: SUPPORTED

BROADCAST INTERVAL: 10s

NEIGHBOUR CELL CHANNEL: 0000

NEIGHBOUR CELL LOCATION AREA: 00001

NEIGHBOUR CELL IDENTIFIER: 01

SLOW RE-SELECT THRESHOLD: 10dB

PRESS "MORE" softkey

SLOW RE-SELECT HYSTERESIS: 10dB

FAST RE-SELECT THRESHOLD: 10dB

FAST RE-SELECT HYSTERESIS: 10dB

20. Press the "Return" softkey.

21. Press the "Trunk Type" softkey and "Tx Trunked" softkey (Transmission).

22. Press "More" Softkey.

Note:

The displayed values are factory defaults and should not be changed.

It is not required to configure "Call Types" "Call Times" and "Messages".

23. Press "More" Softkey.

How to Configure the IFR 2968 Manual Test Screen

1. To enter "Manual test" screen, press "Manual" softkey.
2. Press "Control Channel" softkey. Thereafter, "880" and press "Control Channel" softkey (IFR 880 = Rx 422.0125MHz).
3. Press "Traffic Channel" softkey. Enter "880" and press "Traffic Channel" softkey. The marker goes to Timeslot. Enter "3" and press "Traffic Channel" softkey. (Note that the Traffic Channel number changes automatically after entering the Control Channel number).
4. Press "RF Gen Level" softkey. Thereafter, enter "-50" and press "dBm" data keys.
5. Press "Mobile Power" softkey, press "+5dB step" or "-5dB step" softkey to reach 30 dBm/1W. Make sure the "Mobile Power" either in "expected level" or "close loop".
6. Press "return". Press "Burst Type" softkey and "Normal" softkey.
7. This completes the test equipment configuration setup.

Note: The System Setup Configuration Data is saved even after the power is turned off. However, the Manual Test Setup is not saved.

RF Tests

Receiver Tests

Simulate Base Station (registration)

NOTE: This test requires programming the terminal. Refer to 6802974C10 TETRA Customer Programming Software (CPS) for MTH800.

1. Via the Depot version CPS, enable the Test Page field in the terminal codeplug and program the terminal.
2. Turn the terminal ON.
3. Check that registration and "GSSI:xxxxxx selected" is displayed on the IFR "Manual Test" screen.

RSSI Test

Before carrying out the following steps, record the Insertion loss (dB) of the cable loss value - (X) dB. Also, 0.5 dB, the maximum insertion loss of the Antenna assembly adapter should be added to the total calculated insertion loss.

1. In the IFR Manual Test Mode, press the "RF Gen Level" softkey and enter "-80dBm".
2. Before testing, the terminal should be configured to RSSI mode using the following sequence. When performing steps 3 thru 6, make sure that you press the handset keys sequentially (less than a second between every consecutive press).
3. Press the "Star" Key.
4. Press the "#" Key.
5. Press the "Menu" Key.
6. Press the "Right Arrow" Key.
7. Scroll to "Cells Info".
8. Press the "Select" softkey.
9. Press the "Right Arrow" Key.
10. Press the "Trace" softkey.

Note: RSSI results will flash on the screen every few seconds.

The display shows: SERV: xx

RSSI: -81

SQE: xx

Disregard the "SERV" and "SQE" results.

The actual measured result should be:

{-80dBm (IFR RF Gen Level) -0.5dB(adapter)-XdB (cable)} +/-1 dB.

RSSI = {Radio RSSI Result – [Antenna assembly Adapter (dB) + Insertion loss of the Cable (dB)]}.

To stop the "Trace" process, perform the following. When performing steps 11. thru 14., make sure that you press the handset keys sequentially (less than a second between every consecutive press):

11. Press the "Star" Key.
12. Press the "#" Key.
13. Press the "Menu" Key.
14. Press the "Right Arrow" Key.
15. Scroll to "Cells Info"
16. Press the "Select" softkey.
17. Press the "Stop" softkey.
Press twice the "Back" softkey.

Transmitter Tests

1. Verify that your terminal is in "Group Mode".
2. Press the "RF Gen Level" softkey. Enter "-90dBm" by pressing the data keys and "RF Gen Level" Key.
3. Press the "PTT" of the terminal and monitor the IFR "Manual Test" screen which displays the Burst Power, Power Profile, Timing Error, Vector Error, and Frequency Error.

Note: You have to hold the PTT in the pressed position long enough to enable you to read the results.

- Burst Power Required Results: 28-32dbm.
- Power Profile: Passed.
- Timing Error: ≤ 0.25 symbols.

- Vector Error: Max 10% RMS, Max 30% Peak.
 - Max 5% residual.
 - Frequency Error: -/+ 100Hz.
4. Press the "Clear Down" softkey, to proceed with other tests.

Call Processing Test

Talk Back

Before you start this test, make sure that handset and test equipment are configured the same as given in the Transmitter Test.

1. Press and hold the "PTT" then press "talk back" softkey and speak into the mic of the terminal. Release the "PTT" and you will hear your speech.
2. Press the "silence" softkey to stop the speech.
3. Press and hold the "PTT" then press the "Test Sound" softkey to provide the 1kHz signal to the terminal speaker.
4. Release the "PTT", you will hear a 1kHz tone from the terminal speaker continuously.
5. Press the "Silence" softkey to mute the 1kHz Audio Signal of the speaker.
6. Press the "Clear Down" softkey and check that the "Cleardown Complete" status appear on the IFR "Manual Test" screen.

Call to Mobile

1. Press the "Call Mobile" softkey on the IFR.

Note: Select type of call.

2. Press "Private Call" softkey to select Private Call.

Note: You will hear beeps from the handset speaker.

3. Press "Abort Call" softkey. Duplex Test (Phone/Privet Mode)

Note: Repeat step 1 through 3 for "Phone Call" and "Emergency Call".

Digital Duplex Test (Tx)

1. Perform the following test in "Phone" or "Private" mode.
2. Dial a random number "9359" using the Alphanumeric keys of the terminal and press the "Send" Key.

The following results are displayed on the IFR "Manual Test" Screen.

- Burst Power Required Results: 28-32dbm
- Power Profile: Passed
- Timing Error: <0.25 Symbols.
- Vector Error: Max 10% RMS, Max 30% Peak.
- Max 5% residual.
- Frequency Error: -/+ 100Hz

3. Press the "talk back" softkey. Place the internal earpiece close to your ear. Speak into the handset microphone and hear your speech (after a short delay) from the handset internal earpiece.

Note: If you need more details, press the "Duplex Test" mode key.

4. Press the "duplex test (Tx)" softkey.

The "Digital Duplex test" results will be displayed on the IFR screen providing you with the following bar charts measurement capabilities:

- Power
- Vector RMS
- Frequency Error

For Power Analyser Graph:

5. Press "power ana" softkey.
6. Check that the power frame falls within the limits.

For Spectrum Analyser Graph:

7. Press "Spec ana" softkey.
8. Monitor the Tx frequency.

For Vector Analyser Diagram:

9. Press the "Vec Anal" softkey
10. Monitor the constellation diagram.

11. Press the "Vector Diagram" softkey.
12. Press the "Rotated vector" to zoom in on the constellation.
13. Press the handset "End" key.

Manual Mode Testing

Preparation for Testing

1. Verify that the terminal is turned off.
2. Press the "4", "5" and "6" keys together and then, press the On/Off key to turn the terminal on.
3. The display shows "LCD Color test Press Any Key To Proceed".

Tests

1. Press any key consecutively. The display shows horizontal red lines that becomes thicker with every key press, until it becomes fully red.
2. Press any key again, the display shows four colored rectangles.
3. Press any key consecutively. The display shows vertical green lines that becomes thicker with every key press, until it becomes fully green.
4. Press any key again. The display becomes fully blue and the message "END LCD test !!!" appears.
5. Press any key again. The display shows "Battery Interface Test".
6. Press any key again. The display shows "Battery Interface Test PASS".
7. Press any key again. The display shows "Vibrator On", verify that the terminal is vibrating.
8. Press any key again. The display shows "Red Led on" and the Red LED at the top of the terminal is lit.
9. Press any key again. The display shows "Green Led on" and the Green LED at the top of the terminal is lit.
10. Press any key. The display shows "Both Leds on" and the LED located on the top of the terminal is blinking in amber (combination of red and green lights of the two halves of the LED).
11. Press any key again. The display shows "Keypad Backlight On" and the keypad backlight is On.

12. Press any key again. The display shows "Display Backlight On" and the display backlight is On.

Note: The following readings appears only when a Universal Crypto Module (UCM) board is installed in the unit.

13. Press any key again. The display shows "UCM Detected".
14. Press any key again. The display shows "UCM Power up Success".
15. Press any key again. The display shows "UCM Wake Up Success".
16. Press any key again. The display shows "UCM Ping Success".

Note: The following reading appears only when a UCM board is not installed in the unit.

17. Press any key again. The display shows "UCM Not Detected".
18. Press any key again. The display shows "Speaker Tone Test", a tone is heard via the speaker.
19. Press any key again. The display shows "Internal Earpiece Tone Test", a tone is heard via the internal earpiece.
20. Press any key again. The display shows "Connect PHF for the following Tests". Insert a headset into the PHF connector and plug the PHF earpiece into your ear.
21. Press any key again. The display shows "PHF Earpiece Tone Test". A tone is heard via the PHF earpiece.
22. Press any key again. The display shows "Connect RSM-CE for the following Tests". Connect the RSM to the CE connector.
23. Press any key again. The display shows "RSM-CE Connector Tone Test". A tone is heard via the RSM speaker.
24. Press any key again. The display shows "INT MIC to INT EAR Loopback Test". Place the internal earpiece close to your ear. Speak into the internal MIC, and you will hear your voice via the internal earpiece.
25. Press any key again. The display shows "Connect PHF for the following Tests". Insert a headset into the PHF connector and plug the PHF earpiece into your ear.
26. Press any key again. The display shows "TOP Mic to PHF EAR Loopback Test". Speak into the top microphone, and you will hear your voice via the PHF earpiece.
27. Press any key again. The display shows "PHF Mic to PHF EAR Loopback Test". Speak into the PHF microphone, and you will hear your voice via the PHF earpiece.
28. Press any key again. The display shows "Connect RSM-CE for the following Tests". Connect the RSM to the CE connector.

29. Press any key again. The display shows "RSM-CE connector MIC to INT EARP Loopback Test". Place the internal earpiece close to your ear. Speak into the RSM mic, and you will hear your voice via the internal earpiece.
30. Press any key again. The display shows "Connect PHF for the following Tests". Insert a headset into the PHF connector and plug the PHF earpiece into your ear.
31. Press any key again. The display shows "Chopper-Noise Test INT MIC to PHF EAR". Listen for chopper noise via the PHF earpiece. Make sure chopper noise is not audible.
32. Press any key again. The display shows "Chopper-Noise Test TOP MIC to PHF EAR". Listen for chopper noise via the PHF earpiece. Make sure chopper noise is not audible.
33. Press any key again. The display shows "Chopper-Noise Test PHF MIC to PHF EAR". Listen for chopper noise via the PHF earpiece. Make sure chopper noise is not audible.
34. Press any key again. The display shows "Connect RSM-CE for the following Tests". Connect the RSM to the CE connector.
35. Press any key again. The display shows "Chopper-Noise Test RSM-CE connector MIC to INT EAR". Place the internal earpiece close to your ear and listen for chopper noise from the internal earpiece. Make sure chopper noise is not audible.
36. Press any key again. The display shows "Chopper-Noise TOP MIC to RSM-CE connector SPKR". Place the RSM speaker close to your ear and listen for chopper noise. Make sure chopper noise is not audible.
37. Press any key again. The display shows all the terminal keys.
38. Press every key, one by one. Each key you press causes its respective display to disappear.
39. Press any key to continue.
40. Press the  (navigator) key. Every time you press causes the respective display to disappear.
41. After pressing all keys, the display is clear.
42. Press any key to continue. The display shows "Rotary test". Turn the rotary switch clockwise. Each click causes the respective clockwise arrow sign to disappear. Then, a set of counter clockwise arrows appear. Turn the rotary switch counter clockwise. Each click causes the respective counter clockwise arrow sign to disappear. The display shows "Press the rotary".
43. Press the rotary.
44. This completes the test. Press any key to turn the terminal OFF.

Charger Recognition Test

- Turn the terminal ON.
- Connect the Rapid Travel Charger accessory connector to the handset. Check whether the LCD display shows “charger connected” and that the keypad back-light is turned ON.
- Connect the Vehicle Power Adapter (VPA) Charger accessory connector to the handset. Check whether the LCD display shows “charger connected” and that the keypad back-light is turned ON.
- Connect the handset to the Desktop Charger. Check whether the LCD display shows “charger connected” and that the keypad back-light is turned ON.
- Place the handset in the Digital Car Kit cradle. Verify that the car ignition switch is turned ON. Check whether the LCD display shows “Car Kit connected”, and that the keypad back-light is turned ON.
- Verify that the battery charger is in progress (the process advance is indicated on the Battery Strength icon).

Press the “ON/OFF” key. The terminal should turn OFF.

Service Flowchart

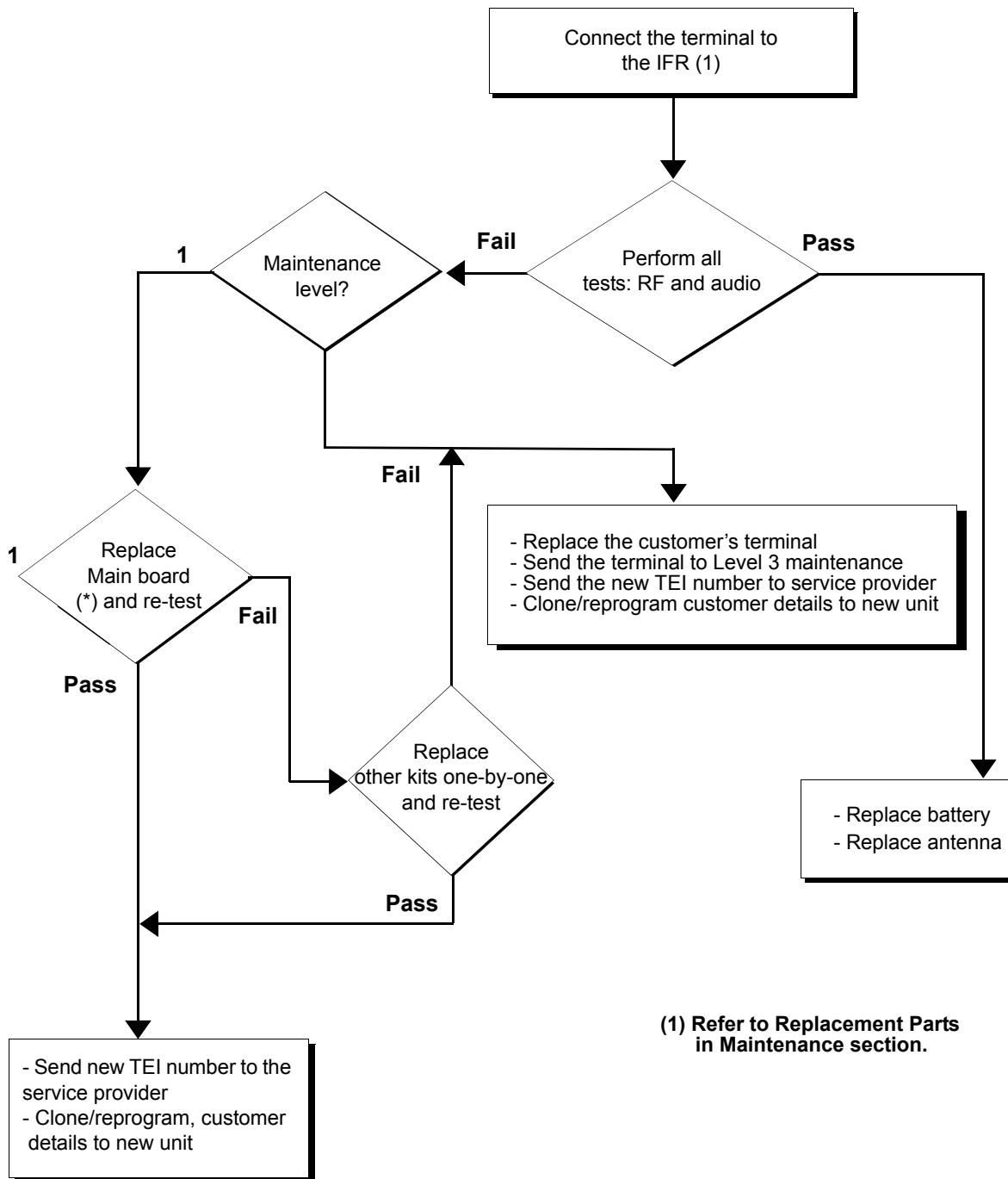

(1) Refer to Replacement Parts in Maintenance section.

(*) Main Board: See Service Replacement Kit (Appendix A)

Note: Not field replaceable for Latin America

CHAPTER 4.2

TEST SETUP & TESTING 440-470MHz

**Caution**

Any level 3 repairs can deeply affect the performance of the MTH800 and may cause a new tuning procedure. This tuning procedure can be applied by certain authorised Motorola depots where the appropriate TEST & TUNE EQUIPMENT is available. The appropriate TEST & TUNE EQUIPMENT is a special automated test equipment which is only available at some Motorola factories and Motorola repair centers.

**Caution**

Do not use FLN9659 for testing MTH800

Typical Test Setup

Note: Check with your Motorola local representative for the availability of Cradle FTN6308 required for this type of testing, it is part of Digital Car Kit FTN6307.

Carry out the following instructions before testing:

- Check that you have a fully charged battery (not required when using Battery Eliminator WALN4097).
- Install the MTH800 into the FTN6308 Digital Car Kit cradle.
- Connect RF cable 3086228J02 to the N-type RF Connector of the IFR.
- Connect the other side of the RF cable to the cradle's RF connector.

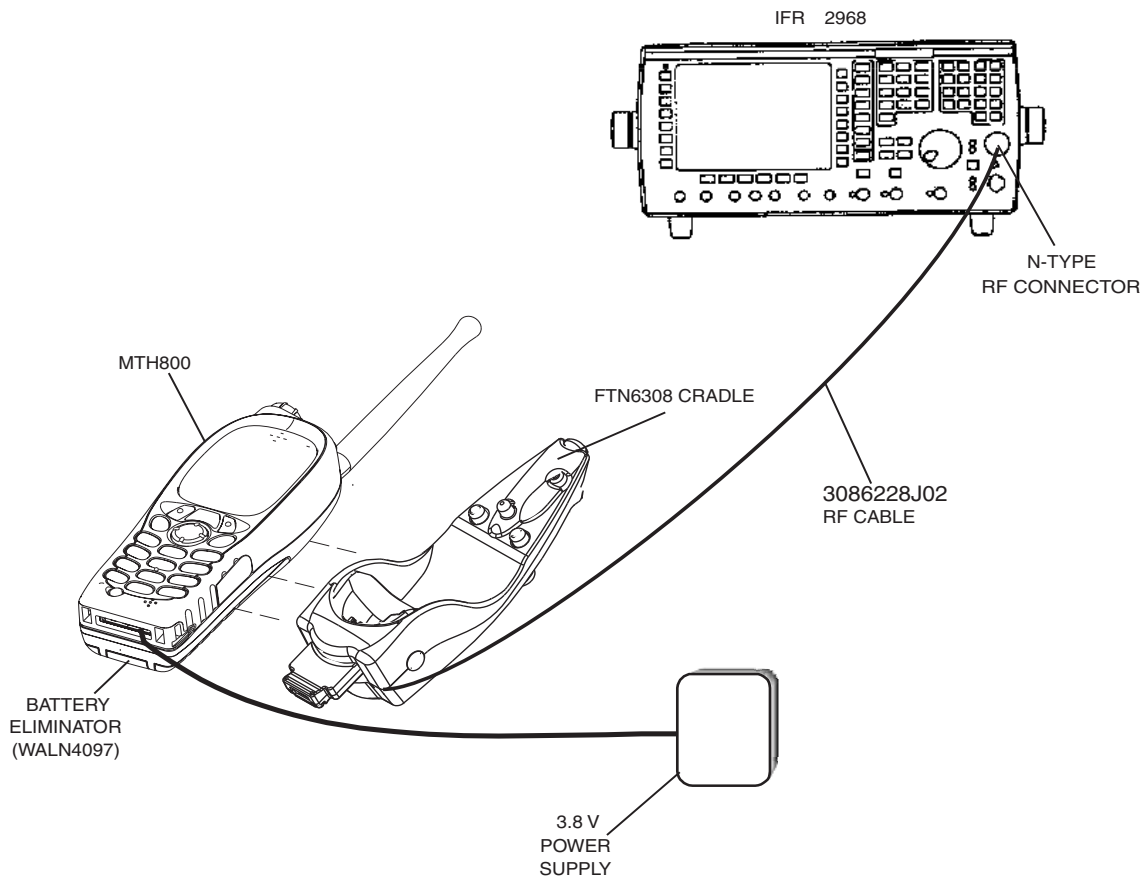

Figure 1. Typical Test Setup

Alternative Test Setup

Cable adapter 2888482K04 enables connecting to the vehicle adapter connector on a stand-alone main board. Thus, it allows testing of the main board in a disassembled unit. One side, the cable adapter has a mating vehicle adapter connector with mechanical grasping mechanism; on the other side the connection is SMA male.

Test Check List

The following table summarises the required test setups.

No.	Test Name	Test Setup	Terminal Setup	Test Conditions	Limits	
1.	Base Station Registration					
		Control Channel	460.0125 MHz	2400	TETRA 450MS	
		Traffic Channel	460.0125 MHz	2400	TETRA 450MS	
		Time Slot		3		
		Country Code		753		
		Network Code		2361		
		Base Color		1		
		Location Area		23		
		Min Rx Level				-110dBm
		Max Tx Level				30dBm
		Access Parameter			-53dBm	
		Mobile Power	30dBm			
		Burst Type			Normal	
2.	Transmitter Burst Power					
		RF Gen Level Burst Power		-90dBm	28-32dBm	
		Timing Error				<=0.25 Symbols
		Vector Error				Max 10% RMS, 30% Peak
		Frequency Error				-/+ 100Hz
3.	Call Processing Talk Back					

No.	Test Name	Test Setup	Terminal Setup	Test Conditions	Limits
		1KHz Test Signal Group Mode		-50dBm	
4.	Call Processing Call to Mobile				
		Private	4 digit random number & "Send"		28-32dBm
		RF Gen Level Burst Power		-90dBm	28-32dBm
		Timing Error			<=0.25 Symbols
		Vector Error			Max 10% RMS, 30% Peak
		Frequency Error			-/+ 100Hz

Transmitter Tests

1. Power Burst (Control Range)
2. Power Profiles
3. Tx Burst Timing Error
4. Vector Error RMS and Peak
5. Tx Frequency Error

Call Processing Tests

1. Talk Back
2. Call to Mobile

Duplex Test

Digital Duplex Test (Tx)

Measurement Capabilities:

Bar charts (Tx Power, Freq. Err, Vector Rms.), Spectrum Analyser, Power Analyser, Vector Analyser, Vector Diagrams

How to Configure the IFR 2968 Setup

Perform the following steps to configure the IFR 2968 with the terminal set:

1. Turn ON the IFR.
2. Press "Systems" Mode Key (wait until the digital system is initialised).
3. Press the "Tetra Mobile" softkey.
4. Press the "Setup" softkey and enter the System Parameters Screen.
5. Press the "Channel Plan" softkey.
6. Press the "More" key.
7. Press "Tetra 450MS" softkey. The "Control Channel" automatically changes to "2400"; and "Traffic Channel" automatically changes to 2500. Press twice the "Traffic Channel" softkey and check that the marker goes to Timeslot. Press Data key "3" followed by the "Traffic Channel" softkey, to change to Timeslot "3".
8. Press "Country Code" softkey. Enter "753" and "Country Code" softkey.
9. Press "Network Code" softkey. Thereafter, enter "2361" and press "Network Code" softkey.
10. Press "Base Color" softkey. Thereafter, enter "1" and press "Base Color" softkey.
11. Press "Location Area" softkey. Thereafter, enter "23" and press "Location Area" softkey.
12. Press "More" softkey.
13. Press "Min Rx Level" softkey. Thereafter, enter "-110dBm".
14. Press "Max Tx Level" softkey. Thereafter, enter "30dBm".
15. Press "Access Parameter" softkey. Thereafter, enter "-53dBm".
16. Press "Base Service" softkey.

Note: You are entering base services setup.

If the displayed values are different, please change the IFR setting to be similar to the values below.

Power On Registration: required

Power Off Deregistration: required

Priority Cell: yes

Minimum Mode Service: never used

Migration: not supported

System Wide Services: normal mode

17. Press "More" softkey.

TETRA Voice Service: supported

Circuit Mode Data Service: not supported

(Reserved): not available

SNDCD Service: not available

Air Interface Encryption: not available

Advanced Link: not supported

18. Press the "Return" softkey.

19. Press the "Neighbor Cell" softkey.

20. Verify that the following NEIGHBOUR CELL INFO values are displayed:

Note: If the displayed values are different, please change the IFR setting to be similar to the values below.

NEIGHBOUR CELL BROADCAST: SUPPORTED

BROADCAST INTERVAL: 10s

NEIGHBOUR CELL CHANNEL: 0000

NEIGHBOUR CELL LOCATION AREA: 00001

NEIGHBOUR CELL IDENTIFIER: 01

SLOW RE-SELECT THRESHOLD: 10dB

PRESS "MORE" softkey

SLOW RE-SELECT HYSTERESIS: 10dB

FAST RE-SELECT THRESHOLD: 10dB

FAST RE-SELECT HYSTERESIS: 10dB

21. Press the "Return" softkey.

22. Press the "Trunk Type" softkey and "Tx Trunked" softkey (Transmission).

23. Press "More" Softkey.

Note:

The displayed values are factory defaults and should not be changed.

It is not required to configure "Call Types" "Call Times" and "Messages".

24. Press "More" Softkey.

How to Configure the IFR 2968 Manual Test Screen

1. To enter "Manual test" screen, press "Manual" softkey.
2. Press "Control Channel" softkey. Thereafter, "2400" and press "Control Channel" softkey (IFR 2400 = Rx 460.0125MHz).
3. Press "Traffic Channel" softkey. Enter "2400" and press "Traffic Channel" softkey. The marker goes to Timeslot. Enter "3" and press "Traffic Channel" softkey. (Note that the Traffic Channel number changes automatically after entering the Control Channel number)
4. Press "RF Gen Level" softkey. Thereafter, enter "-50" and press "dBm" data keys.
5. Press "Mobile Power" softkey, press "+5dB step" or "-5dB step" softkey to reach 30 dBm/1W. Make sure the "Mobile Power" either in "expected level" or "close loop".
6. Press "return". Press "Burst Type" softkey and "Normal" softkey.
7. This completes the test equipment configuration setup.

Note: The System Setup Configuration Data is saved even after the power is turned off. However, the Manual Test Setup is not saved.

RF Tests

Receiver Tests

Simulate Base Station (Registration)

NOTE: This test requires programming the terminal. Refer to 6802974C10 TETRA Customer Programming Software (CPS) for MTH800.

1. Via the Depot version CPS, enable the Test Page field in the terminal codeplug and program the terminal.
2. Turn the terminal ON.
3. Check that registration and "GSSI:xxxxxx selected" is displayed on the IFR "Manual Test" screen.

RSSI Test

Before carrying out the following steps, record the Insertion loss (dB) of the cable loss value - (X) dB. Also, 0.5 dB, the maximum insertion loss of the Antenna assembly adapter should be added to the total calculated insertion loss.

1. In the IFR Manual Test Mode, press the "RF Gen Level" softkey and enter "-80dBm".
2. Before testing, the terminal should be configured to RSSI mode using the following sequence. When performing steps 3 thru 6, make sure that you press the handset keys sequentially (less than a second between every consecutive press).
3. Press the "Star" Key.
4. Press the "#" Key.
5. Press the "Menu" Key.
6. Press the "Right Arrow" Key.
7. Scroll to "Cells Info".
8. Press the "Select" softkey.
9. Press the "Right Arrow" Key.
10. Press the "Trace" softkey.

Note: RSSI results will flash on the screen every few seconds.

The display shows: SERV: xx

RSSI: -81

SQE: xx

Disregard the "SERV" and "SQE" results.

The actual measured result should be:

{-80dBm (IFR RF Gen Level) -0.5dB(adapter)-XdB (cable)} +/-1 dB.

RSSI = {Radio RSSI Result – [Antenna assembly Adapter (dB) + Insertion loss of the Cable (dB)]}.

To stop the "Trace" process, perform the following. When performing steps 11 thru 15, make sure that you press the handset keys sequentially (less than a second between every consecutive press):

11. Press the "Star" Key.
12. Press the "#" Key.
13. Press the "Menu" Key.
14. Press the "Right Arrow" Key.
15. Scroll to "Cells Info"
16. Press the "Select" softkey.
17. Press the "Stop" softkey.
18. Press twice the "Back" softkey.

Transmitter Tests

1. Verify that your terminal is in "Group Mode".
2. Press the "RF Gen Level" softkey. Enter "-90dBm" by pressing the data keys and "RF Gen Level" Key.
3. Press the "PTT" of the terminal and monitor the IFR "Manual Test" screen which displays the Burst Power, Power Profile, Timing Error, Vector Error, and Frequency Error.

Note: You have to hold the PTT in the pressed position long enough to enable you to read the results.

- Burst Power Required Results: 28-32dbm.
- Power Profile: Passed.
- Timing Error: ≤ 0.25 symbols.

- Vector Error: Max 10% RMS, Max 30% Peak.
 - Max 5% residual.
 - Frequency Error: -/+ 100Hz.
4. Press the "Clear Down" softkey, to proceed with other tests.

Call Processing Test

Talk Back

Before you start this test, make sure that handset and test equipment are configured the same as given in the Transmitter Test.

1. Press and hold the "PTT" then press "talk back" softkey and speak into the mic of the terminal. Release the "PTT" and you will hear your speech.
2. Press the "silence" softkey to stop the speech.
3. Press and hold the "PTT" then press the "Test Sound" softkey to provide the 1kHz signal to the terminal speaker.
4. Release the "PTT", you will hear a 1kHz tone from the terminal speaker continuously.
5. Press the "Silence" softkey to mute the 1kHz Audio Signal of the speaker.
6. Press the "Clear Down" softkey and check that the "Cleardown Complete" status appear on the IFR "Manual Test" screen.

Call to Mobile

1. Press the "Call Mobile" softkey on the IFR.

Note: Select type of call.

2. Press "Private Call" softkey to select Private Call.

Note: You will hear beeps from the handset speaker.

3. Press "Abort Call" softkey. Duplex Test (Phone/Privet Mode)

Note: Repeat step 1 through 3 for "Phone Call" and "Emergency Call".

Digital Duplex Test (Tx)

1. Perform the following test in "Phone" or "Private" mode.
2. Dial a random number "9359" using the Alphanumeric keys of the terminal and press the "Send" Key.

The following results are displayed on the IFR "Manual Test" Screen.

- Burst Power Required Results: 28-32dbm
- Power Profile: Passed
- Timing Error: <0.25 Symbols.
- Vector Error: Max 10% RMS, Max 30% Peak.
- Max 5% residual.
- Frequency Error: -/+ 100Hz

3. Press the "talk back" softkey. Place the internal earpiece close to your ear. Speak into the handset microphone and hear your speech (after a short delay) from the handset internal earpiece.

Note: If you need more details, press the "Duplex Test" mode key.

4. Press the "duplex test (Tx)" softkey.

The "Digital Duplex test" results will be displayed on the IFR screen providing you with the following bar charts measurement capabilities:

- Power
- Vector RMS
- Frequency Error

For Power Analyser Graph:

5. Press "power ana" softkey.
6. Check that the power frame falls within the limits.

For Spectrum Analyser Graph:

7. Press "Spec ana" softkey.
8. Monitor the Tx frequency.

For Vector Analyser Diagram:

9. Press the "Vec Anal" softkey
10. Monitor the constellation diagram.

11. Press the "Vector Diagram" softkey.
12. Press the "Rotated vector" to zoom in on the constellation.
13. Press the handset "End" key.

Manual Mode Testing

Preparation for Testing

1. Verify that the terminal is turned off.
2. Press the "4", "5" and "6" keys together and then, press the On/Off key to turn the terminal on.
3. The display shows "LCD Color test Press Any Key To Proceed".

Tests

1. Press any key consecutively. The display shows horizontal red lines that becomes thicker with every key press, until it becomes fully red.
2. Press any key again, the display shows four colored rectangles.
3. Press any key consecutively. The display shows vertical green lines that becomes thicker with every key press, until it becomes fully green.
4. Press any key again. The display becomes fully blue and the message "END LCD test !!!" appears.
5. Press any key again. The display shows "Battery Interface Test".
6. Press any key again. The display shows "Battery Interface Test PASS".
7. Press any key again. The display shows "Vibrator On", verify that the terminal is vibrating.
8. Press any key again. The display shows "Red Led on" and the Red LED at the top of the terminal is lit.
9. Press any key again. The display shows "Green Led on" and the Green LED at the top of the terminal is lit.
10. Press any key. The display shows "Both Leds on" and the LED located on the top of the terminal is blinking in amber (combination of red and green lights of the two halves of the LED).
11. Press any key again. The display shows "Keypad Backlight On" and the keypad backlight is On.

12. Press any key again. The display shows "Display Backlight On" and the display backlight is On.

Note: The following readings appears only when a Universal Crypto Module (UCM) board is installed in the unit.

13. Press any key again. The display shows "UCM Detected".
14. Press any key again. The display shows "UCM Power up Success".
15. Press any key again. The display shows "UCM Wake Up Success".
16. Press any key again. The display shows "UCM Ping Success".

Note: The following reading appears only when a UCM board is not installed in the unit.

17. Press any key again. The display shows "UCM Not Detected".
18. Press any key again. The display shows "Speaker Tone Test", a tone is heard via the speaker.
19. Press any key again. The display shows "Internal Earpiece Tone Test", a tone is heard via the internal earpiece.
20. Press any key again. The display shows "Connect PHF for the following Tests". Insert a headset into the PHF connector and plug the PHF earpiece into your ear.
21. Press any key again. The display shows "PHF Earpiece Tone Test". A tone is heard via the PHF earpiece.
22. Press any key again. The display shows "Connect RSM-CE for the following Tests". Connect the RSM to the CE connector.
23. Press any key again. The display shows "RSM-CE Connector Tone Test". A tone is heard via the RSM speaker.
24. Press any key again. The display shows "INT MIC to INT EAR Loopback Test". Place the internal earpiece close to your ear. Speak into the internal MIC, and you will hear your voice via the internal earpiece.
25. Press any key again. The display shows "Connect PHF for the following Tests". Insert a headset into the PHF connector and plug the PHF earpiece into your ear.
26. Press any key again. The display shows "TOP Mic to PHF EAR Loopback Test". Speak into the top microphone, and you will hear your voice via the PHF earpiece.
27. Press any key again. The display shows "PHF Mic to PHF EAR Loopback Test". Speak into the PHF microphone, and you will hear your voice via the PHF earpiece.
28. Press any key again. The display shows "Connect RSM-CE for the following Tests". Connect the RSM to the CE connector.

29. Press any key again. The display shows "RSM-CE connector MIC to INT EARP Loopback Test". Place the internal earpiece close to your ear. Speak into the RSM mic, and you will hear your voice via the internal earpiece.
30. Press any key again. The display shows "Connect PHF for the following Tests". Insert a headset into the PHF connector and plug the PHF earpiece into your ear.
31. Press any key again. The display shows "Chopper-Noise Test INT MIC to PHF EAR". Listen for chopper noise via the PHF earpiece. Make sure chopper noise is not audible.
32. Press any key again. The display shows "Chopper-Noise Test TOP MIC to PHF EAR". Listen for chopper noise via the PHF earpiece. Make sure chopper noise is not audible.
33. Press any key again. The display shows "Chopper-Noise Test PHF MIC to PHF EAR". Listen for chopper noise via the PHF earpiece. Make sure chopper noise is not audible.
34. Press any key again. The display shows "Connect RSM-CE for the following Tests". Connect the RSM to the CE connector.
35. Press any key again. The display shows "Chopper-Noise Test RSM-CE connector MIC to INT EAR". Place the internal earpiece close to your ear and listen for chopper noise from the internal earpiece. Make sure chopper noise is not audible.
36. Press any key again. The display shows "Chopper-Noise TOP MIC to RSM-CE connector SPKR". Place the RSM speaker close to your ear and listen for chopper noise. Make sure chopper noise is not audible.
37. Press any key again. The display shows all the terminal keys.
38. Press every key, one by one. Each key you press causes its respective display to disappear.
39. Press any key to continue.
40. Press the  (navigator) key. Every time you press causes the respective display to disappear.
41. After pressing all keys, the display is clear.
42. Press any key to continue. The display shows "Rotary test". Turn the rotary switch clockwise. Each click causes the respective clockwise arrow sign to disappear. Then, a set of counter clockwise arrows appear. Turn the rotary switch counter clockwise. Each click causes the respective counter clockwise arrow sign to disappear. The display shows "Press the rotary".
43. Press the rotary.
44. This completes the test. Press any key to turn the terminal OFF.

Charger Recognition Test

- Turn the terminal ON.
- Connect the Rapid Travel Charger accessory connector to the handset. Check whether the LCD display shows “charger connected” and that the keypad back-light is turned ON.
- Connect the Vehicle Power Adapter (VPA) Charger accessory connector to the handset. Check whether the LCD display shows “charger connected” and that the keypad back-light is turned ON.
- Connect the handset to the Desktop Charger. Check whether the LCD display shows “charger connected” and that the keypad back-light is turned ON.
- Place the handset in the Digital Car Kit cradle. Verify that the car ignition switch is turned ON. Check whether the LCD display shows “Car Kit connected”, and that the keypad back-light is turned ON.
- Verify that the battery charger is in progress (the process advance is indicated on the Battery Strength icon).

Press the “ON/OFF” key. The terminal should turn OFF.

Service Flowchart

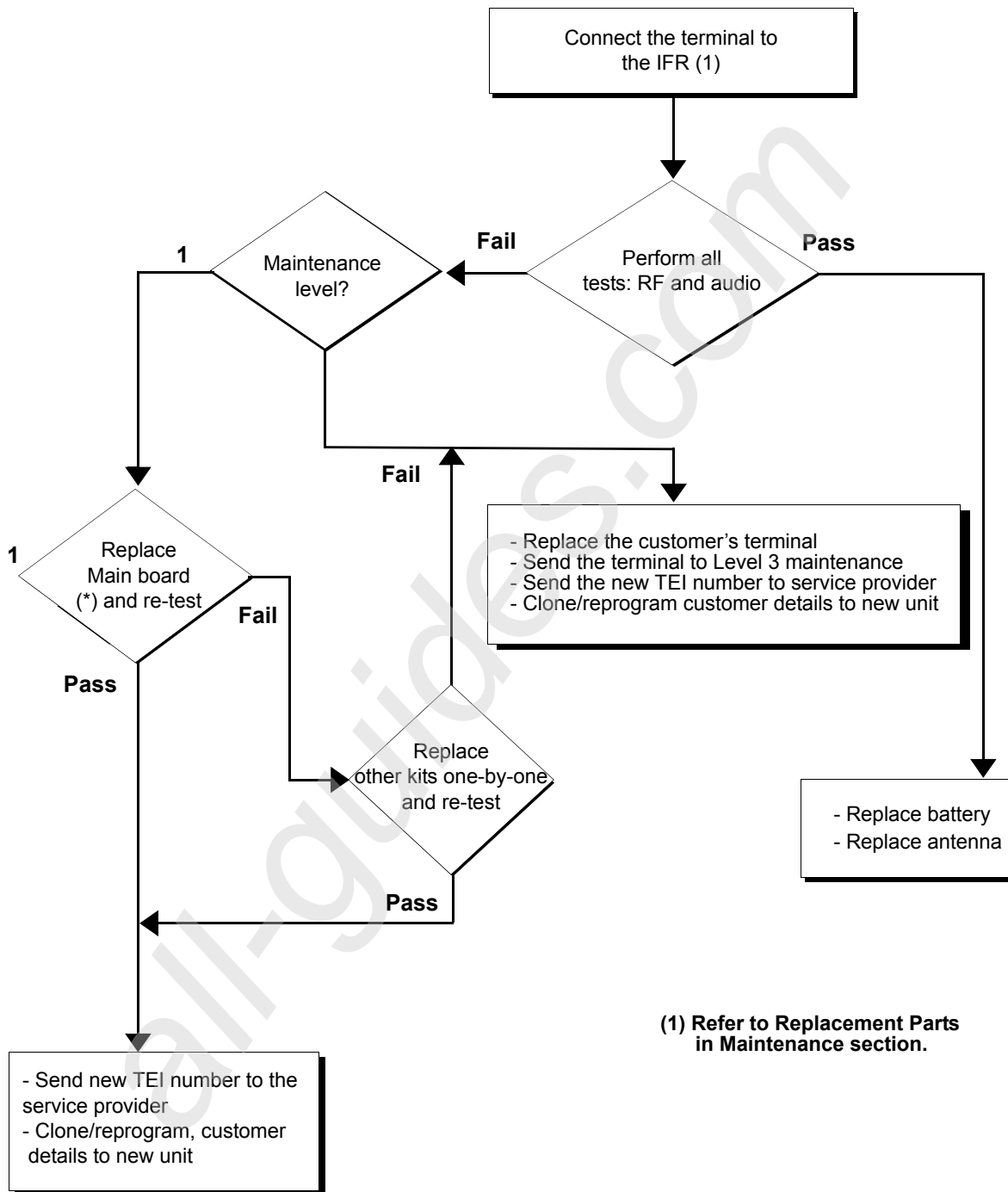

(1) Refer to Replacement Parts in Maintenance section.

(*) Main Board: See Service Replacement Kit (Appendix A)
Note: Not field replaceable for Latin America

CHAPTER 5

PROGRAMMING THE TERMINAL

NOTE: For programming the terminal, refer to 6802974C10 TETRA Customer Programming Software (CPS) for MTH800.

Notes

CHAPTER 6

MAINTENANCE

Preventive Maintenance

This TETRA Handportable Terminal does not require a scheduled preventive maintenance program. However, periodic visual inspection is recommended.

Inspection

Inspect the terminal's external surfaces. A detailed inspection of interior circuitry is not needed or recommended.

Cleaning

The following procedures describe the recommended cleaning agents and methods to be used when cleaning the external and internal surfaces of the radio. External surfaces should be cleaned whenever a periodic visual inspection reveals the presence of smudges, compound, or grime. Internal surfaces (circuit boards and components) should be cleaned only when the radio is disassembled for servicing or repair.

The only recommended agent for cleaning external radio surfaces is a 0.5% solution (one teaspoon of detergent per gallon of water) of mild dishwashing detergent in water. The internal surfaces should be cleaned only with isopropyl alcohol (100% by volume).

NOTE: Internal surfaces should be cleaned only when the radio is disassembled for service or repair.

Take care to clean the bottom connector frequently and particularly prior to the programming procedure e.g. with a soft brush (do not use fluids).



Caution

The effects of certain chemicals and their vapors can have harmful results on certain plastics. Avoid using aerosol sprays, tuner cleaners, and other chemicals.

Cleaning External Plastic Surfaces

Apply the 0.5% detergent-water solution sparingly with a stiff, non-metallic, short-bristled brush to work all loose dirt away from the radio. Use a soft, absorbent, lintless cloth or tissue to remove the solution and dry the radio. Make sure that no water remains entrapped near the connectors, cracks, or crevices.

Cleaning Internal Circuit Boards and Components

Isopropyl alcohol (100%) may be applied with a stiff, non-metallic, short-bristled brush to dislodge embedded or caked materials located in hard-to-reach areas. The brush stroke should direct the dislodged material out and away from the inside of the radio. Make sure that controls or tunable components are not soaked with alcohol. Do not use high-pressure air to hasten the drying process since this could cause the liquid to collect in unwanted places. After completing of the cleaning process, use a soft, absorbent, lintless cloth to dry the area. Do not brush or apply any isopropyl alcohol to the frame, front cover, or back cover.

NOTE: Always use a fresh supply of alcohol and a clean container to prevent contamination by dissolved material (from previous usage).

Safe Handling of CMOS Devices

Complementary metal-oxide semiconductor (CMOS) devices are used in the terminal. While the attributes of CMOS devices are many, their characteristics make them susceptible to damage by electrostatic or high voltage charges. Damage can be latent, resulting in failure occurring weeks or months later. Therefore, special precautions must be taken to prevent device damage during disassembly, troubleshooting, and repair. The following handling precautions are mandatory for CMOS circuits, and are especially important in low humidity conditions.

- All CMOS devices must be stored or transported in conductive material so that all exposed leads are shorted together. CMOS devices must not be inserted into conventional plastic "snow" or plastic trays of the type that are used for storage or transportation of other semiconductor devices.
- All CMOS devices must be placed on a grounded bench surface and the technician must also be grounded before handling the devices. This is done most effectively by having the technician wear a conductive wrist strap in series with a 100kW resistor to ground.
- Do not wear nylon clothing while handling CMOS circuits.
- Do not insert or remove CMOS devices with power applied. Check all power supplies to be used for testing CMOS devices and be certain there are no voltage transients present.
- When straightening CMOS device leads, provide ground straps for the apparatus used.
- When soldering, use a grounded soldering iron.
- All power must be turned off in a system before printed circuit boards containing CMOS devices are inserted, removed, or soldered.

Pre-baking of Integrated Circuits

Electronic components are generally coated with plastic material which has the nature of not being waterproof. If kept unsealed, the components can absorb humidity. When soldered to the board (especially with reflow techniques), the sudden change in temperature can cause fissure or crack which can result in malfunction or damage.

To avoid this problem, these moisture sensitive components (MS) should be stored and shipped in a sealed wrapping (dry pack). Processing is not required only with "dry components" when an uninterrupted dry storage can be guaranteed, otherwise the components have to be pre-baked.

If a reflow procedure takes place close to MS components, the whole board must be pre-baked.

Refer to the table below.

P/N	MSL	DESCRIPTION
5104932K08	3	Tomahawk
5186988J77	3	Javelin
5108683Y54 or equivalent	3	TETRA PA, U901
5116650H01	3	GCAP3 2.4
5166541A01	3	Patriot ROM3
5115443H01	3	LNA-Life
5187512V01	3	Half-Life
5185941F11	3	PSRAM
5185956E43	3	FLASH 16M
5189378V12	3	EEPROM
5188450M52	3	SiRF GPS IC

Baking Precautions for TETRA Power Amplifiers (PAs)

PAs in an open reel after baking should be used within 168 hours. After 168 hours the PAs must not be used until baked again. Because this is quite a short time, use at least two reels for each build: one on the machine, and the other still in baking. After 168 hours the reel on the machine should be replaced with the freshly baked reel. It is recommended to order a sufficient reserve of PAs, so that at least two reels will be available in each build.

In addition, please note the following very important precautions that must be observed when baking TETRA PAs before builds:

- Correct baking (needed only if the reel has been opened) procedure is at minimum
8 HOURS IN 125 DEGREES.
- It is **ABSOLUTELY FORBIDDEN** to bake at temperature above 125 degrees.
- Please note also that reels that have not been opened (still in vacuum) do not need baking.
- When this part is replaced manually, it should be pressed to the PCB during the soldering.

Level 1 and Level 2 Maintenance

This manual covers Level 1 and Level 2 Maintenance: at Level 1 maintenance you replace the terminal and/or accessories and send the faulty unified chassis and/or accessories to a higher level of maintenance; at level 2 maintenance a faulty kit is replaced. For Level 3 please refer to Appendix A.



Environmentally Preferred Products (EPP), refer to the indications on the printed circuitboards, are developed and assembled using environmentally preferred components and solder assembly techniques in compliance to the European Union's **Restriction of Hazardous Substances (ROHS) Directive 2002/95/EC** and **Waste Electrical and Electronic Equipment (WEEE) Directive 2002/96/EC**. To maintain product compliance and reliability, use only the Motorola specified parts in this manual.

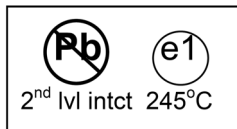

For the identification of lead (Pb) free assemblies, all EPP products will carry the EPP Marking with the symbol shown below on the PCB. The marking provides information to those performing assembly, servicing and recycling operation on these product adhering to the JEDEC standard #97. The EPP Marking will be in the form of label or marking on printed circuit board (PCB).

Disassembling and Reassembling the MTH800 Unit

Mechanical checks and self tests should be performed on the unit at the basic level of service. To perform testing at the field level, it is sometimes necessary to remove the antenna and the housing from the unit. Procedures for disassembling and reassembling the unit are described in the sections that follow.

Note: Read each procedure thoroughly before performing the actual task.

Protecting Static-Sensitive Devices

This unit contains static-sensitive devices that must be protected when opening the unit, or storing and transporting any printed-circuit board.

To create a proper ground

- Ground the working surface of your service bench. If possible, use the Motorola Static Protection Assembly (part #0180386A82) to ground your service bench. This assembly contains a wrist strap, two ground cords, a table mat, and a floor mat.
- Wear a conductive wrist strap in series with a 1Mg ohm resistor to ground.
- Do not wear nylon clothing when handling any printed-circuit board.
- Prior to touching any printed-circuit board, touch an electrical ground to remove any static charge that might have accumulated.

To store or transport a circuit board

- Place the printed-circuit board in conductive, anti-static material.
- Do not insert the printed-circuit board into conventional plastic "snow" trays used for transporting other devices.

Removing and Installing the Antenna

Note: The antenna must be removed each time the back housing is removed.

Recommended tools: no tools are required.

To remove the antenna from the unit

(See Figure 1)

Unscrew the antenna counter clockwise until it is detached from the handset.

To install the antenna in the unit

Screw the antenna clockwise to the handset.

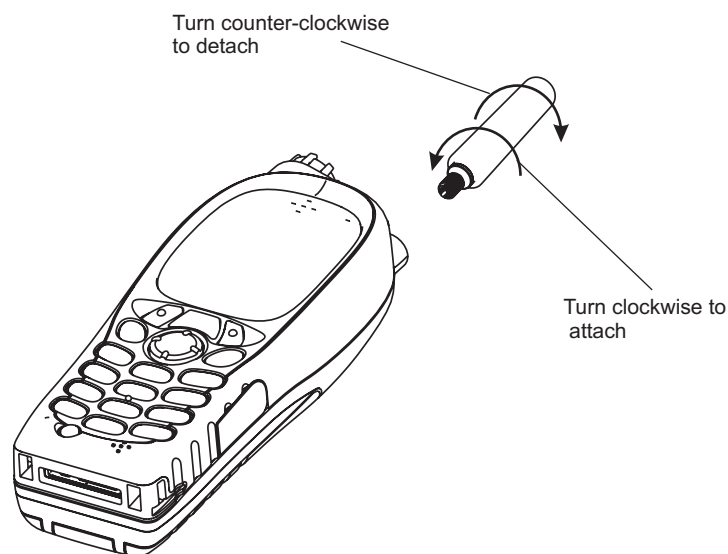

Figure 1 Antenna Removal and Installation

Removing and Installing Battery Door and Battery

Recommended tools: no tools are required

To remove the battery door from the unit

(See Figure 2 / Figure 4)

1. Place the unit facing down on the work area.
2. Press the battery door release button, slide the door towards the bottom of the unit and lift it up from the unit.

To remove the battery

(See Figure 3 / Figure 5)

1. Press the battery fastening bridge toward the upper side of the unit.
2. Simultaneously, using other hand, release the battery from its chamber.

To install the battery

1. Locate the battery so that the upper part (thin part) is inserted underneath the fastening bridge.
2. Carefully press the battery lower part (coloured silver) down until it snaps into location.

To install the battery door

1. Position the door on the unit over the battery so that the door release button is just above the battery fastening bridge.
2. Slide the door upward until the door snaps into location.
3. Verify that the door is aligned with the handset back housing.

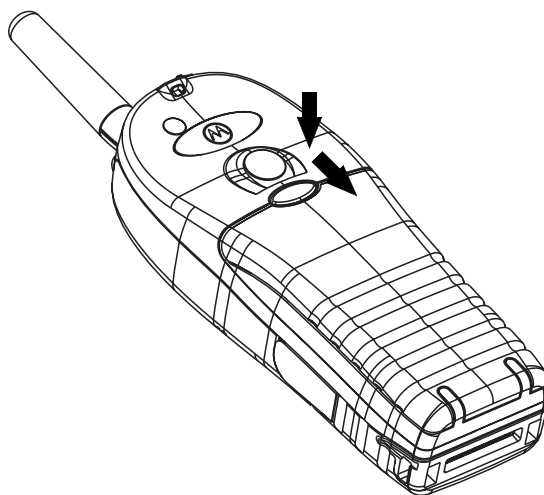

Figure 2 Thin Battery Door Removal and Installation

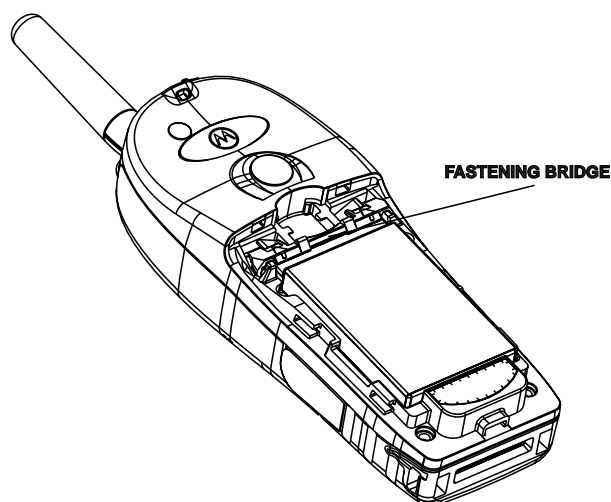

Figure 3 Thin Battery Removal and Installation

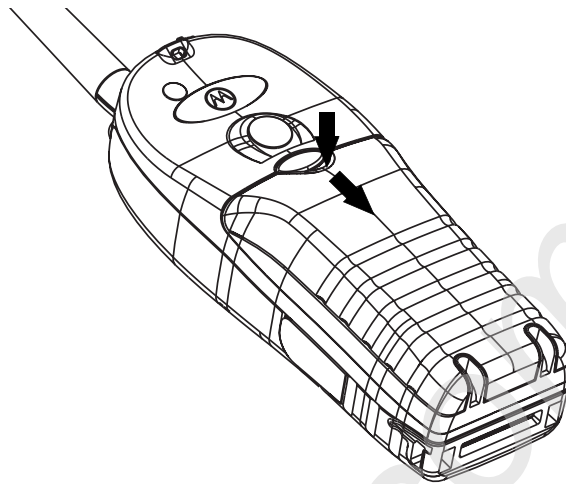

Figure 4 Thick Battery Door Removal and Installation

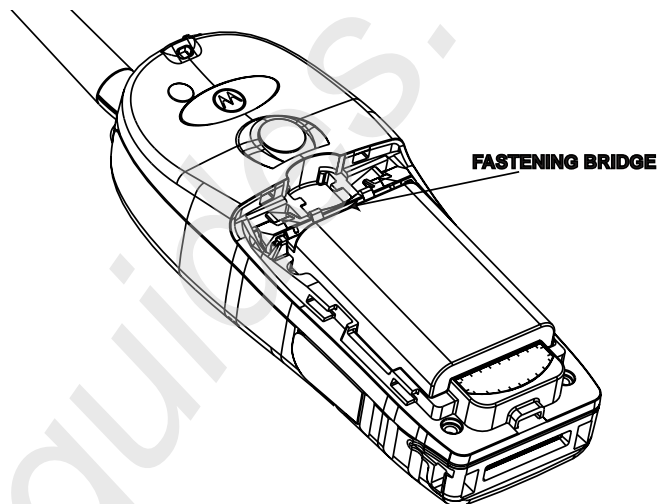

Figure 5 Thick Battery Removal and Installation

Removing and Installing the Audio Assembly Cap

Recommended tools: no tools are required

To remove the audio assembly cap from the unit

Pull the cap away from the audio assembly.

To install the audio assembly cap onto the unit

(See Figure 6)

1. Slide the tooth-shaped tip into location.
2. Snap the tip into location.

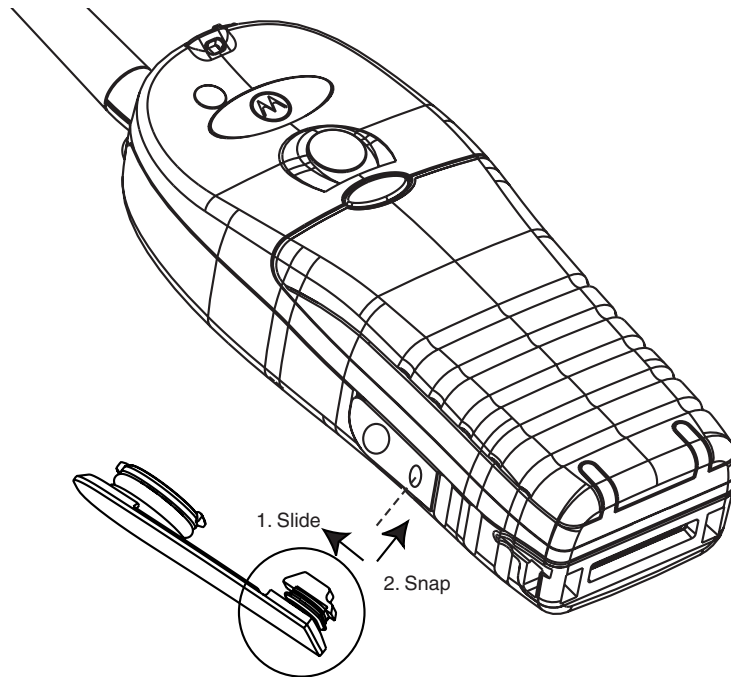

Figure 6 Audio Assembly Cap Removal and Installation

Removing and Installing the Back Housing

Recommended tools: T-8 Torx bit, Torx driver, mini flat-tip screwdriver

To remove the back housing from the unit

(See Figure 7)

1. Remove the antenna.
2. Remove the battery door and the battery.
3. Place the unit facing down on the clean work area.
4. Using the screwdriver remove the oval label at the top of the unit (Logo label) and the Tamper Evident label to gain access to all six screws fastening the back housing. Clean the adhesive remains of the labels using alcohol.
5. Using the Torx driver with the T-8 Torx bit, unscrew the six screws fastening the back housing. Remove the six washers.
6. Carefully remove the back housing from the unit.

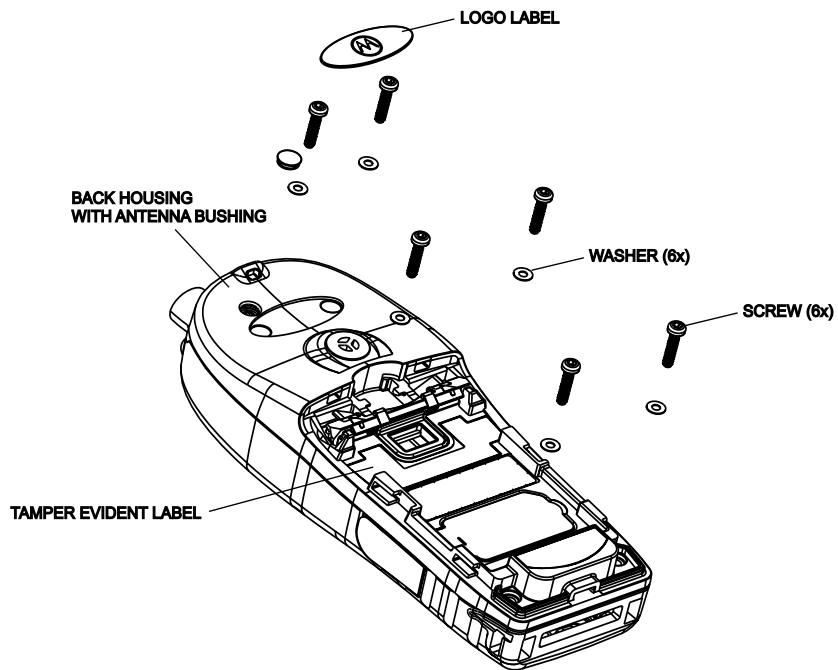

Figure 7 Back Housing Removal and Installation

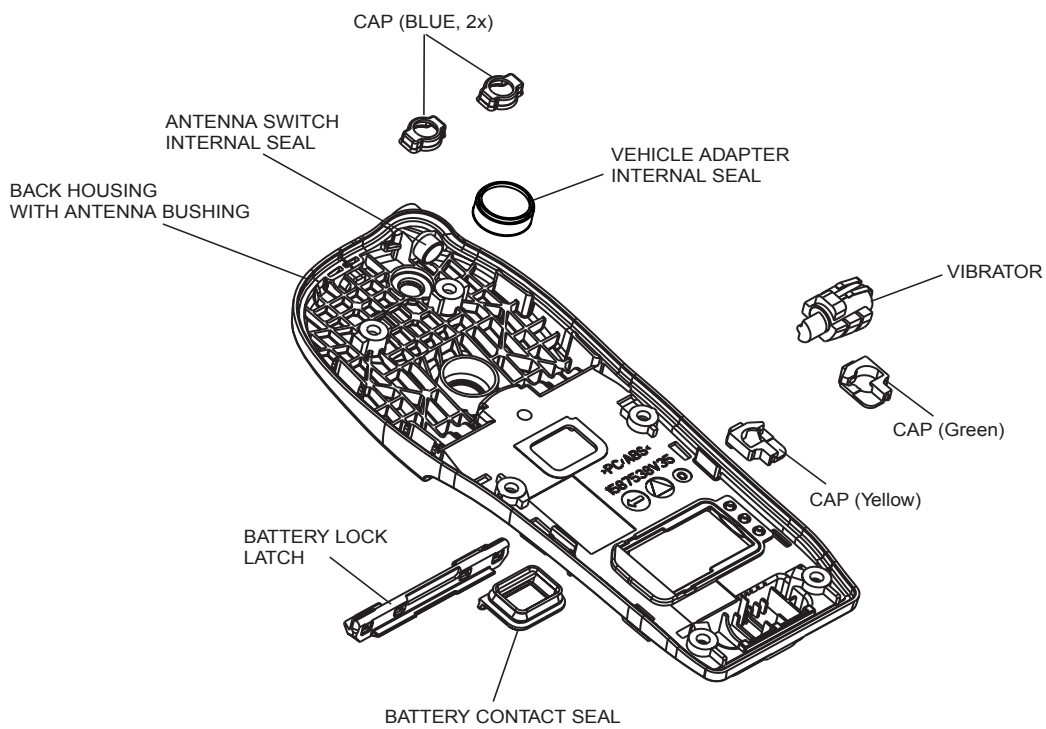

Figure 8 Back Housing

To install the back housing

1. Position the back housing over the unit.
2. Verify that the cover is positioned correctly, screw holes are aligned to the threads of the front housing, external antenna connector is inserted into its dedicated hole, and the styling groove of the back housing meets the styling groove of the front housing.
3. Using the Torx driver with the T-8 Torx bit, screw with a torque of 3.8 ± 0.3 in-lb (0.43 ± 0.034 Nm).
4. Add the washers. Screw the back housing screws in the following order: bottom two screws first, and then diagonally.
5. Glue a new oval label over the holes of the two upper screws and a new Tamper Evident label on the holes of the two center screws.

Removing and Installing the Vibrator

Recommended tool: mini flat-tip screwdriver

(See Figure 8)

To remove the vibrator

1. Remove the back housing. Refer to "Removing and Installing the Back Housing" on page 9.
2. Turn the back housing up side down and, using the screwdriver, remove the vibrator from its chamber inside the back housing.

To install the vibrator

1. Carefully push the vibrator into its chamber in the back housing.
2. Install the back housing.

Removing and Installing the Main Board

Recommended tools: mini flat-tip screwdriver

To remove the main board from the unit

(See Figure 9)

1. Remove the back housing. Refer to “Removing and Installing the Back Housing” on page 9.
2. Disconnect the accessory flex cable from the main board.
3. Disconnect the main flex cable connector.
4. Gently lift the main board, and remove it from the unit.

**Caution**

When disassembling the main board from the chassis, place the screwdriver's flat tip as close as possible to the corner of the main board (side 1) as indicated in Figure 9.

Failing to do so might damage one of the components shown in the main board (side 2) details, and thus cause transmitter performance degradation.

To install the main board

1. Connect the main flex cable connector.
2. Verify that the accessory flex cable sticks out of the back housing. Position the main board in location. Verify that the two guide pins are inserted into the holes in the main board. Gently push the main board down and connect the accessory flex cable.
3. Install the back housing.



Caution

When disassembling the main board from the chassis, place the screwdriver's flat tip as close as possible to the corner of the main board (side 1). Failing to do so might damage one of the components shown in the main board (side 2) details, and thus cause transmitter performance degradation.

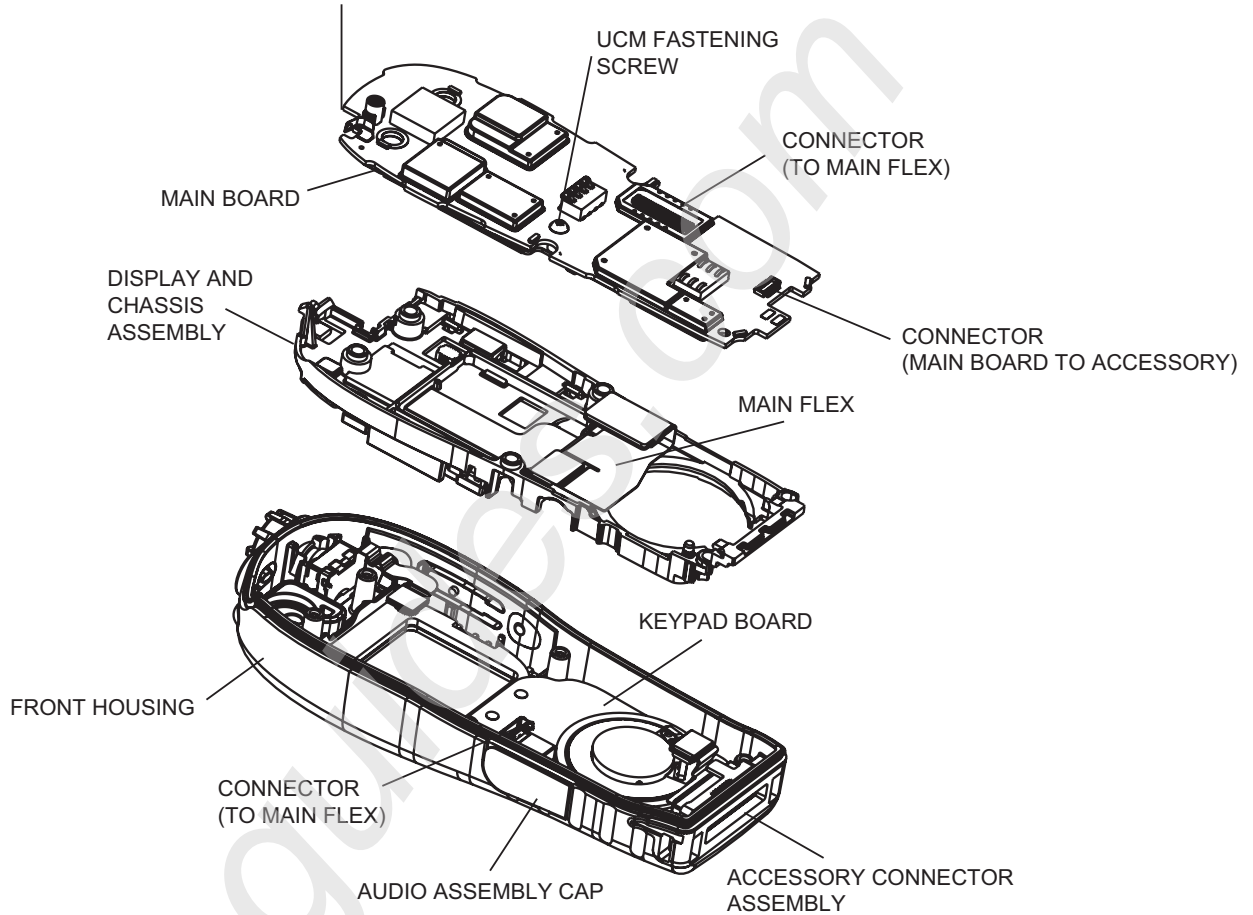

improper disassembling of the mainboard may damage these components



Removing and installing the UCM Board

Recommended tools: Phillips screwdriver

To remove the UCM board from the main board

(See Figure 9 and Figure 10)

1. Remove the main board from the display & chassis assembly. Refer to "Removing and Installing the Main Board" on page 11.
2. Open the UCM fastening screw.
Please note that the **UCM-M module** does not have a fastening screw.
3. Turn the Main Board over.
4. Gently remove the UCM Board from the Main Board. Verify not to damage the UCM connector when removing the board.

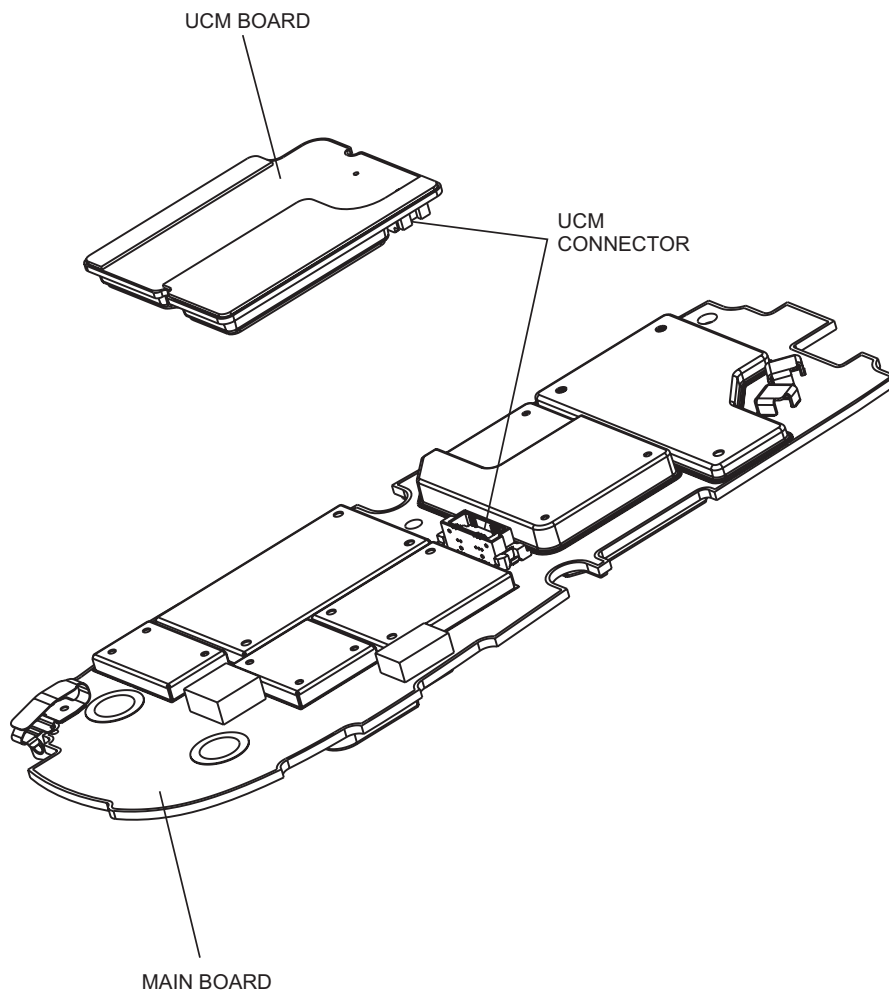

Figure 10 UCM Board Removal and Installation

To install the UCM board on the main board

1. Hold the Main Board with the UCM connector facing you.
2. Carefully attach the UCM Board to the Main Board. Verify the connector is connected correctly.
3. Turn the Main Board over.
4. Close the UCM fastening screw. Screw to 2.5 ± 0.3 in-lb (0.28 ± 0.034 Nm). Please note that the **UCM-M module** does not have a fastening screw.
5. Install the Main Board.

Removing and installing the Display

Recommended tools: mini flat-tip screwdriver

Note: *Do not* touch the display in the active viewing area; fingerprints on this surface cannot be easily removed.
When servicing the display, work in a clean cell using de-ionised air pressure.

To remove the display from the unit

(See Figure 11 and Figure 12)

1. Remove the main board from the display & chassis assembly. Refer to "Removing and Installing the Main Board" on page 11.
2. Remove the display & chassis assembly out from the unit.
3. Place the chassis assembly, with the display facing down, on the clean work area.
4. Insert the screwdriver into one of the side slots in the upper side of the chassis assembly, above the display board, and gently push the display holders out from the chassis assembly.
5. Turn the chassis around so the display is facing you.
6. Disconnect the display flex cable connector from the display board.
7. Carefully remove the display.

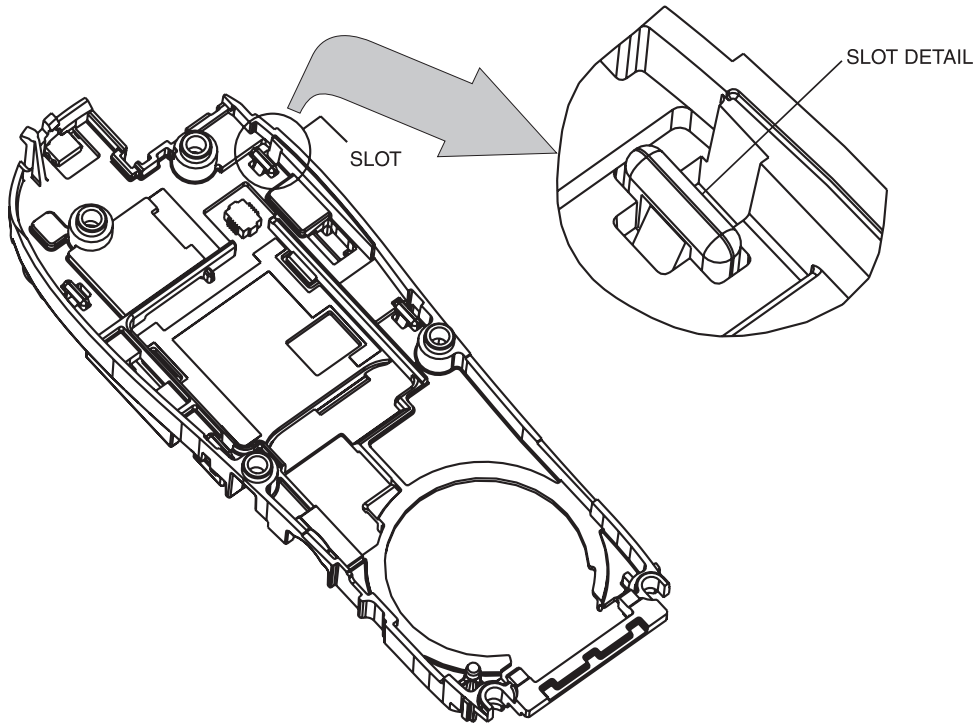

Figure 11 Display Removal - Holders Release

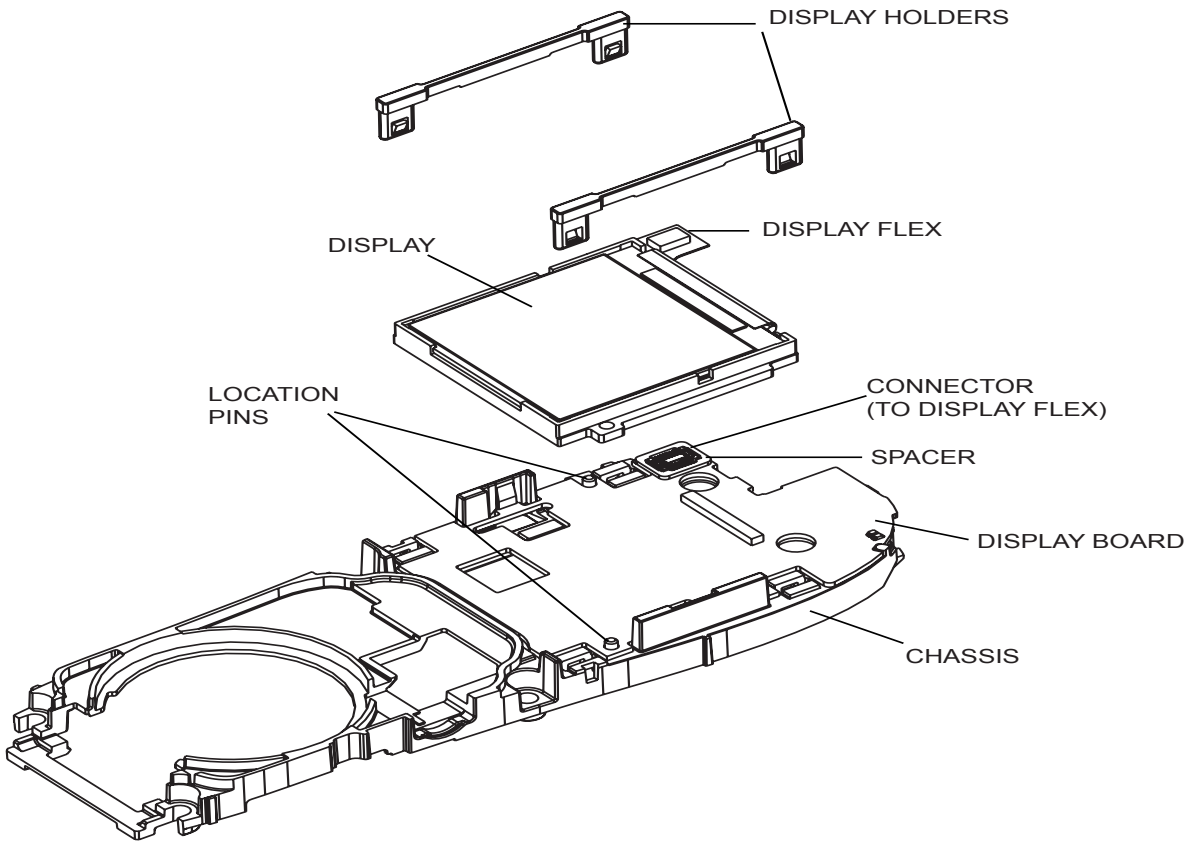

Figure 12 Display Assembly Removal

To install the display

1. Verify that no damage exists on the LCD glass. Install the protective film back in place.
2. Locate the display above the display board. Verify that the display is inserted into the 2 location pins.
3. Connect the display flex cable connector to the display board.
4. Carefully install the display holders, one after the other. Verify that the holders are securely snapped into the slot.
5. Remove the protective film from the LCD glass.
6. Install the main board.

Removing and Installing the Display Board

Recommended tools: mini flat-tip screwdriver

To remove the display board from the unit

(See Figure 13)

1. Remove the display from the display & chassis assembly. Refer to "Removing and installing the Display" on page 15.
2. Place the chassis assembly, with the display facing down, on the clean work area.
3. Disconnect the main flex cable connector.
4. Turn the chassis around so the display is facing you.
5. Insert the screwdriver into one of the side slots in the upper side of the chassis assembly, above the display board, and gently push the display board out from the chassis assembly.

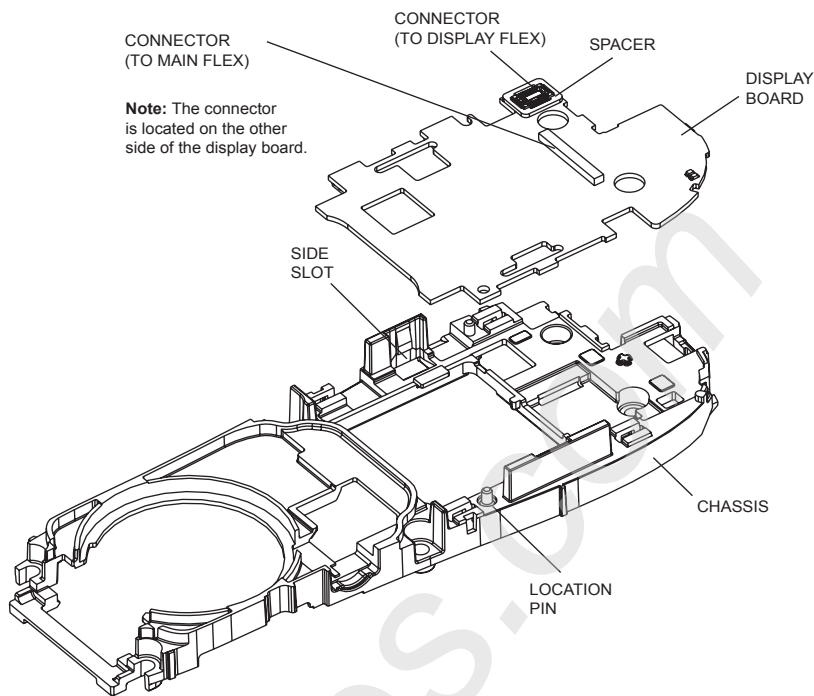



Figure 13 Display Board Removal Details

To install the display board

1. Before installing the display board into the chassis, place spacer (with adhesive turned down) on the display board connector. Then press on the spacer to glue it to the display board.
2. Insert the display board between the two snags at the sides of the chassis.
3. Gently push the display assembly board down until it snaps into location. Verify that the board is inserted into the right bottom location pin.
4. Turn the display & chassis assembly up side down.
5. Connect the main flex cable connector.
6. Install the display.

Removing and Installing the Accessory Connector Assembly

Recommended tools: mini flat-tip screwdriver

 <p>Caution</p>	<p>A <u>new</u> accessory connector (0187506V54) must be installed after removal.</p>
---	---

To remove the accessory connector

(See Figure 14)

1. Remove the display & chassis assembly. Refer to "Removing and installing the Display" on page 15.
2. Using the screw driver, lift the accessory connector retainer and remove the accessory connector.

To install the accessory connector

1. Install the accessory connector. The accessory flex should stick out from the housing's right side.
2. Locate the retainer above the accessory connector.
3. Gently push the retainer down onto the accessory connector.
4. Install the display & chassis assembly.

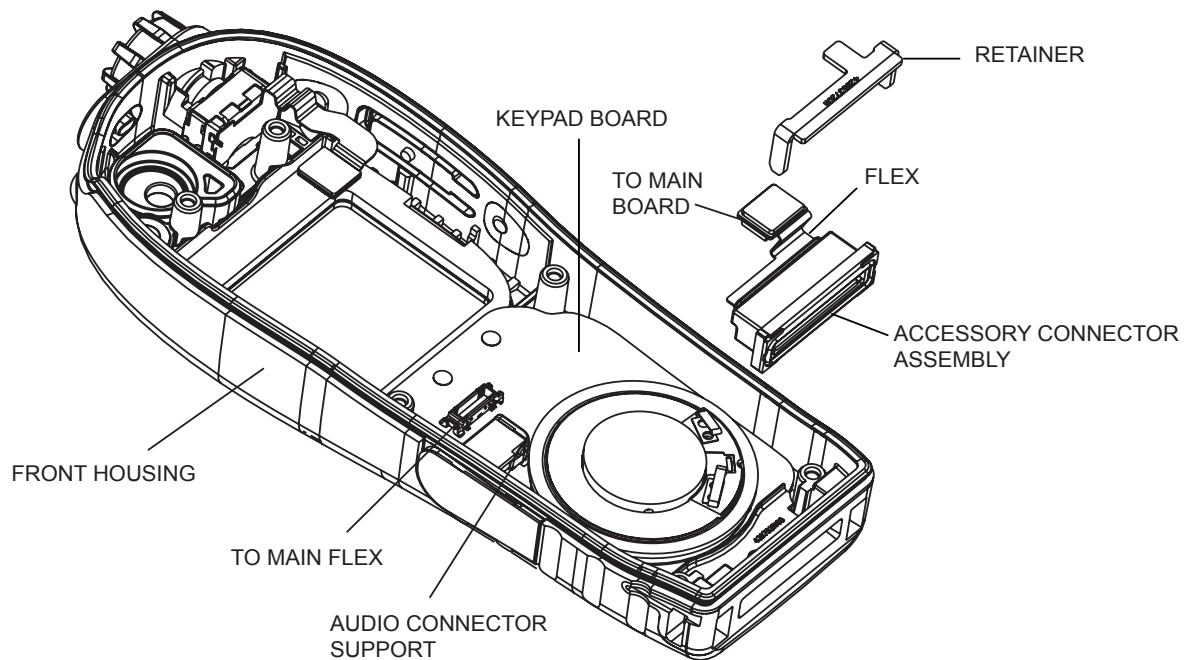
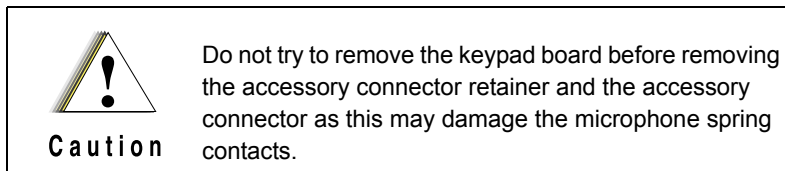

Figure 14 Accessory Connector Removal and Installation

Removing and Installing the Keypad

Recommended tools: no tool is required

To remove the keypad



(See Figure 15)

1. Remove the accessory connector assembly. Refer to "Removing and Installing the Accessory Connector Assembly" on page 18.
2. To remove the support, insert a small flat blade screwdriver between the connector and the support's largest side. The support will slide out.
3. Remove the keypad board from the unit.
4. Remove the keypad.

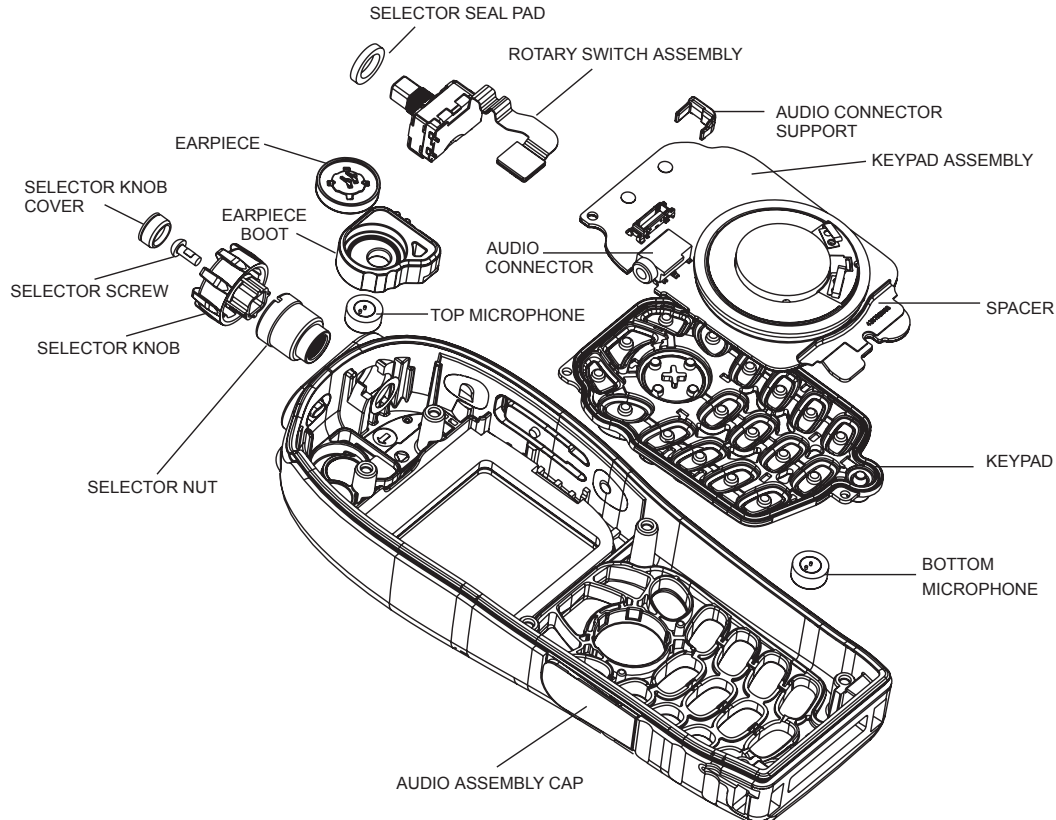
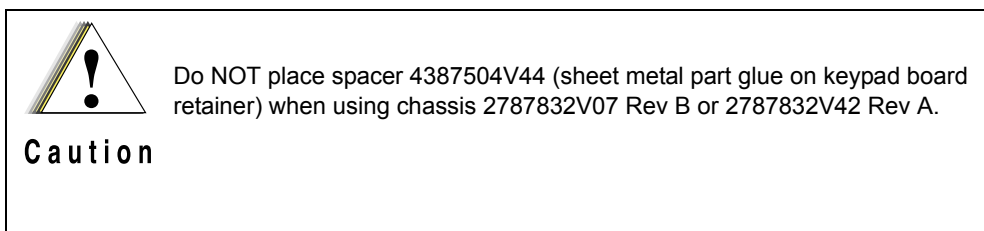

Figure 15 Keypad, Rotary Switch, Microphone, and Earpiece Removal and Installation

To install the keypad

1. Install the keypad. Verify that all the keys are properly inserted into their dedicated holes.
2. Install the keypad board.
3. To install the support, slide it onto the audio connector.
4. Install the accessory connector assembly.



Removing and Installing the Rotary Switch

Recommended tools: T-8 Torx bit, Torx driver, Phillips screwdriver, mini flat-tip screwdriver, nut selector adapter (FR10056AT), hex head screwdriver

To remove the rotary switch

1. Remove the display & chassis assembly. Refer to “Removing and installing the Display” on page 15.
2. Remove the selector knob cover.
3. Unscrew the selector screw.
4. Remove the selector knob.
5. Mount the adapter onto the selector nut. Insert the hex head screwdriver in the adapter and turn counter clockwise to release the selector nut.
6. Remove the rotary switch assembly.

To install the rotary switch

1. Install the rotary switch assembly.
2. Insert the selector nut. Mount the adapter onto the selector nut. Insert the hex head screwdriver in the adapter and turn clockwise to install the selector nut. Screw to 5 ± 0.5 in-lb (0.58 ± 0.058 Nm).
3. Install the selector knob.
4. Install the selector screw. Screw to 2.5 ± 0.3 in-lb (0.28 ± 0.034 Nm).

5. Apply DC 744 RTV white-color adhesive (Motorola part # 1186134U01) to the inner perimeter of the selector knob.
6. Insert the selector knob cover (3687537V02) by using a tiny pin.
7. Use hand tool to push down the selector knob cover. Wipe off excess adhesive using a lint-free cloth. Make sure the selector knob cover is fully pressed.
8. Install the display & chassis assembly.

Removing and Installing the Microphones

Recommended tools: tweezers or narrow blade knife, mini flat-tip screwdriver

To remove the top microphone from the unit

(See Figure 15)

1. Remove the display & chassis assembly. Refer to “Removing and installing the Display” on page 15.
2. To remove the top microphone, press slightly its rubber boot and slightly insert the tweezers or knife inside the boot between the microphone plastic housing and the rubber boot.
3. With an upward motion of the tweezers or knife, remove the microphone. The microphone might be damaged during the removal and should then be replaced by a new one.

To install the top microphone

1. Insert the top microphone into location.
2. Install the display & chassis assembly.

To remove the bottom microphone from the unit

(See Figure 15)

1. Remove the display & chassis assembly. Refer to “Removing and installing the Display” on page 15.

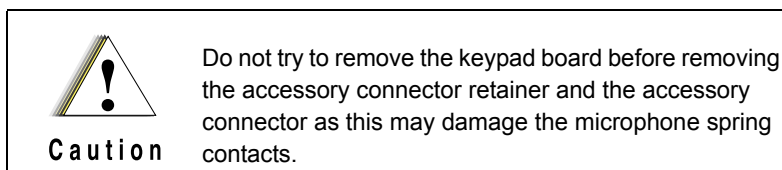

2. Remove the accessory connector assembly. Refer to “Removing and Installing the Accessory Connector Assembly” on page 18.
3. Remove the keypad board and keypad. Refer to “Removing and Installing the Keypad” on page 20.
4. Using tweezers or a mini flat-tip screwdriver, remove the bottom microphone.

To install the bottom microphone

1. Insert the microphone into location.
2. Install the keypad and keypad board.
3. Install the accessory connector assembly.
4. Install the display & chassis assembly.

Removing and Installing the Earpiece

Recommended tools: tweezers

To remove the earpiece from the unit

(See Figure 15)

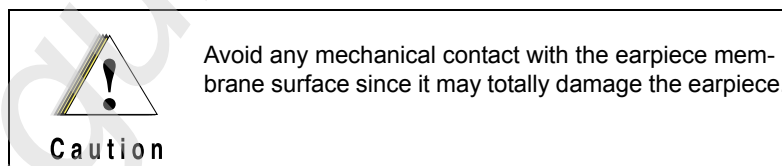

1. Remove the display & chassis assembly. Refer to “Removing and installing the Display” on page 15.
2. Using the tweezers grasp the earpiece green support ring and with an upward motion remove the earpiece.

To install the earpiece

1. Be sure to place the earpiece correctly (evenly) into the rubber boot. Use tweezers for this operation.
2. Gently push the earpiece into the boot until it is firmly inside the boot.
3. Install the display & chassis assembly.

MTH800 Unit - Exploded View

MTH800 components are listed in the table below. The first column marked with a # sign provides you with the call out numbers of the components as marked in Figure 16, Figure 17, and Figure 18.

MTH800 Components List

#	Description	Part/Kit
1.	Thick battery cover with rubber	0188809V59
2.	Slim battery cover with rubber	0188809V58
3.	Long Antenna - 380-430 MHz, or - 430-470 MHz 1	8586381J11 8566504A01
4.	Short Antenna - 380-430 MHz, or - 430-470 MHz 1	8586381J10 8566504A02
5.	Back housing assembly	0188809V42
6.	Rubber cap, blue (2)	4387504V52
7.	Rubber cap, yellow	4387504V51
8.	Rubber cap, green	4387504V53
9.	Logo label	5486278T02
10.	Vehicle adapter internal seal	0187506V59
11.	Tamper evident label	5466516B03
12.	FCC Label	5487503V69
13.	Model label	5487503V70
14.	Vibrator	5916357H01
15.	Washer (6)	0487779V12
16.	Screw (6)	0387839V75
17.	Battery contact seal	3271289L01
18.	Battery lock latch	5587581V07
19.	Vehicle adapter external seal	3287842V20
20.	Antenna switch external seal	3287842V18
21.	Antenna switch internal seal	3287842V05

MTH800 Components List (Continued)

#	Description	Part/Kit
22.	Old Main Board kit - 380-430 MHz, or - 440-470 MHz New Main Board kit - 380-430 MHz, or - 440-470 MHz	PMLE4416_ PMLE4459_ PMLD4359_ PMLE4519_
23.	UCM Screw	0387839V01
24.	UCM Board, or UCM-M Board	CLN8040_ GMLN4561
25.	Chassis assembly	2787832V42
25a.	Poron pad (glued on chassis), not shown	7586477Z01
26.	Main flex assembly	0187506V56
27.	Display board	PMTN4114_
27a.	Spacer (glued on display board), not shown	4387504V34
28.	Display	7287507V03
29.	Display holder	0787502V52
30.	Front housing assembly with lightpipe and insert	0104023J22
31.	Keypad board assembly	PMLN4885_
32.	Accessory connector assembly	0188809V36
33.	Keypad Rubber w/ Felt - w/ Cyrillic characters, or - w/ Latin characters, or - w/ Arabic characters	0104022J27 0102709K86 0102710K62
34.	Rotary switch assembly	0116541H01
35.	Selector knob cover	3687537V02
36.	Selector screw	0387839V01
37.	Selector knob	3687537V05
38.	Selector nut	0287571V04
39.	Earpiece	5086940J02
40.	Earpiece boot	3271288L01
41.	Top microphone	5086346J05
42.	Audio assembly cap	0104023J25
43.	Bottom microphone	5086346J05
44.	Audio connector support	0788394V58
45.	Selector Seal Pad	7587509V86

Torque List

Description	Part/Kit	Quantity	Torque
External screw	0387839V75	6	3.8±0.3 in-lb (0.43±0.034 Nm).
Selector screw	0387839V01	2	2.5±0.3 in-lb (0.28±0.034 Nm)
Selector nut	0287571V04	1	5±0.5 in-lb (0.58±0.058 Nm)
UCM Screw	0387839V01	1	2.5±0.3 in-lb (0.28±0.034 Nm)

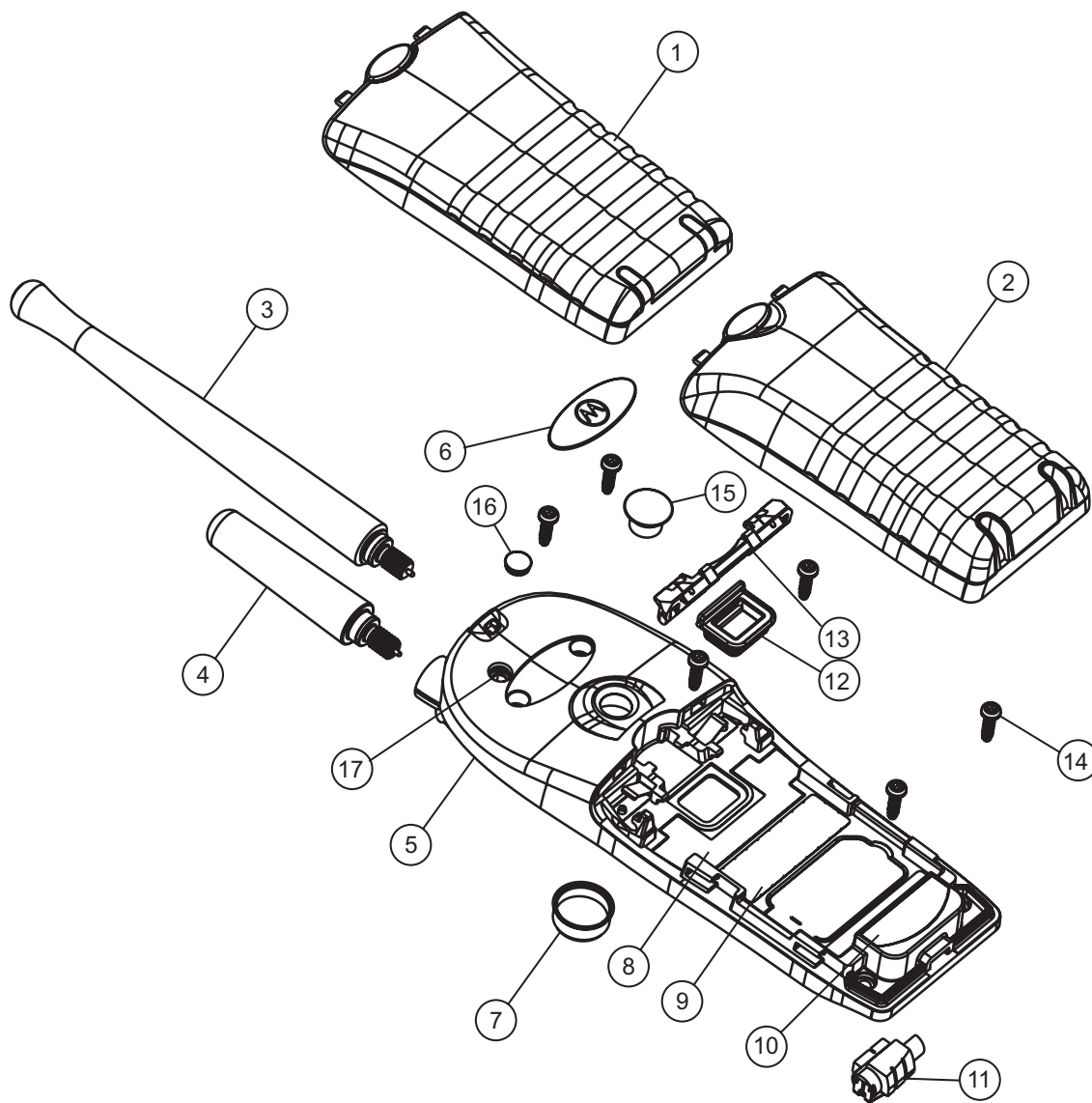

Figure 16 Exploded View - Back Housing

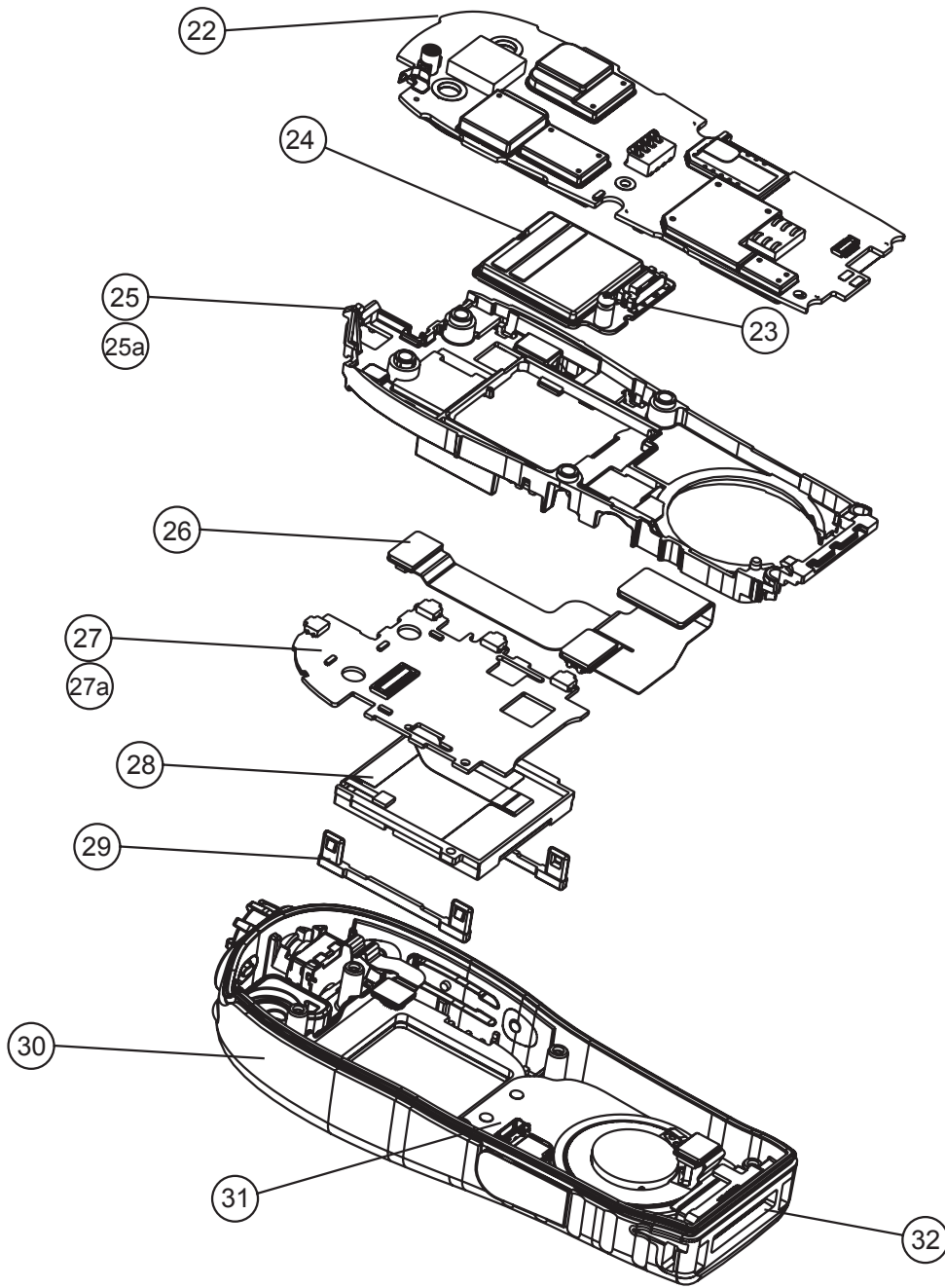

Figure 17 Exploded View (continued) - Display and Chassis Assembly

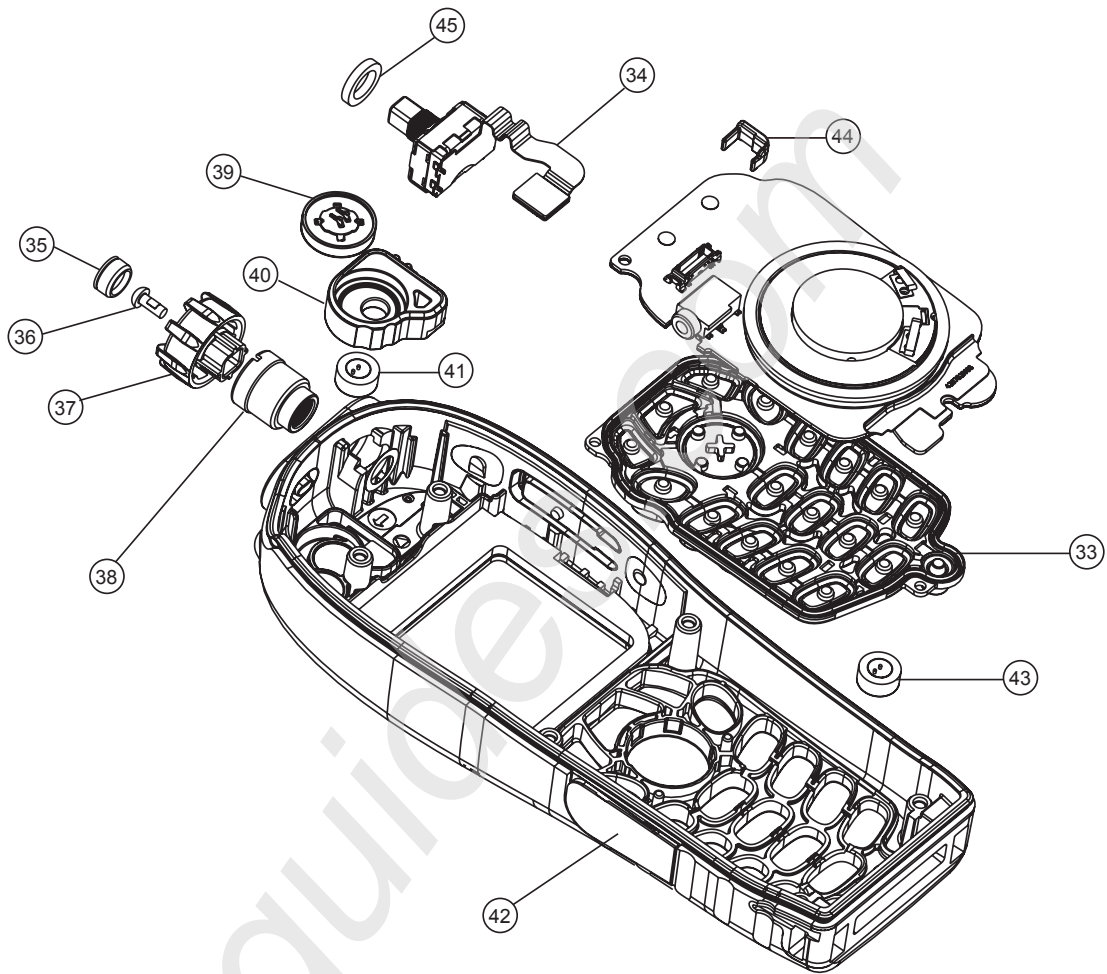

Figure 18 Exploded View (continued) - Front Housing

Replacement Parts

Damaged parts should be replaced with identical replacement parts.
For complete information on ordering required parts and kits, contact your local customer service representative.

Terminal Replacement Parts List

Part/Kit Number	MTH800 Model Description	Quantity
PMLE4416_ PMLE4459_	Main Board kit with <u>old</u> GPS IC - 380-430 MHz, or - 440-470 MHz	1
PMLD4359_ PMLE4519_	Main Board kit with <u>new</u> SiRF GPS IC a) Improved GPS sensitivity b) Requires MR5.6 and above - 380-430 MHz, or - 440-470 MHz	1
PMHN4099_ GMLN4561	UCM kit, or UCM-M kit	1
PMTN4114_	Display board	1
7287507V03	Display	1
0787502V52	Display Holder	2
PMLN4885_	Keypad board	1
0104022J27 0102709K86 0102710K62	Keypad Assembly w/ Felt - Cyrillic, or - Latin, or - Arabic	1
7516278H01 7587835V02 7587835V11	Keypad Rubber - Cyrillic, or - Latin, or - Arabic	1
3587514V11	Speaker Felt	1
0188809V42	Back Housing Assembly	1
8586381J11	Long antenna 380-430MHz	1
8566504A01	Long antenna 430-470MHz	1
8586381J10	Short antenna 380-430MHz	1
8566504A02	Short antenna 430-470MHz	1
0104023J22	Front housing	1

Part/Kit Number	MTH800 Model Description	Quantity
0104023J25	Audio assembly cap	1
0116541H01	Flex, selector assembly	1
7587509V86	Selector Seal Pad	1
0287571V04	Selector nut	1
3687537V05	Selector knob	1
3687537V02	Selector knob cover	1
0387839V01	Selector screw (M2)	1
0387839V01	UCM Screw	1
5086346J05	Microphone	2
5086940J02	Earpiece with support ring	1
3271288L01	Earpiece boot	1
0188809V36	Accessory connector assembly	1
2787832V42	Chassis	1
0187506V56	Flex, Main	1
5916357H01	Vibrator	1
3271289L01	Battery contact seal	1
0187506V59	Vehicle adapter (VA) lock internal seal	1
3287842V20	Vehicle adapter (VA) lock external seal	1
3287842V18	Antenna switch external seal	1
3287842V05	Antenna switch internal seal	1
5487503V70	Label model	1
5487503V69	FCC label	1
5486278T02	Logo label	1
0387839V75	External screw	6
0188809V58	Battery assembly cover, slim (800mAh)	1
1587508V03	Battery cover	1
0188809V59	Battery door assembly, thick (1500mAh)	1
1587508V06	Battery door, thick	1
FTN6308	Digital Car Kit (DCK) cradle for testing an assembled terminal. FTN6308 is not sold separately. It is part of Digital Car Kit FTN6307.	1
3086228J02	RF Cable for cradle, with N-type female output connector, for use with FTN6308. FTN6308 is not sold separately. It is part of Digital Car Kit FTN6307.	1
2888482K04	Cable adapter. Enables testing of a stand-alone main board.	1

Part/Kit Number	MTH800 Model Description	Quantity
FBN7009	Packaging	1 per 20 terminals
0487779V12	Washer	6
4387504V52	Rubber cap, blue	2
4387504V51	Rubber cap, yellow	1
4387504V53	Rubber cap, green	1
7586477Z01	Poron pad (glued on chassis)	1
4387504V34	Spacer (glued on display board)	
0788394V58	Audio connector support	1

Note: PCB No. (380-430 MHz) = 8471339L05
 PCB No. (440-470 MHz) = 8416289H07

Accessories Replacement Parts List

Kit Number	MTH800 Model Description
Batteries	
SNN5705	Standard battery, 800 mAh, Lilon (without battery door)
NNTN4655	Extended battery, 1500 mAh, Lilon (without extended battery door)
0188809V59	1500 mAh battery door
0188809V58	800 mAh battery door
Chargers	
NNTN4250	Travel charger (power supply only)
WALN4092	Rapid travel charger kit including UK and Euro plugs (contains NNTN4250 +SYN7456 +SYN7455)
FTN6306	Dual pocket desktop charger base (requires travel charger WALN4092)
1587845S02	Insert for dual pocket desk top charger
SYN7456	Plug adapter EU for travel charger NNTN4250
SYN7455	Plug adapter UK for travel charger NNTN4250
WPLN4175	Multi-unit Charger 6 pockets with Euro cord
WPLN4176	Multi-unit Charger 6 pockets with UK plug
WPLN4177	Multi-unit Charger 6 pockets with US Plug
RLN5643	Wall mount bracket for multi-unit charger
Vehicular Adapters	
FLN9469	Vehicle power adaptor
FTN6307	Hands-free Digital Car Kit (incl. cradle, junction box, remote speaker mic, PTT)

Kit Number	MTH800 Model Description
GMEA4290	Rooftop Combined GPS/TETRA Antenna Kit, 380-430 MHz. Includes Antenna, Duplex Filter (GMAE4264), DC Adapter Adapter (FTN6790)
GMEA4291	Rooftop Combined GPS/TETRA Antenna Kit, 380-400 MHz. Includes Antenna, Duplex Filter (GMAE4264), DC Adapter (FTN6790)
GMEA4292	Rooftop Combined GPS/TETRA Antenna Kit, 410-430 MHz. Includes Antenna, Duplex Filter (GMAE4264), DC Adapter Adapter (FTN6790)
GMEA4293	Rooftop Combined GPS/TETRA Antenna Kit, 430-470 MHz. Includes Antenna, Duplex Filter (GMAE4264), DC Adapter Adapter (FTN6790)
FTN6790	DC Adapter
GMAE4264	Duplex Filter
Audio accessories	
FTN6596	Rx Only Earpiece for terminal (short coiled cable)
FTN6583	Personal Hands Free (PHF) kit with PTT
FTN6595	Mini lapel microphone kit (3 Wire kit, long cable, compatible with earshells and voicetubes)
FTN6707	2-wire Surveillance Kit - Earpiece with combined microphone and Push-To-Talk
PMLN4605	Transparent acoustic tube with rubber eartip for FTN6707
WADN4223	Earshell - large
WADN4224	Earshell - small
FTN6582	Breeze headset with boom mic and in-line PTT
NTN8370	Acoustic Voicetube with foam plug for extreme noise environments
NTN8371	Acoustic Voicetube with rubber ear tips for low noise environments
RMN5042	Remote Speaker Microphone
RLN4939	Rx Only for Remote Speaker Microphone
GMMN1105	Audio Bundle Kit (contains FTN6596, WADN4224, WADN4223, NTN8370, NTN8371 and black nylon bag)
Carrying Accessories	
RLN4892	Hard leather case with swivel 2.5" belt loop
RLN4891	Soft leather carry case with swivel 2.5" belt loop
HLN9767	Wrist strap
FTN6355	Shoulder wearing device with stud
FTN6302	Bracket with U-slot (for use with belt clip)
HLN9714	Belt clip (long - 2.5"). For use with above bracket with U slot
HLN9844	Belt clip (short - 1.5"). For use with above bracket with U slot
Antennas	
8586381J11	Long coaxial antenna for 380-430 MHz combined GPS / TETRA
8586381J10	Short helical antenna for 380-430 MHz combined GPS / TETRA
8566504A01	Long antenna for 430-470 MHz 1

Kit Number	MTH800 Model Description
8566504A02	Short antenna for 430-470 MHz 1
Data	
PMKN4025A	RS-232 Data cable - for connecting the MTH800 to an external device (such as a laptop or desktop PC). The MTH800 will then be capable of transmitting and receiving data from the external device.
FLN9636	RS-232 Programming cable (set cable switch to FLASH)
PMKN4026A	USB Cable
Others	
2888482K04	Cable adapter. Enables testing of a stand-alone main board.
3086228J02	RF Cable for cradle, with N-type female output connector, for use with FTN6308. FTN6308 is not sold separately. It is part of Digital Car Kit FTN6307.
FTN6308	Digital Car Kit (DCK) cradle for testing an assembled terminal. FTN6308 is not sold separately. It is part of Digital Car Kit FTN6307.

Notes

APPENDIX A

SERVICE INFORMATION

Replacement Parts

Damaged parts should be replaced with identical replacement parts. For complete information on ordering required parts and kits, contact your local customer service representative.

Level 3 Maintenance

All Terminal Support Depots are level 3 service partners. The depots are capable of performing repairs down to component level where retuning is required. Contact your local CGISS office for information. For details, please refer to Service Information below.

Service Information

European Radio Support Centre (ERSC)

Motorola European Radio Support Centre is available at:

Motorola European Radio Support Centre ERSC
Tel.: +49 (0)30 6686 1555
Fax: +49 (0)30 6686 1579
Am Borsigturm 130
13507 Berlin
Germany

The ERSC Customer Information Desk is available through the following Service Numbers:

Austria: 06 60 75 41

Italy: 16 78 77 387

Belgium: 08 00 72 471

Luxembourg: 08 00 23 27

Denmark: 80 01 55 72

Netherlands: 60 22 45 13

Finland: 08 00 11 49 10	Norway: 80 01 11 15
France: 05 90 30 90	Portugal: 05 05 49 35 70
Germany: 01 30 18 75 24	Spain: 90 09 84 902
Greece: 00 80 04 91 29 020	Sweden: 02 07 94 307
UK: 08 00 96 90 95	Switzerland: 1 55 30 82
Ireland: 18 00 55 50 21	Iceland: 80 08 147

Please use these numbers for Repair Enquiries only.

EMEA Systems Support Centre (ESSC)

The Systems Support Centre is available at:

Telephone:	+44 (0) 1256 484448
E-mail:	ESSC@motorola.com

European Systems Component Centre (ESCC)

The Systems Component Centre is available at:

Telephone:	+49 (0) 30 66861414
Telefax:	+49 (0) 30 66861426
E-mail:	ESCC@motorola.com

Parts Identification and Ordering

Request for help in identification of non-referenced spare parts should be directed to the Customer Care Organization of Motorola's local area representation. Orders for replacement parts, kits and assemblies should be placed directly on Motorola's local distribution organization or via the Extranet site Motorola Online at <https://emeaonline.motorola.com>

EMEA Test Equipment Support

Information related to support and service of Motorola Test Equipment is available by calling the Motorola Test Equipment Service in Germany at +49 (0) 6128 702179, Telefax +49 (0) 6128 951046, through the Customer Care Organization of Motorola's local area representation, or via the Internet at <http://www.gd-decisionssystem.com/cte>

Asia, Pacific Region

Technical Support

Technical support is available to assist the dealer/distributor in resolving any malfunction which may be encountered. Initial contact should be by telephone wherever possible. When contacting Motorola Technical Support, be prepared to provide the product **model number** and the unit's **serial number**.

Further Assistance From Motorola

You can also contact the Customer Help Desk through the following web address:

<http://www.motorola.com/governmentandenterprise>

Piece Parts

Some replacement parts, spare parts, and/or product information can be ordered directly. If a complete Motorola part number is assigned to the part, it is available from Motorola Radio Aftermarket and Accessory Division (AAD). If no part number is assigned, the part is not normally available from Motorola. If a parts list is not included, this generally means that no user-serviceable parts are available for that kit or assembly.

Note on this digital Tetra Terminal: **The CPS has no capability to tune the terminal. Tuning the terminal can only be performed at the factory or at the appropriate Motorola Service Center. Components replacement can affect the terminal tuning and must only be performed by the appropriate Motorola Service Center.**

All orders for parts/information should include the complete Motorola identification number. All part orders should be directed to your local AAD office. Please refer to your latest price pages.

Latin America Region

Latin America Radio Support Centres

The Customer Support is available through the following service centres:

Warranty and Repairs:**MOTOROLA DE COLOMBIA SERVICE CENTRE**

Carrera 7 No. 71-52

Torre B piso 13

Oficina 1301

Bogota- Colombia

(571) 376-6990

MOTOROLA DE MEXICO SERVICE CENTRE

Bosques de Alisos #125

Col. Bosques de las Lomas

CP 05120 Mexico DF

5252576700

Piece Parts:

To order parts in Latin America and the Caribbean contact your local Motorola CGISS representative.

MOTOROLA, INC.

Latin American Countries Region

789 International Parkway

Sunrise, FL 33325

USA

954-723-8959

MOTOROLA DE ARGENTINA

Ave. del Libertador 1855

B1638BGE, Vicente Lopez

Buenos Aires, Argentina

5411-4317-5300

MOTOROLA DE LOS ANDES C.A.

Ave. Francisco de Miranda

Centro Lido, Torre A

Piso 15, El Rosal

Caracas, 1060 Venezuela

58212-901-4600

MOTOROLA DO BRASIL LTDA.

Rua Paes Leme, 524, 13 Andar

05424-010 São Paulo, Brasil

5511-3030-5000

MOTOROLA CHILE
Ave. Nueva Tajamar 481
Edif. World Trade Center
Of. 1702, Torre Norte
Las Condes
Santiago, Chile
562-338-9000

MOTOROLA DE COLOMBIA, LTDA.
Carrera 7 #71-52
Torre A, Oficina 1301
Bogotá, Colombia
571-376-6990

MOTOROLA DE COSTA RICA
Oficentro Plaza Mayor
Piso 3, Rohmoser
San José, Costa Rica
506-296-5385

MOTOROLA DEL ECUADOR
Nuñez de Balboa #OE1-245
y Pedro Alfaro, Villa Flora
Quito, Ecuador
593-2264-1627

MOTOROLA DE MEXICO, S.A.
Calle Bosques de Alisos #125
Col. Bosques de Las Lomas
05120 México D.F.
México
52-555-257-6700

MOTOROLA DEL PERU, S.A.
Ave. República de Panama 3535
Piso 11, San Isidro
Lima 27, Peru
511-211-0700

Technical Support:

<https://businessonline.motorola.com>, go to Contact Us to request technical support

Some replacement parts, spare parts, and/or product information can be ordered directly. If a complete Motorola part number is assigned to the part, it is available from Motorola. If no part number is assigned, the part is not normally available from Motorola. If the part number is appended with an asterisk, the part is serviceable by Motorola Depot only. If a parts list is not included, this generally means that no user-serviceable parts are available for that kit or assembly.

Recommended Programming Equipment

Name	Part Number
MTH800 CPS	For actual P/N contact your support centre
RS-232 Programming cable (set cable switch to FLASH)	FLN9636
USB Programming cable	PMKN4026_

Service Replacement Kit Matrix

Sales Model	Description	Service Tanapa	Description
MTH800 380-430 MHz		PMUE2556BS	S/T MTH800 UHF CLEAR
		PMUE2688BS	S/T MTH800 UHF TEA1
		PMUE2689BS	S/T MTH800 UHF TEA2
		PMUE2761BS	S/T MTH800 UHF TEA3 *
		PMUE2690BS	S/T MTH800 W/UCM
		PMUE2691BS	S/T MTH800 TEA1 W/UCM
		PMUE2692BS	S/T MTH800 TEA2 W/UCM
		PMUE2762BS	S/T MTH800 UHF TEA3 W/UCM AES128 *
		PMUE2693BS	S/T MTH800 CLEAR ARABIC
		PMUE2694BS	S/T MTH800 W/UCM ARABIC
		PMUE2695BS	S/T MTH800 TEA1 ARABIC
		PMUE2696BS	S/T MTH800 TEA1 W/UCM ARABIC
		PMUE2763BS	S/T MTH800 UHF ARABIC TEA3 *
		PMUE2764BS	S/T MTH800 UHF TEA3 W/UCM ARABIC AES128 *
		PMUE2765BS	S/T MTH800 UHF CYRILLIC TEA3 *
		PMUE2766BS	S/T MTH800 UHF TEA3 W/UCM CYR AES128 *
	PMUE2697BS	S/T MTH800 380MHz TEA2 w/o UCM w/A	
MTH800 440-470 MHz		PMUE2833BS	S/T MTH800 440M CLEAR
		PMUE2832BS	S/T MTH800 440M W/UCM AES128
		PMUE2834BS	S/T MTH800 440M TEA1
		PMUE2835BS	S/T MTH800 440M W/UCM TEA1 AES128
		PMUE2836BS	S/T MTH800 440M TEA2
		PMUE2837BS	S/T MTH800 440M W/UCM TEA2 AES128
		PMUE2838BS	S/T MTH800 440M CLEAR CYR
		PMUE2839BS	S/T MTH800 440M W/UCM AES128 CYR
		PMUE2840BS	S/T MTH800 440M TEA1 CYR
		PMUE2841BS	S/T MTH800 440 +UCM TEA1 AES128 CYR
		PMUE2842BS	S/T MTH800 440M TEA3*
		PMUE2843BS	S/T MTH800 440M W/UCM TEA3 AES128*
		PMUE2844BS	S/T MTH800 440M CYR TEA3*
	PMUE2845BS	S/T MTH800 440M W/UCM AES128 CYR TEA3*	

Note: All models listed in the Service Tanapa Column are not field replaceable for Latin America.

* TEA3 functionality is only available from MR5.4 or later.

APPENDIX B CONNECTOR PIN FUNCTIONS

CE Bottom Connector

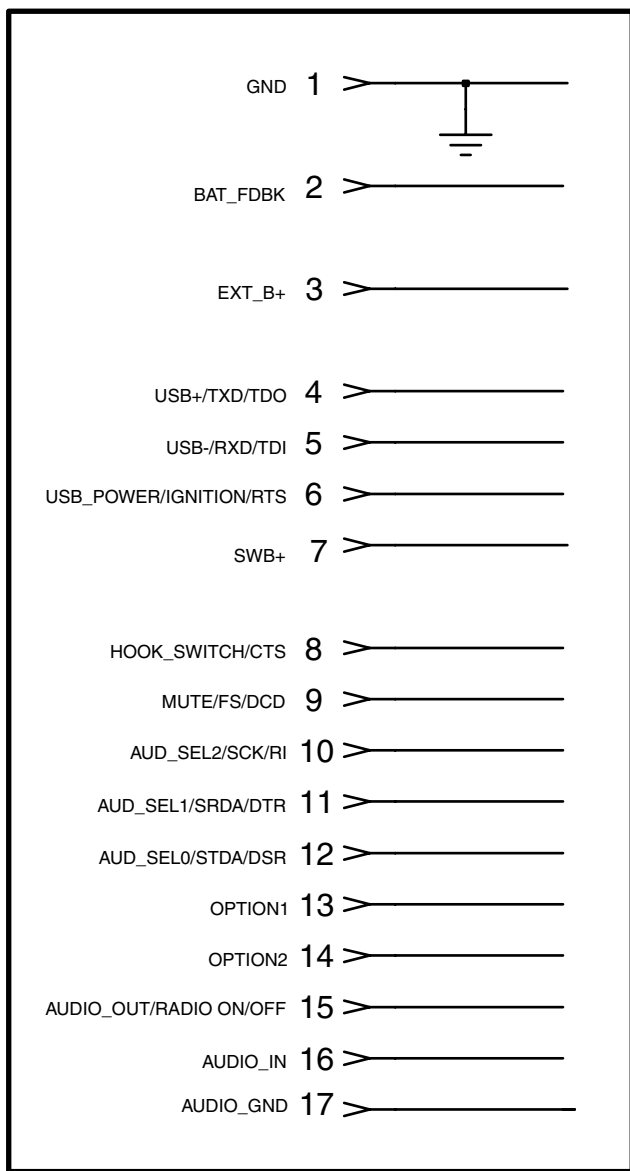

17 pin CE Connector

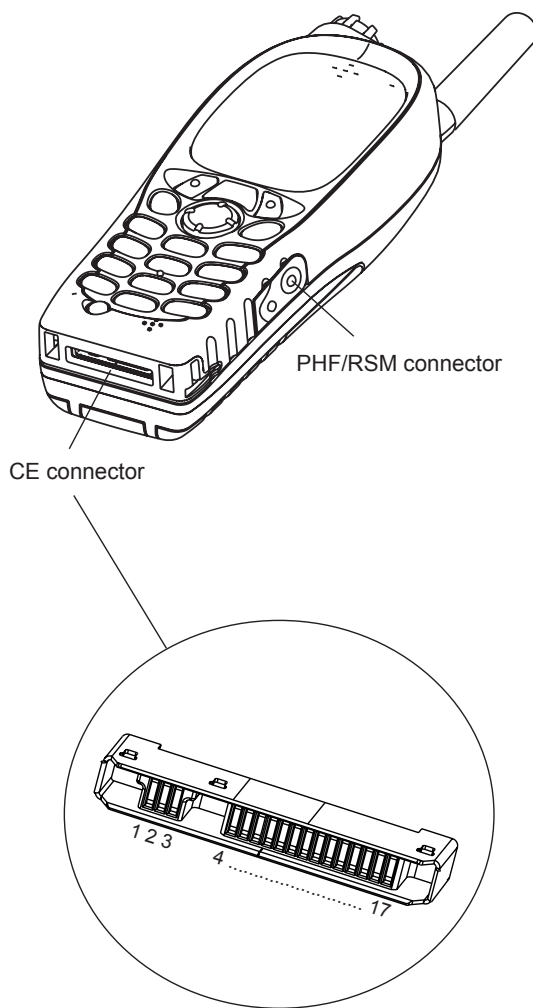

Mode Select (Option1 and Option2):

The following logic levels can be used to select the requested CE Bus mode:

MODE	OPTION_1	OPTION_2	USB_PWR	AUDIO_IN
NORMAL (no accessory)	1	1	0	X
USB Accessory/Computer	1	1	>4.0V	1
USB accessory / RS232 (6 wire)	1	1	>4.0V	0
Dumb Accessory	1	0	X	1
USB OTG	1	0	X	0
RS-232 (8 wire)/IDB Smart Cable	0	1	X	1
Bluetooth (RS-232 (4 wire) / SSI)	0	1	X	0
PTT	0	0	X	X
SB9600	 Diode connected from Option 2 to 1		X	X

Accessory Connector Pin-Outs

Pin No.	Signal Name (Short Form)	Power/ Default States	USB	USB OTG	Bluetooth (RS232/ SSI)	RS232 (8 wire)	USB/ RS232 (6 wire)	JTAG
1	Power Ground (GND)	GND	GND	GND	GND	GND	GND	GND
2	Battery Feedback (BATT_FDBK)	BATT_FDBK ⁻	BATT_FDBK ⁻	BATT_FDBK ⁻	BATT_FDBK ⁻	BATT_FDBK ⁻	RTS	BATT_FDBK ⁻
3	External Power (EXTB+)	EXTB+	EXTB+	EXTB+	EXTB+	EXTB+	EXTB+	EXTB+
4	USB+/TXD (D+)		D+	D+	TXD	TXD	D+	TDO
5	USB-/RXD (D-)		D-	D-	RXD	RXD	D-	TDI
6	USB Power/Ignition/Send/End / RTS (USB_PWR)		USB_PWR ⁻	USB_PWR ⁻	RTS	RTS	USB_PWR ⁻	RESET_IN
7	Switched Battery (SWB+)	SWB+	SWB+	SWB+	SWB+	SWB+	SWB+	SWB+
8	Hook Switch / FM_DATA / CTS (HKSW)		HKSW		CTS	CTS	CTS	Mcu_DE
9	MUTE/FS/DCD (MUTE)				FS	DCD	DCD	Dsp_DE
10	DUMB_SEL2/SCK/RI (DSEL2)	DSCEN	DSCEN		SCK	RI	TXD	TCK
11	DUMB_SEL1 / FM_CLOCK /SRDA / DTR (DSEL1)			CABLE_ID	SRDA	DTR	DTR	TMS
12	DUMB_SEL0 / FM_EN / STDA/ DSR (DSEL0)			DONGLE	STDA	DSR	RXD	TRST
13	Option 1 (OPT1)	UPLink	UPLink		OPT1	OPT1	OPT1	OPT1
14	Option 2 (OPT2)	DNLink	DNLink		OPT2	OPT2	OPT2	OPT2
15	Audio Out On/Off (AUDIO_OUT)	AUDIO_OUT	AUDIO_OUT	AUDIO_OUT	AUDIO_OUT	AUDIO_OUT	AUDIO_OUT	AUDIO_OUT
16	Audio In (AUDIO_IN)	AUDIO_IN	AUDIO_IN	AUDIO_IN	AUDIO_IN	AUDIO_IN	AUDIO_IN	AUDIO_IN
17	Audio Ground (AUDIO_GND)	AUDIO_GND	AUDIO_GND	AUDIO_GND	AUDIO_GND	AUDIO_GND	AUDIO_GND	AUDIO_GND

Note: For additional information refer to the detailed service manual chapter: Theory of Operation.

AUDIO Side Connector

PHF/RSM Connector

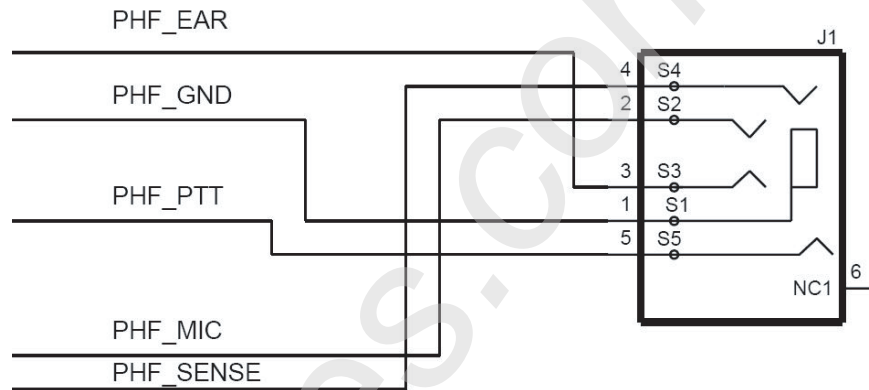

PHF/RSM Plug

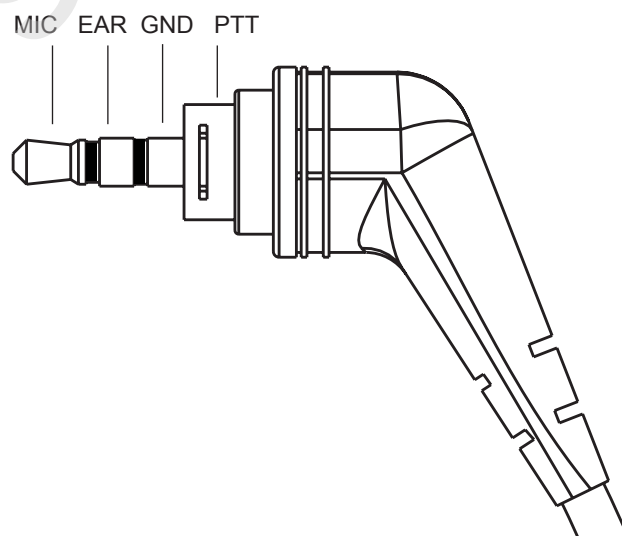

RSM Modes of Operation

MODE	OPTION SELECT 1 (PIN #13)	OPTION SELECT 2 (PIN #14)	AUDIO IN (PIN #16)	DUMB SEL 0 (PIN #12)	DUMB SEL 2 (PIN #10)	MUTE (PIN #9) TERMIAL OUTPUT
ACCESSORY ATTACHED (SPEAKER AND MICROPHONE ARE OFF)	1	0	1	0	0	0
PTT SIMPLEX (SPEAKER IS OFF MICROPHONE IS ACTIVE, TERMINAL IS IN SIMPLEX MODE)	0	0	1	0	0	0
PTT TIC (SPEAKER IS SWITCHED OFF, MICROPHONE IS ACTIVE, TERMINAL IS IN TELEPHONE INTERCONNECT MODE)	0	0	1	0	0	1
EMERGENCY SW (SPEAKER IS OFF MICROPHONE COULD BE ON OR OFF)	0	0	0	0	0	0
SPEAKER OFF (MICROPHONE COULD BE ON OR OFF)	X	0	X	0	0	0
SPEAKER ON (MICROPHONE OFF)	1	0	1	0	0	1

Note: For additional information refer to the detailed service manual chapter: Theory of Operation.